

Steelmax

Model S14

14" Dry Metal Cutting Saw



OPERATOR'S MANUAL

 **WARNING!**

TO REDUCE THE RISK OF INJURY, USER MUST READ AND UNDERSTAND INSTRUCTION MANUAL.



EYE PROTECTION
REQUIRED



HEARING PROTECTION
REQUIRED



NEVER PLACE
FINGERS NEAR
CUTTING AREA.
BEWARE OF
ROTATING
MACHINE PARTS

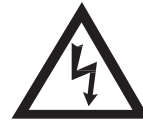

LINE VOLTAGE
PRESENT



MODEL S14 (120 or 230V) (50 or 60 Hz single phase)

Serial # _____

Date of Purchase _____

14” Dry Metal Cutting Saw

Congratulations on your purchase of a Steelmax brand Dry Metal Cutting Saw. Please complete and mail your product registration card. Doing so will validate your machine’s warranty period and ensure prompt service if needed. We sincerely thank you for selecting a product from Steelmax.

TABLE OF CONTENTS

Limited Warranty	2
General Safety Rules and Specific Instructions	3-4
Specific Safety Rules and Symbols	5-7
Functional Drawings	8
Exploded View	9
Parts List	10
Assembly View	11
Operation	12-13
Emptying the Chip Chamber	13
Maintenance / Changing Saw Blades	14
Troubleshooting Checklist	15
Specifications	16
Accessories	16
Warranty Card	17-18

LIMITED WARRANTY

Steelmax Tools LLC (STEELMAX) will, within twelve (12) months from the original date of purchase, repair or replace any goods found to be defective in materials or workmanship, provided the product warranty registration card has been returned to STEELMAX within thirty (30) days of purchase date (proof of purchase required). This warranty is void if tool is used on materials thicker than those specified under normal use, has been damaged by accident, neglect, improper service, or other causes not arising out of defects in materials or workmanship. This warranty does not apply to machines and/or components which have been altered, changed, or modified in anyway, or subjected to use beyond recommended capacities and specifications. Electrical components are subject to respective manufacturers’ warranties. All goods returned defective shall be returned prepaid freight to STEELMAX, which shall be the buyer’s sole and exclusive remedy for defective goods. In no event shall STEELMAX be liable for loss or damage resulting directly or indirectly from the use of merchandise or from any other cause. STEELMAX is not liable for any costs incurred on such goods or consequential damages. No officer, employee or agent of STEELMAX is authorized to make oral representations of fitness or to waive any of the foregoing terms of sale and none shall be binding on STEELMAX.

STEELMAX RESERVES THE RIGHT TO MAKE
IMPROVEMENTS AND MODIFICATIONS TO DESIGN WITHOUT PRIOR NOTICE.

STEELMAX TOOLS LLC

GENERAL SAFETY RULES

WARNING! Read and Understand all Instructions.

Failure to follow all instructions listed below, may result in electric shock, fire and/or serious personal injury.

SAVE THESE INSTRUCTIONS

Work Area

- Keep Your Work Area Clean and Well Lit.
- Cluttered benches and dark areas invite accidents.
- Do not operate power tools in explosive atmospheres, such as in the presence of flammable liquids, gases, or dust. Power tools create sparks which may ignite the dust or fumes.
- Keep bystanders, children, and visitors away while operating a power tool. Distractions can cause you to lose control.

Electrical Safety

- Grounded tools must be plugged into an outlet properly installed and grounded in accordance with all codes and ordinances. Never remove the grounding prong or modify the plug in any way. Do not use any adapter plugs. Check with a qualified electrician if you are in doubt as to whether the outlet is properly grounded. If the tools should electrically malfunction or break down, grounding provides a low resistance path to carry electricity away from the user.
- Avoid body contact with grounded surfaces such as pipes, radiators, ranges and refrigerators. There is an increased risk of electric shock if your body is grounded.
- Don't expose power tools to rain or wet conditions. Water entering a power tool will increase the risk of electric shock.

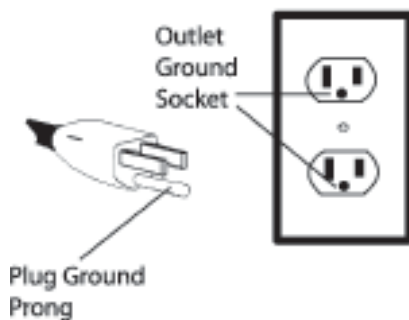

- Do not abuse the cord. Never use the cord to carry the tools or pull the plug from an outlet. Keep cord away from heat, oil, sharp edges or moving parts. Replace damaged cords immediately. Damaged cords increase the risk of electric shock.

- When operating a power tool outside, use an outdoor extension cord marked "W-A" or "W." These cords are rated for outdoor use and reduce the risk of electric shock.

(Note) When using an extension cord, be sure to use one heavy enough to carry the current your product will draw. An undersized cord will cause a drop in line voltage resulting in loss of power and overheating. **The recommended minimum is a 12 gauge extension cord not exceeding 50 feet.**

GENERAL SAFETY RULES (continued)

Personal Safety

- Stay alert, watch what you are doing and use common sense when operating a power tool. Do not use tool while tired or under the influence of drugs, alcohol, or medication. A moment of inattention while operating power tools may result in serious personal injury.
- Dress properly. Do not wear loose clothing or jewelry. Contain long hair. Keep your hair, clothing, and gloves away from moving parts. Loose clothes, jewelry, or long hair can be caught in moving parts.
- Avoid accidental starting. Be sure switch is off before plugging in. Carrying tools with your finger on the switch or plugging in tools that have the switch on invites accidents.
- Remove adjusting keys or switches before turning the tool on or plugging it in. A wrench or a key that is left attached to a rotating part of the tool may result in personal injury.
- Do not overreach. Keep proper footing and balance at all times. Proper footing and balance enables better control of the tool in unexpected situations.
- Use safety equipment. Always wear eye protection. Always wear hearing protection. Dust mask, non-skid safety shoes, hard hat, or hearing protection must be used for appropriate conditions.

Tool Use and Care

- Use machine vise to secure and support the workpiece. Drop piece or long material profiles must be supported. Holding the work by hand is unstable and may lead to loss of control. Always use machine vise.
- Do not force tool. Use the correct tool for your application. The correct tool will do the job better and safer at the rate for which it is designed.
- Do not use tool if switch does not turn it on or off. Any tool that cannot be controlled with the switch is dangerous and must be repaired.
- Disconnect the plug from the power source before making any adjustments, changing accessories, or storing the tool. Such preventive safety measures reduce the risk of starting the tool accidentally.
- Store idle tools out of reach of children and other untrained persons. Tools are dangerous in the hands of untrained users.
- Maintain tools with care. Keep cutting tools sharp and clean. Properly maintained tools, with sharp cutting edges are less likely to bind and are easier to control.
- Check for misalignment or binding of moving parts, breakage of parts, and any other condition that may affect the tools operation. If damaged, have the tool serviced before using. Many accidents are caused by poorly maintained tools.
- Use only accessories that are recommended by the manufacturer for your model. Accessories that may be suitable for one tool, may become hazardous when used on another tool.

SERVICE

- Tool service must be performed only by qualified repair personnel. Service or maintenance performed by unqualified personnel could result in a risk of injury.
- When servicing a tool, use only identical replacement parts. Follow instructions in the Maintenance section of this manual. Use of unauthorized parts or failure to follow Maintenance Instructions may create a risk of electric shock or injury.

SPECIFIC SAFETY RULES AND SYMBOLS



WARNING!

DO NOT OPERATE MACHINE IF WARNING AND/OR INSTRUCTION LABELS ARE MISSING OR DAMAGED.
CONTACT STEELMAX FOR REPLACEMENT LABELS.

14 inch Metal Cutter			
Model 514 www.steelmax.com			
RPM	1450	Amps	15
Blade Arbor	1"	Voltage	120 VAC (250 V for)
Maximum Depth of cut 4.75" @ 90°			
Maximum Solid Mild Steel Cutting Capacity 1"			
Serial #	Date of Manufacture		

WARNING: To reduce the risk of injury, user must read and understand manufacturer manual. USE ONLY STEELMAX APPROVED REPLACEMENT SAW BLADES!			
	CARBIDE-TIPPED	CERMET-TIPPED	
MILD STEEL	SM-BLL-14	SM-BLL-CT-14-MS	
THIN MILD STEEL	SM-BLL-14-TS		
ALUMINUM	SM-BLL-14-A		
STAINLESS STEEL	SM-BLL-14-SS	SM-BLL-CT-14-SS	

WARNING:
KEEP HANDS OUT OF THE PATH OF SAW BLADE!
ALWAYS WEAR EYE AND HEARING PROTECTION DURING OPERATION!



WARNING:
FOR YOUR OWN SAFETY READ INSTRUCTION MANUAL BEFORE OPERATING SAW

1. ALWAYS WEAR EYE PROTECTION
2. KEEP HANDS OUT OF PATH OF SAW BLADE.
3. DO NOT OPERATE SAW WITHOUT GUARD IN PLACE.
4. DO NOT PERFORM ANY OPERATION FREEHAND.
5. NEVER REACH AROUND SAW BLADE.
6. TURN OFF TOOL AND WAIT FOR SAW BLADE TO STOP BEFORE MOVING WORKPIECE OR CHANGING SETTINGS.
7. DISCONNECT POWER BY UNPLUGGING TOOL BEFORE CHANGING BLADE OR SERVICING.
8. DO NOT WEAR NECKTIES, JEWELRY OR LOOSE CLOTHING.
9. USE ONLY STEELMAX 14" CARBIDE AND CERMET-TIPPED METAL CUTTING SAW BLADES RATED AT A MINIMUM OF 1400 RPM.

WARNING:
RETURN THIS GUARD TO ITS ORIGINAL POSITION AND SECURE IT IN PLACE AFTER CHANGING BLADE

KEEP HANDS AND BODY AWAY FROM AND TO THE SIDE OF BLADE. CONTACT WITH BLADE WILL RESULT IN SERIOUS INJURY! Use only authorized replacement blades!

WARNING:
To reduce the risk of injury, check lower guard. It must close instantly! Support and clamp work. Wear eye and hearing protection.

WARNING:
Drop piece may pose an ejection hazard! Use extra caution when cutting thin slices.

ALWAYS WEAR EYE AND HEARING PROTECTION



Eye PROTECTION REQUIRED



Hearing PROTECTION REQUIRED



NEVER PLACE FINGERS NEAR CUTTING AREA



LINE VOLTAGE PRESENT

Symbol	Description
V.....	volts
A.....	amperes
HZ.....	hertz
min.....	minutes
~.....	alternating current
no.....	no load speed

1. Only use Steelmax brand approved saw blades. Unauthorized blades may be dangerous!
2. Keep saw blades securely fastened. Check blade flanges for debris before installing any new blade.
3. Do not use dull or broken blades. Check blades often for condition and wear.
4. Check blade cover for proper fit to minimize the risk of flying debris.
5. Beware of ejecting chips. They become HOT both during and after cutting.
6. Always make provisions for safe handling of excess material.
7. Keep saw base free from dirt and other debris.
8. Beware of ejecting drop piece. Thinner slices pose a significant ejection hazard.

To obtain an additional copy of your manual please contact Steelmax at:

Ph. 303-690-9146

Fx. 303-690-9172

www.steelmax.com

SPECIFIC SAFETY RULES (continued)

- **DANGER!** — Keep hands and body away from and to the side of the blade. Contact with blade will result in serious injury.

- **WARNING!** — To reduce the risk of injury, check lower guard. It must close instantly! Keep free hand away from blade at all times during operation. Support and clamp work. Wear eye and hearing protection.

Additional Specific Safety Rules:

DANGER! Keep hands away from cutting area and blade. Keep your second hand on auxiliary handle, or motor housing. If both hands are holding the saw, they cannot be cut by the blade.

·Keep your body positioned to either side of the saw blade, but not in line with the saw blade. KICKBACK could cause the material to jump backwards. (See "Causes and Operator Prevention of Kickback.")

·Do not reach underneath the work. The guard can not protect you from the blade below the work.

·Check lower guard for proper closing before each use. Do not operate saw if lower guard does not move freely and close instantly. Never clamp or tie the lower guard into the open position. If saw is accidentally dropped, lower guard may be bent. Raise the lower guard and make sure it moves freely and does not touch the blade or any other part, at all angles and depths of cut.

·Check the operation and condition of the lower guard spring. If the guard and the spring are not operating properly, they must be serviced before use. Lower guard may operate sluggishly due to damaged parts, gummy deposits, or a buildup of debris.

·An unprotected, coasting blade will cause the saw to cut whatever is in its path. Be aware of the time it takes for the blade to stop after switch is released.

·NEVER hold piece being cut in your hands. It is important to support the work properly to minimize body exposure, blade binding, or loss of control.

·Contact with a "live" wire will also make exposed metal parts of the tool "live" and shock the operator.

·Always use blades with correct size and shape arbor holes. Blades that do not match the mounting hardware of the saw will run eccentrically, causing loss of control.

·Never use damaged or incorrect blade washer or bolts. The blade washer and bolt were specially designed for your saw, for optimum performance and safety of operation.

·Always clamp workpiece in vise and check security of vise bolts and position often. Vise can loosen due to vibration.

SPECIFIC SAFETY RULES (continued)

CAUSES AND OPERATOR PREVENTION OF KICKBACK

Kickback is a sudden reaction to a pinched, bound or misaligned saw blade, causing an uncontrolled workpiece to lift up and out of the saw toward the operator. When the blade is pinched or bound tightly by the kerf (saw cut) closing down, the blade stalls and the motor reaction drives the workpiece rapidly backward. If the blade becomes twisted or misaligned in the cut, the teeth at the back edge of the blade can dig into the top surface of the material causing the material to climb out of the blade and jump back toward operator. Kickback is the result of tool misuse and/or incorrect operating procedures or conditions and can be avoided by taking proper precautions as given below:

Maintain a firm grip with both hands on the saw. KICKBACK forces can be controlled by the operator, if proper precautions are taken.

When blade is binding, or when interrupting a cut for any reason, release the trigger and hold the saw motionless in the material until the blade comes to a complete stop. Never attempt to remove the workpiece from the saw or pull the material backward while the blade is in motion or KICKBACK may occur. Investigate and take corrective actions to eliminate the cause of blade binding.

When restarting a saw in the workpiece, center the saw blade in the kerf and check that saw teeth are not engaged into the material. If saw blade is binding, it may walk up or KICKBACK from the workpiece as the saw is restarted.

Support large panels to minimize the risk of blade pinching and KICKBACK. Large panels tend to sag under their own weight. Supports must be placed under the panel on both sides, near the line of cut and near the edge of the panel.

Do not use dull or damaged blade. Dull or improperly set blades produce narrow kerf causing excessive friction, blade binding and KICKBACK.

Blade depth and miter adjusting locking levers must be tight and secure before making a cut. If blade adjustment shifts while cutting, it may cause binding and KICKBACK.

FUNCTIONAL DRAWINGS

Caution! Always unplug saw before changing blades, servicing or adjusting saw.

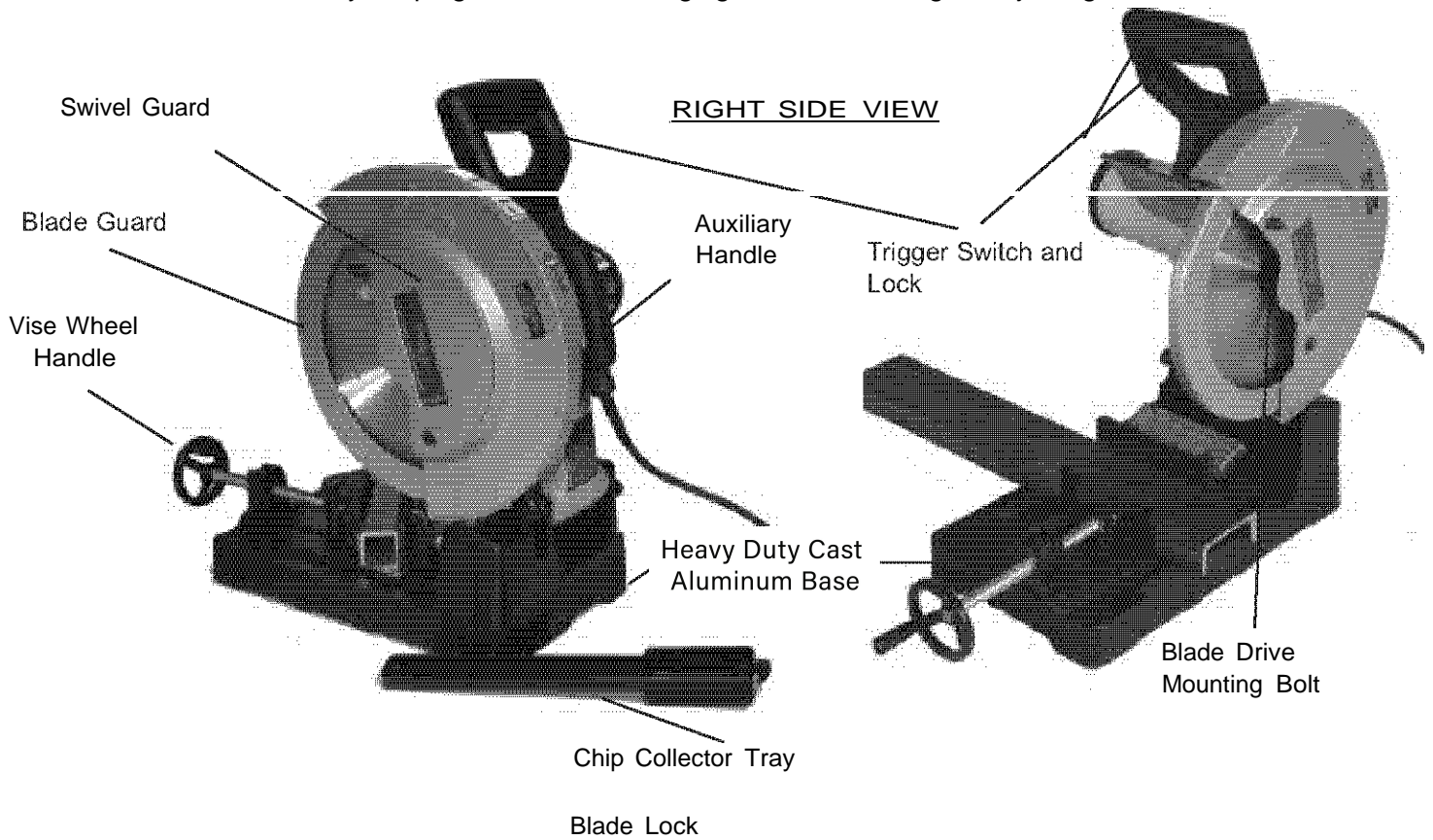

LEFT SIDE VIEW

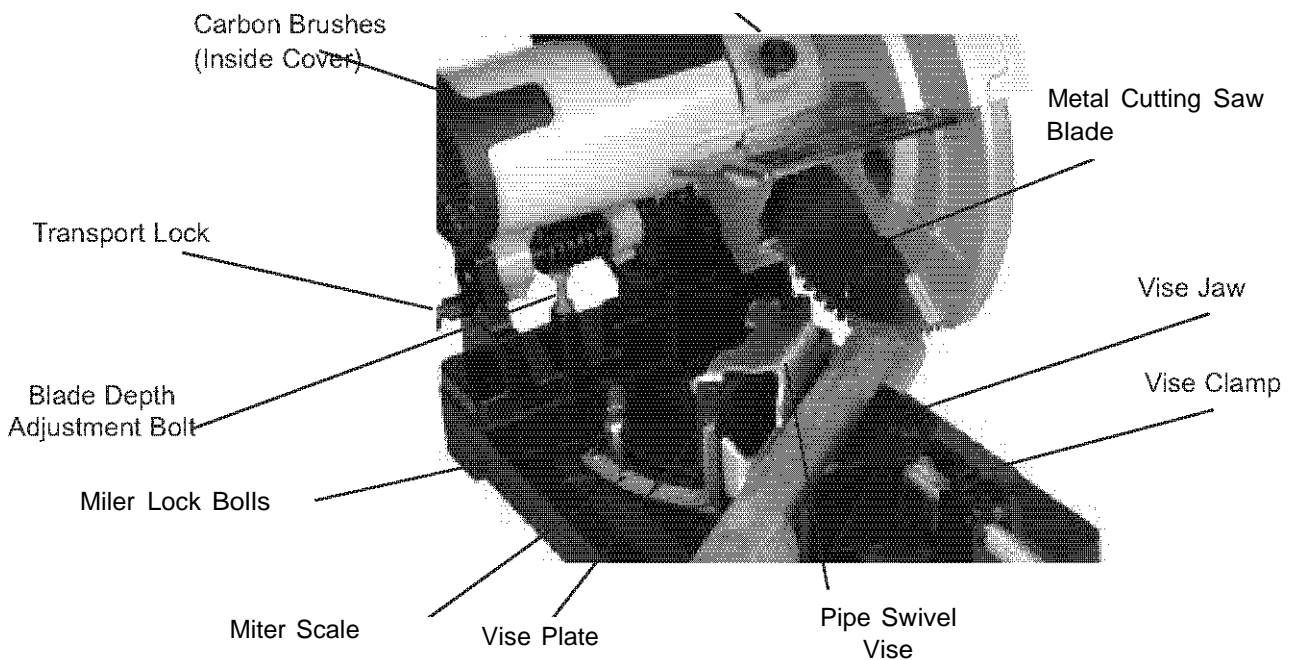

STEELMAX

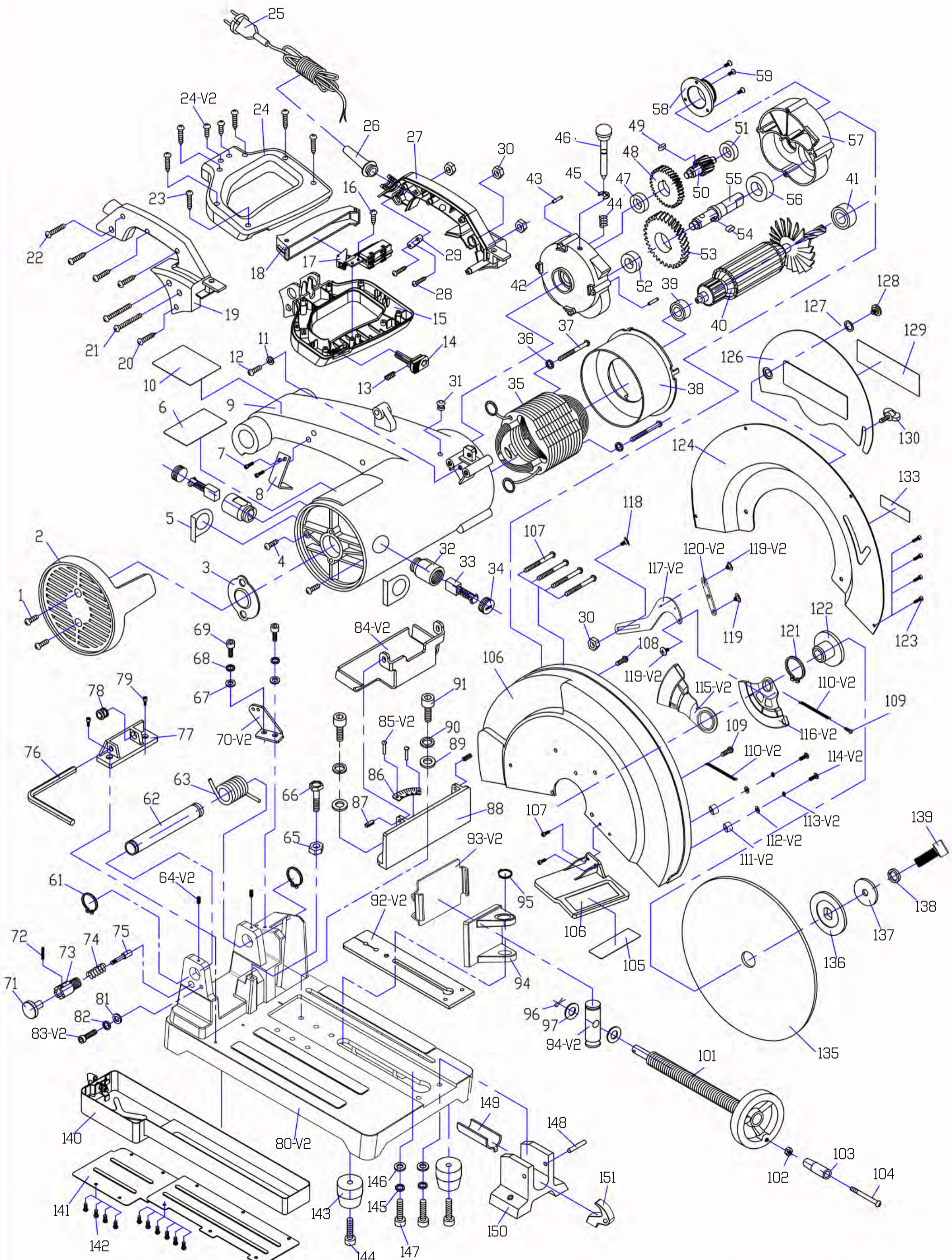

STEELMAX Parts List

ITEM	DESCRIPTION	QTY	ITEM	DESCRIPTION	QTY	ITEM	DESCRIPTION	QTY
1	SCREW M5X15	2	56	BEARING (6204)	1	113-V2	SPRING WASHER 4	2
2	END COVER	1	57.	GEAR HOUSING-RIGHT	1	114-V2	SCREW M4X10	2
3.	BEARING CAP	1	58	BEARING CAP	1	115-V2	SMALL MOVABLE COVER	1
4.	SCREW M5X10	2	59.	SCREW M4X12	3	116-V2	BIGGER MOVABLE COVER	1
5.	PAPER PAD	2	60	FLAT WASHER 24	2	117-V2	LEVER	1
6.	NAME PLATE	1	61	ARM AXIS	1	118	SCREW 4	1
7	HEX SCREW M5X15	2	62	LOAD SPRING	1	119-V2	SCREW 1	3
8.	DEPTH LIMIT	1	64-V2	SREW M5X13	2	120-V2	LEVER (三)	1
9.	MOTOR HOUSING	1	65.	NUT M8	1	116	RETAINING RING 42	1
10.	WARNING LABEL	1	66.	BOLT M8X50	1	117	INNER FLANGE	1
11	SPRING WASHER	1	67	WASHER 6	2	118	SCREW M4X16	4
12	SCREW M5X10	1	68	SPRING WASHER 6	2	126	STEEL COVER	1
13	SPRING	1	69	HEX SCREW M6X20	2	129	WARNING LABER	1
14.	THUMB SWITHCH	1	70-V2	RETRACTING LEVEL SEAT	1	130	SWIVEL GUARD	1
15.	HANDLE-BOTTOM HALF	1	71	TRANSPORT LOCK	1	131	WASHER	1
16	SCREW ST4.2X12	1	72.	PIN 3X18	1	132	SCREW	1
17.	MAIN SWITCH	1	73.	LOCK SEATR	1	133	LOGO LABEL	1
18	SWITCH PADDLE	1	74	SPRING	1	134	WING NUT	1
19	CARRY HANDLE-LEFT HALF	1	75.	PIN	1	135	SAW BLADE	1
20.	SCREW ST4.2X25	1	76.	HEX SCREW 8MM	1	136	OUTTER FLANGE	1
21	SCREW M5X6C	2	77	WRENCH SEAT	1	137	WASHER	1
22	SCREW M5X30	1	78	RETAINING RUBBER	1	138	WASHER 10	1
23.	SCREW ST4.2X19	9	79	SCREW M5X15	2	139	HEX BOLT M10X25	1
24-V2	SCREW ST4.2X15	2	80-V2	SAW BASE	1	140	CHIP BOX	1
24	HANDLE-TOP HALF	1	81	WASHER 8	1	141	CHIP BOX SEAT	1
25.	POWER CORD	1	82	SPRING WASHER 8	1	142	SCREW M4X10	10
26	CORD BOOT	1	83-V2	HEX BOLT M8X35	1	143	RUBBER FOOT	2
27.	CARRY HANDLE-RIGHT HALF	1	84-V2	SWIVEL VISE	1	144	HEX BOLT M8X35	2
28.	SCREW ST4.2X15	2	85-V2	RIVET 3X8	2	145	FLAT WASHER8	2
29	CORD CLAMP	1	90	MITER SCALE	1	146	SPRING WAHSER 8	2
30	SCREW M5	4	91	PIN 6X14	2	147	HEX BOLT M8X30	2
31.	RUBBER SLEEVE	1	92.	WISE PLATE	1	148	PIN	1
32	BRUSH HOLDER	2	93	WASHER	2	149	CLAMP	1
33	CARBON BRUSH	2	94	SPRING WASHER 10	2	150	SUPPORT	1
34.	BRUSH CAP	2	95	HEX BOLT M10X25	2	151	PAD	1
35	STATOR	1	92-V2	INLAY	1	148		
36	SPRING WASHER 5	2	93-V2	WISE CLAMP	1	49		
37	SCREW M5X80	2	94-V2	WISE JAW	1	50.		
38	WIND BAFFLE	1	97	RETAINING RING22	1	151		
39	BEARING (6200)	1	98	PIN 3X26	1	52		
40	ARMATURE	1	99	WASHER 12	2	53		
41	BEARING (6202)	1	100	WISE JAW AXIS	1	154		
42	GEAR HOUSING-LEFT	1	101	THREAD HANDLE	1	55.		
43	PIN A5X18	2	102	NUT M6	1	56.		
44.	SPRING	1	103	WHEEL HANDLE	1	157		
45.	RETAINING RING8	1	104	SCREW M6X54	1	58		
46	SPINDLE LOCK	1	105	WARNING LABEL(三)	1	159		
47	BEARING(6000)	1	106	EYE PROTECTION	1	160.		
48	SMALLER GEAR	1	107	SCREW M4X12	2	161.		
49.	KEY 5X12	1	108	SAFETY COVER	1	62		
50	OUTPUT SHAFT	1	109	SCREW M5X90	4	163		
51.	BEARING (6200)	1	110	SCREW M5X12	1	64		
52.	BEARING (6001)	1	109-V2	SCREWM4X10	2	165		
53.	BIGGER GEAR	1	110-V2	LOAD SPRING	2	166		
54.	KEY 6X12	1	111-V2	RUBBER RING	2	67		
55.	OUTPUT SHAFT	1	112-V2	FLAT WASHER 4	2	68		

ASSEMBLY

Your Steelmax® brand saw is shipped complete and protected inside its shipping box.. Remove all contents from the box and inspect to ensure no damage was incurred during shipping. Your S14 Metal Cutter package should also include the following:

DESCRIPTION	PART #	QTY
OPERATOR'S MANUAL		1
EARPLUGS (2)	STEELMAX80289	1
SAFETY GOGGLES	STEELMAX80290	1
8MM WRENCH	SMS14-76	1
14" STEEL BLADE (OPTIONAL)	SM-BLL-14	1

GETTING STARTED



CAUTION!

ALWAYS DISCONNECT THE SAW FROM POWER SOURCE BEFORE MAKING ADJUSTMENTS.

Refer to the "Functional Description" on page 8 and "Exploded View" drawing on page 10. If required, install an authorized metal cutting saw blade by first loosening wingnut (item 134) and rotating the swivel guard (item 130) up and out of the way. Then loosen the 8mm blade hex bolt and remove the outer blade flange and washer. Verify the correct seat of blade onto the inner blade flange lip. Always check blade installation for proper direction of rotation. From the front of saw, blade travels downward. Improper mounting will cause blade wobble and a possible hazardous condition. Reinstall blade bolt and flanges. Position Swivel guard and secure with thumb screw (item# 134).

ADJUSTING THE VISE

The vise has two positions for optimal cutting and a quick release swivel vise (item 88) for use with pipe, tubing and round profiles. Always use the vise in the most forward position that will completely cut through the material. Smaller profiles can lift out of the vise more easily when the vise is in the rear most position. Larger material requires the vise be moved to the rear position. To move the vise, proceed as follows:

Loosen the right side hex bolt and remove (item 95) using the supplied 8mm hex wrench. Loosen and remove the left side miter lock bolt (item 91). Move the vise to the desired position and reinstall.

The thread vise wheel handle and movable vise jaw should be positioned to tightly grip material to be cut.

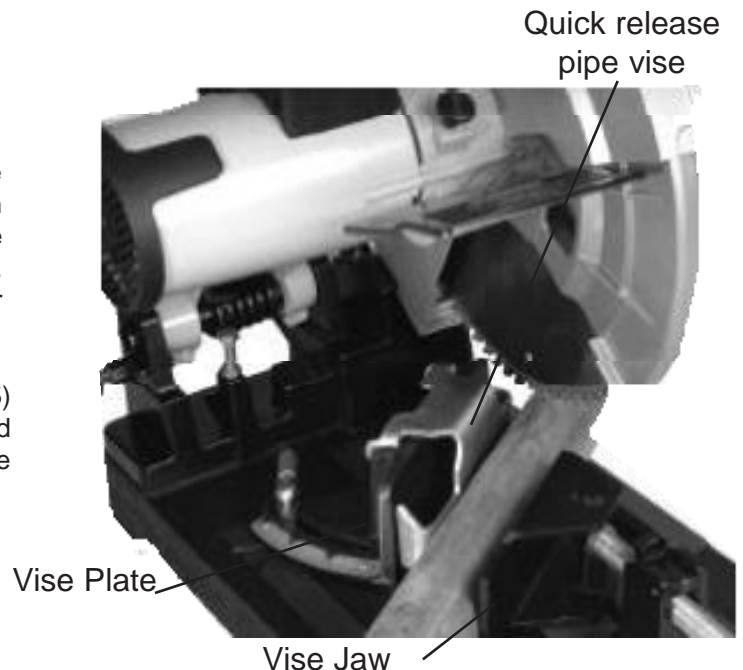

WHAT YOU SHOULD KNOW BEFORE SAWING



NEVER START THE SAW WITH CUTTING EDGE OF SAW BLADE CONTACTING WORK SURFACE. DO NOT RETRACT BLADE GUARD (ITEM# 115) MANUALLY. GUARD RETRACTS AUTOMATICALLY.

ALWAYS CHECK BLADE DOWN-STOP BOLT AND LOCK NUT (ITEM # 65-66) FOR CORRECT POSITIONING BEFORE FIRST USE AND AFTER EACH BLADE CHANGE. FAILURE TO DO SO COULD RESULT IN PERSONAL INJURY DUE TO BLADE CONTACT WITH SAW BASE OR CHIP BOX.

1. After installation of saw blade or before first use, adjust down-stop bolt so that blade does not contact chip tray bottom when blade is in the full down position.

WHAT YOU SHOULD KNOW WHILE SAWING

1. Select the correct saw blade appropriate to the material being cut. (mild steel, thin steel, stainless steel or aluminum)
2. The material surface should be clean and level, free from rust, dirt, scale, and other debris.
3. Material may become heat treated if flame cut. Always avoid cutting near these areas whenever possible.
4. Adjust the vise plate to the desired miter angle by loosening the left and right Miter Lever Lock bolts (item# 91) at the left of the vise plate and the right Miter Lock (item 95) at the right side of vise. Refer to "Exploded View".
5. When cutting smaller profiles, vise plate may be moved forward to aid in cutting quality and to minimize pull-out from the vise. Miter can be set by observing index marks printed on vise bracket.
6. Connect machine to power source.
7. Firmly grasp guide handle and trigger handle switch (item# 14, 15 and 24).
8. Position material in the saw vise and align cutting line with blade. Adjust the front and rear vise plates as necessary to firmly hold material in the desired position.
9. When ready, start saw motor by activating trigger switch (item# 17).
10. Slowly approach material edge and gently apply pressure until saw blade has established a cutting groove in the material.
11. Apply smooth, constant pressure without over-loading saw motor.



IF SAW MOTOR SHOULD STALL OR STOP BEFORE A COMPLETE CUT IS MADE ALWAYS REMOVE BLADE FROM MATERIAL BEFORE ATTEMPTING TO RESTART MOTOR. FAILURE TO DO SO COULD RESULT IN PERSONAL INJURY.

AFTER COMPLETING THE CUT

1. After the cut, release trigger switch to the "OFF" position.
2. When saw motor completely stops, clear both drop piece and material from vise.

OPERATION (continued)

FOR BEST PERFORMANCE, EMPTY THE CHIP COLLECTOR BOX OFTEN.

EMPTYING THE CHIP COLLECTOR BOX

WARNING!

ALWAYS DISCONNECT THE SAW FROM POWER SOURCE BEFORE CHANGING BLADES, CLEARING CHIPS OR MAKING ADJUSTMENTS.

1. Turn the Chip Collector Box retaining thumbscrew (see below).
2. Remove chip collector box from the back of saw.
3. Empty chip collector completely. Clean all debris from saw body.
4. Install chip collector box in saw and fasten securely by tightening thumbscrews.

WARNING!

FAILURE TO INSTALL COLLECTOR BOX TOTALLY AND SECURE MAY RESULT IN UNCONTROLLED DISCHARGE OF CHIPS AND OPERATOR INJURY. ALWAYS VERIFY PROPER INSTALLATION OF CHIP BOX AND CHECK FREQUENTLY.

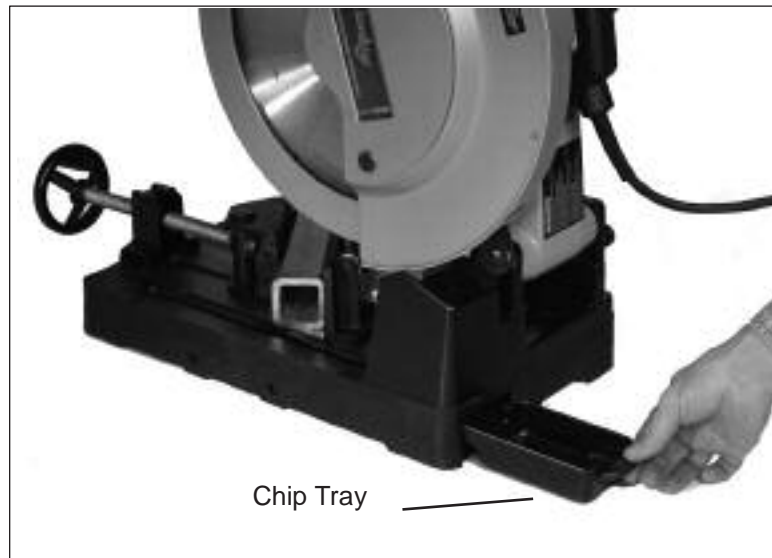

WARNING!

MOTOR DOWN-STOP BOLT AFFECTS HOW FAR BLADE TRAVELS INTO THE CHIP COLLECTOR BOX. AN IMPROPERLY ADJUSTED DOWN-STOP CAN HIT THE BOTTOM OF BOX, CAUSING AN EJECTION HAZARD. ALWAYS CHECK DOWN-STOP ADJUSTMENT AFTER REPLACING SAW BLADES OR SERVICING MACHINE.

MAINTENANCE

WARNING!

ALWAYS DISCONNECT THE SAW FROM POWER SOURCE BEFORE CHANGING BLADES, CLEARING CHIPS OR MAKING ADJUSTMENTS.

CHANGING SAW BLADES

Refer to the diagram to the right.

1. Place saw on a level, secure surface.
2. Move the swivel guard (item #130) by loosening the thumb screw (item #134) and rotating it to expose the blade retaining bolt.
3. Engage spindle lock (item# 46).
4. Using supplied hex wrench, loosen and remove the blade drive mounting bolt, washer and outer blade drive flange (items# 136-139).
5. Move the blade guard up and out of the way (item # 115).
6. Remove saw blade. (item 135)
7. Thoroughly clean inner and outer blade drive flanges and blade mounting surface before installing new blade.
8. Verify blade rotation is correct.
9. Reverse process to install new blade.

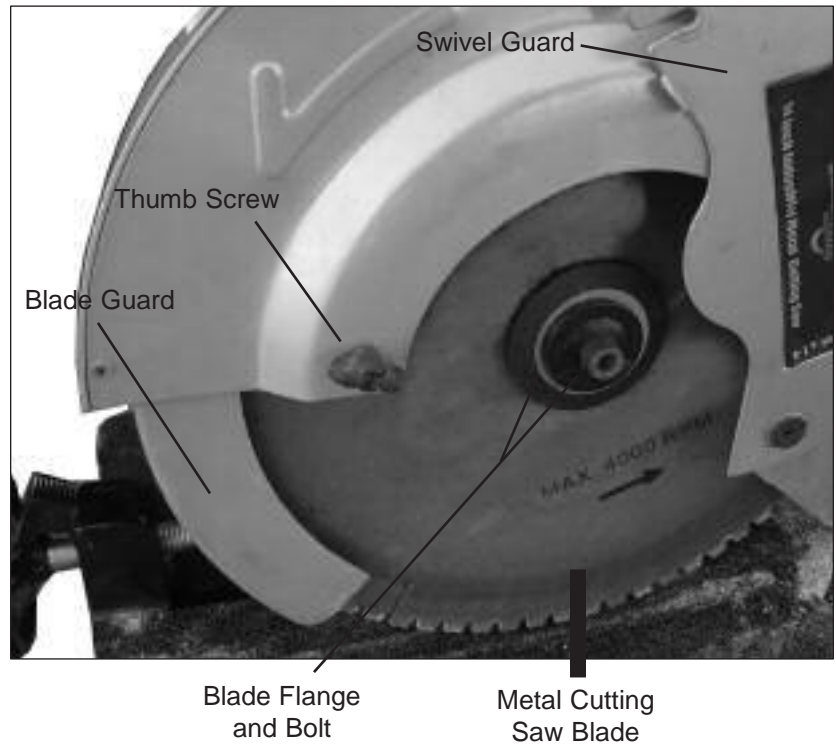

REPLACING MOTOR BRUSHES

Refer to the diagram to the right.

1. Place saw on level, secure surface.
2. Tip saw on its right side (blade side down).
3. Remove two (2) motor end cover screws and remove the cover and motor bearing spring washer.
4. Remove the two brush caps and slide brushes out. Caution! Do not rotate brushes if re-installing. Note exact position when re-installing brushes.
3. If the carbon rod is less than 6mm or if there are signs of burning or other wear, replace the brushes.
4. Reverse the process to re-assemble saw.

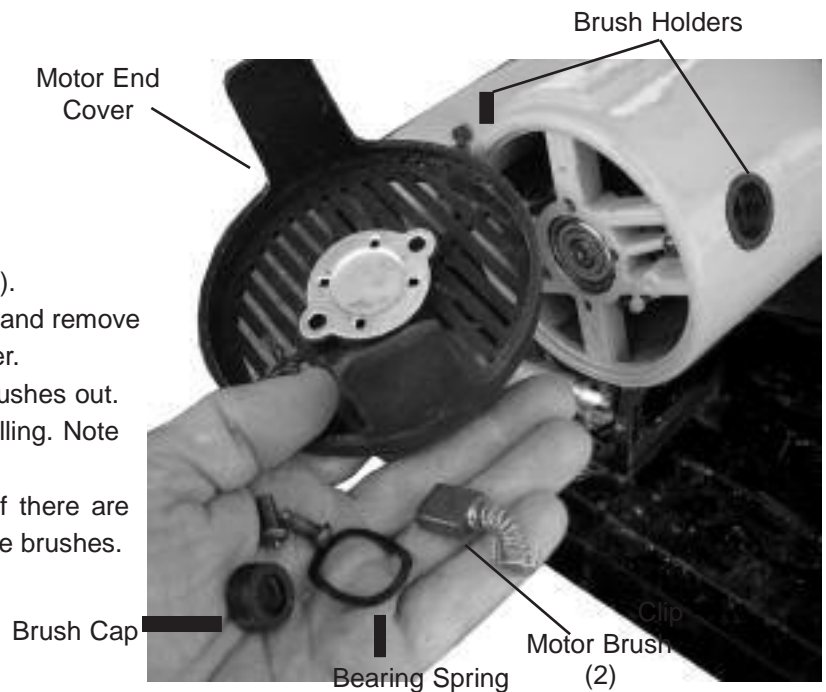

TROUBLESHOOTING CHECKLIST

S14 14" METAL CUTTER



ALWAYS DISCONNECT THE SAW FROM POWER SOURCE BEFORE TROUBLESHOOTING.

1. Machine will not turn on

- Inspect power cord for damage. Check continuity. Replace if needed. (PN SMS14-25)
- Inspect brushes for excessive wear. Replace if needed. (PN SMS14-33) (2)
- Do not exceed 30 minutes run time without cool down of saw.
- Check trigger switch for continuity. Replace if needed. (PN SMS14-17)

2. Losing Power

- Inspect brushes and replace if needed. (PN SMS14-33) (2)
- Extension cord too long. Limit cord length to 50' or less.
- Extension cord too thin. Use 12 AWG or larger.

3. Blade Guard Sticks

- Remove guard and remove any foreign material.
Guard must move freely. Use light grease on mating contact surfaces to aid in movement.
- Check guard return spring for sufficient tension. Replace if spring is weak. (PN SMS14-113)
- Check guard for distortion. Replace if distorted or damaged. (PN SMS14-115)

4. Blade Spins on Spindle

- Check for proper tightness and installation. Inspect inner blade flange (PN SMS14-117) and outer blade flange (PN SMS14-136) for wear or damage. Replace if wear is excessive.
- Check flange mating surfaces for flatness. Replace if excessive distortion exists.
- Check to ensure flat washer is present between bolt head and outer blade drive flange.

5. Low Blade Life/Teeth Chipping

- Wrong blade for the type of material.
 - SM-BLL-14 for mild steel up to 1" solid.
 - SM-BLL-14-AL for aluminum up to 1" solid.
 - SM-BLL-14-SS for stainless steel up to 1/2" solid.
 - SM-BLL-14-TS for thin steel up to 1/4" solid.
- Aggressive contact with blade into material. The blade must be allowed to do the work.
- Too much vibration due to insufficient clamping, worn or bent blade, or worn parts (see "Saw Vibrates" below).

6. Saw Vibrates

- Check blade for tightness.
- Inspect inner blade flange (PN SMS14-117) and outer blade drive flange (PN SMS14-136) for wear or damage. Replace if needed.
- Check to ensure work is properly clamped. Both primary and cut-off piece can cause vibration.
- Check miter lock for tightness. (PN SMS14-91)
- Check blade teeth for missing carbide, bends or cracks.

SPECIFICATIONS

Model S 14

DIMENSIONS AND SPECIFICATIONS

Height	340mm (13.4")
Width	340mm (13.4")
Length	466mm (18.4")
Weight	58.5lbs. - 26.8 kg
Motor	120V (14.6 A) or 230V (7.6 A) - 1750W 50~60 Hz / 1450 RPM
Blade Arbor	25.4mm (1.0")
Blade Diameter	355mm (14.0")
Depth of Cut/Pipe or Angle (maximum)	82.5mm (3.25")
Depth of Cut/Plate or Bar (maximum)	13mm Mild Steel (1") 13mm Aluminum (1") 8mm Stainless Steel (1/2")

ACCESSORIES

Saw Blades

Application	Part #
For cutting mild steel to 1"	SM-BLL-014
For cutting thin steel to 1/4"	SM-BLL-14-TS
For cutting aluminum to 1"	SM-BLL-14-AL
For cutting stainless steel to 1/2"	SM-BLL-14-SS

Steelmax Tools LLC.

Phone 303-690-9146

Fax 303-690-9172

www.steelmax.com e-mail: sales@steelmax.com

PRODUCT REGISTRATION AND WARRANTY CARD

Thank you for purchasing a Steelmax® product!
Please fill out this form and return promptly so that we may register your purchase.

Model# _____ Serial # _____ Date of Purchase _____

Steelmax Tools LLC

121 Southpointe Drive, Bridgeville PA, 15017
Phone 303-690-9146 Fax 303-690-9172

www.steelmax.com e-mail: sales@steelmax.com

Please detach and retain this top portion for your records.

Fax 303-690-9172

Mr. Mrs. Ms. Miss

First Name

Last Name

Company Name

Street Address

City

State

Zip

Phone Number

Fax Number

E-mail Address

May we contact you by: Mail Fax E-mail Address

Model

Serial#

Date of Purchase

Where did you purchase your Steelmax product from

What are the top two reasons that influenced your purchase of this Steelmax brand product?

Reputation

Value for price

Web site

Safety features

Magazine ad

Availability

Recommendation

Reputation of retailer

Style/Appearance

Quality/Durability

Other

In your opinion, what is the BEST industry publication you regularly read? _____

Is this: A first time purchase? An additional unit? A replacement unit? For which brand? _____

Additional comments: _____

Thank You! We value your answers and input.

Yes, put me on the Steelmax email list for special offers.

Please tape here before mailing.

First Class
Postage
Required

Steelmax Tools LLC
121 Southpointe Drive, Bridgeville PA, 15017

ATTENTION: WARRANTY DEPARTMENT

