

AUTO-FEED DOUBLE-SIDE HEAVY DUTY BEVELER

ABM-29

HIGH-EFFICIENCY, SELF FEEDING BEVELER

The Steelmax ABM-29 Auto Feed Beveler creates weld-ready bevels between 20 and 45 degrees on plate thickness from 3/8" (10mm) up to 1-5/8" (40mm). Utilizing a fast and silent shearing technology the ABM29 can produce bevels at travel speeds up to 6-1/2' per minute (2 m/min) with a maximum cutting capacity of 3/4" (20mm) per pass. Equipped with an ergonomically designed trolley that permits rapid inversion of the beveling head, the ABM29 eliminates the need to flip the plate to produce bottom side bevels – eliminating material handling and greatly improving plate processing times.

For added versatility, the ABM-29 can operate in a stationary mode for machining smaller workpieces or pipes with an internal diameter greater than 4 inches (100mm). The built-in ergonomic trolley includes a hydraulic height adjustment from 27 to 39 inches (685 to 1000mm), providing flexibility and ease of use.



FEATURES

- Heavy Duty beveling machine with speeds up to 6-1/2' per min (2 m/min)
- Up to 3/4" (20 mm) bevel width in one pass
- Continuous bevel angle adjustment between 20 and 45 degrees
- Integrated trolley facilitates top & bottom beveling
- Pipe Machining with minimum ID of 4" (100 mm)
- Continuous milling height adjustment
- Overload protection & low noise machine
- Reverse travel mode can be used to free jammed tooling

Bevel depth adjustment



Single shearing cutter for various materials.



Dedicated trolley. Locks to stiffen machine for stationary work unlocks for easy movement in workspace.

Steelmax.

The tools of innovation.

AUTO-FEED DOUBLE-HEAVY DUTY BEVELER

ABM 29 Technical Specifications	
Voltage	3x400 V / 3x480 V + PE, 50-60 Hz / 3x240 50-60 Hz
Power	3000 W
Spindle speed	4 rpm (for 50 Hz); 5 rpm (for 60 Hz)
Bevel angle	20° - 45°
Maximum bevel width	1-1/8" (29 mm)
Maximum bevel in one single run	3/4" (20 mm)
Maximum height of cut	9/16" (14.5 mm)
Minimum plate thickness	3/8" (10 mm)
Maximum plate thickness	1- 5/8" (40 mm) (50 mm*)
Minimum plate width	3-1/8" (80 mm)
Bevel length per minute	5-1/2 ft/ min (1.7 m/min for 50 Hz)
Minimum pipe ID	6" (150 mm)
Weight	1190.5 lbs (540 kg)
Product Code	SM-ABM-29 (480 V) SM-ABM-29-230 (230 V)

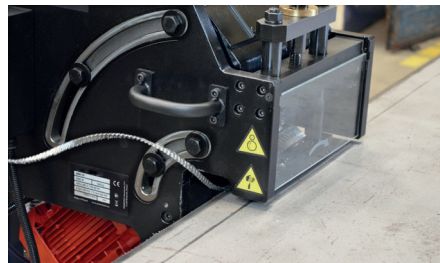
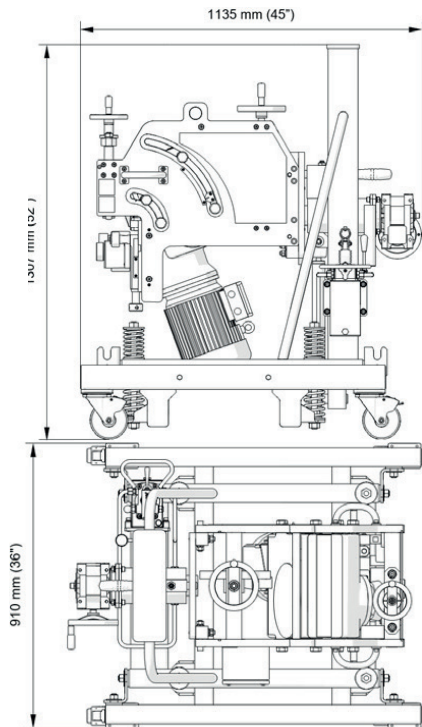

Automatic feed allows ABM-29 to travel along the top and bottom edges of the plate.



Inverted Operation

The trolley enables 180-degree up-and-down rotation for top and bottom bevels without flipping the plate. It features easy one-man operation and a mechanical lock to secure the machine in either position.

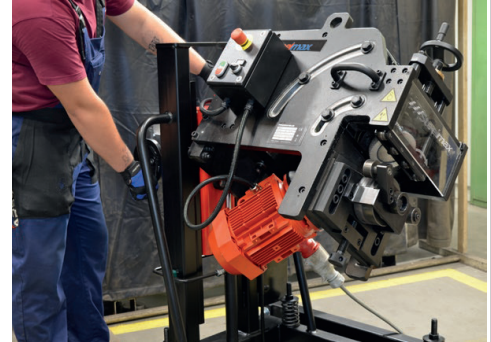

ABM 29 can bevel pipes with ID bigger than 6" (150 mm)

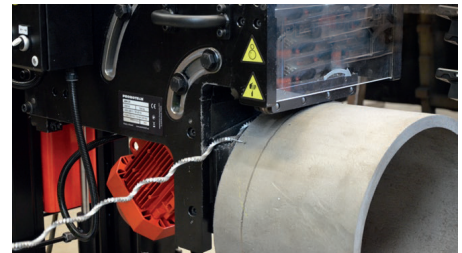

Shipping Set

- Beveling machine with trolley
- Transport box
- Set of tools
- Shearing cutter
- 14 mm, 8 mm, 6 mm, 4 mm hex wrench
- Operator's manual

Steelmax.

The tools of innovation.

For ordering and customer service, or to request detailed product information or demonstration videos, contact:

303-690-9146

STEELMAX.COM

sales@Steelmax.com

Fax: 303-690-9172