



The tools of innovation.

## OPERATOR'S MANUAL

### HFB360

### HYDRAULIC MIG WIRE FEEDER BOOM



301 W. Mineral Ave, Suite 103, Littleton CO. 80120

Phone: 303-690-9146 Fax: 303-690-9172

<https://www.steelmax.com> e-mail: [sales@steelmax.com](mailto:sales@steelmax.com)

## Contents

---

1. Application and General Information .....	3
2. Technical data.....	3
3. STARTUP AND OPERATION .....	6
3.1 Lifting .....	6
3.2 Lowering .....	6
3.3 Rotation .....	6
4. DECLARATION OF CONFORMITY .....	8

301 W. Mineral Ave, Suite 103, Littleton CO 80120

Phone: 303-690-9146 Fax: 303-690-9172

<https://www.steelmax.com> e-mail: [sales@steelmax.com](mailto:sales@steelmax.com)



## 1. APPLICATION AND GENERAL INFORMATION

The Hydraulic MIG Wire Feeder Boom (HFB360) was created as a useful part of a welder's workplace, that is able to carry both power source and wire feeder. The design and construction of the HFB360 makes the welders job more ergonomic and productive. Lifting, lowering and rotation functions of the Hydraulic MIG Wire Feeder boom extends the workstation area and also makes it easy to move the unit across the shop floor. Before starting to work with the Hydraulic MIG Wire Feeder Boom, please take time to go through this instruction manual including Technical data, Startup and Operation information.

## 2. TECHNICAL DATA:

Hydraulic Wire Feeder Boom Technical Specifications	
<b>Model Number</b>	<b>HFB-360</b>
Reach	118" (3000 mm)
Rotation Angle	0-360°
Maximum load (wire feeder, wire)	110 lbs (50 kg)
Dimensions (L x W x H)	148" x 63" x 94" (min) / 135" (max ) 3750 mm x 1600 mm x 2390 mm (min) / 3430 mm (max)
Wire Feeder Height Range	50" - 135" (1300-3430 mm)
Weight	733 lbs (330 kg)
Hydraulic Fluid	required AW46 or Synthetic 46 oil (1.5 -2 quarts)
Part Number	SM-WFB-HFB-360

This document is copyright protected.

Copying, using, or distributing without permission of STEELMAX TOOLS LLC is prohibited

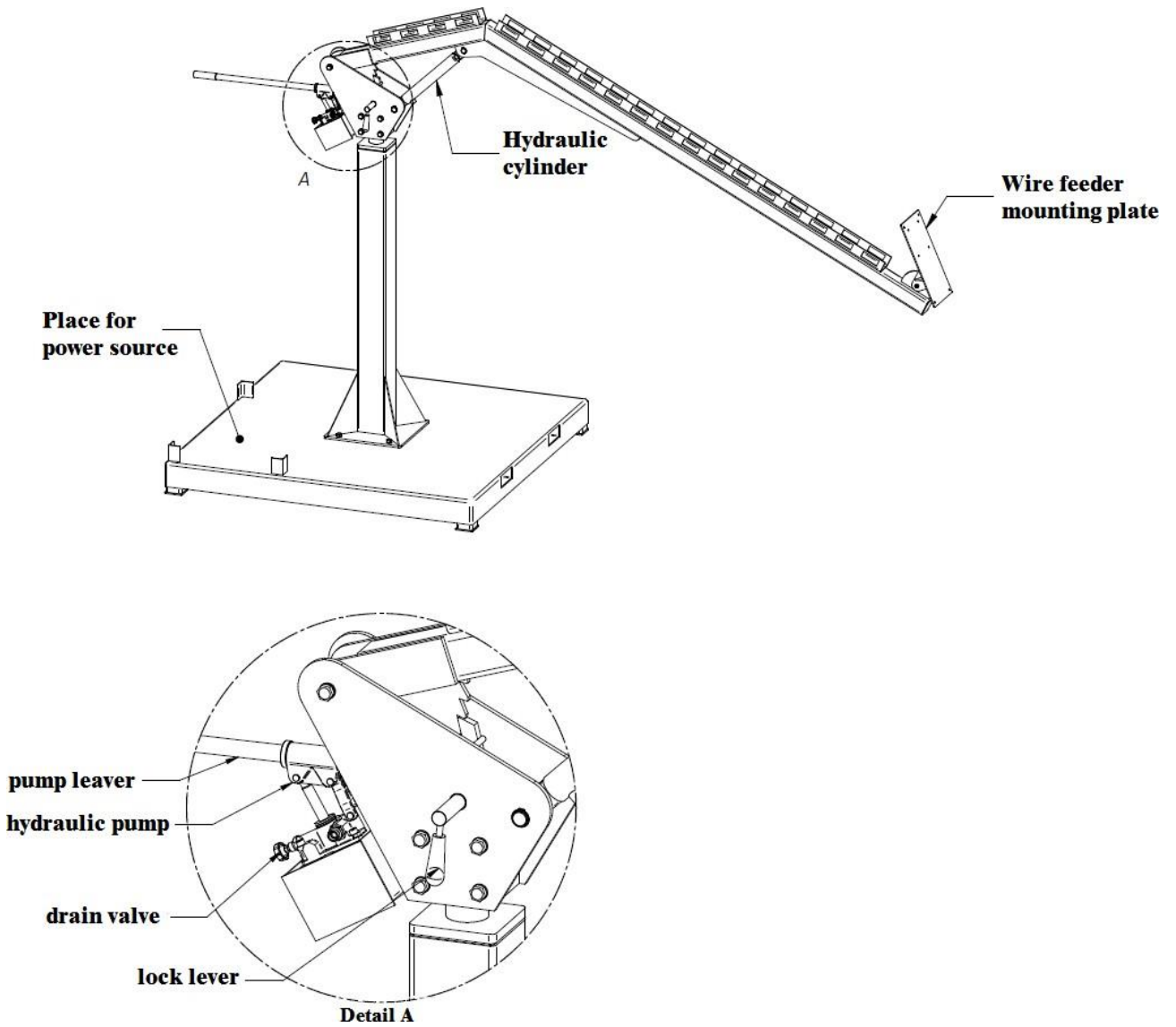

Fig. 1 View of the Hydraulic Wire Feeder Boom

This document is copyright protected.

Copying, using, or distributing without permission of STEELMAX TOOLS LLC is prohibited

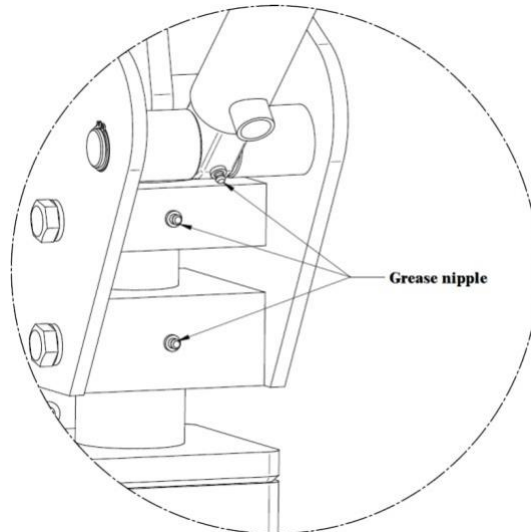

Fig. 2 Grease nipple locations

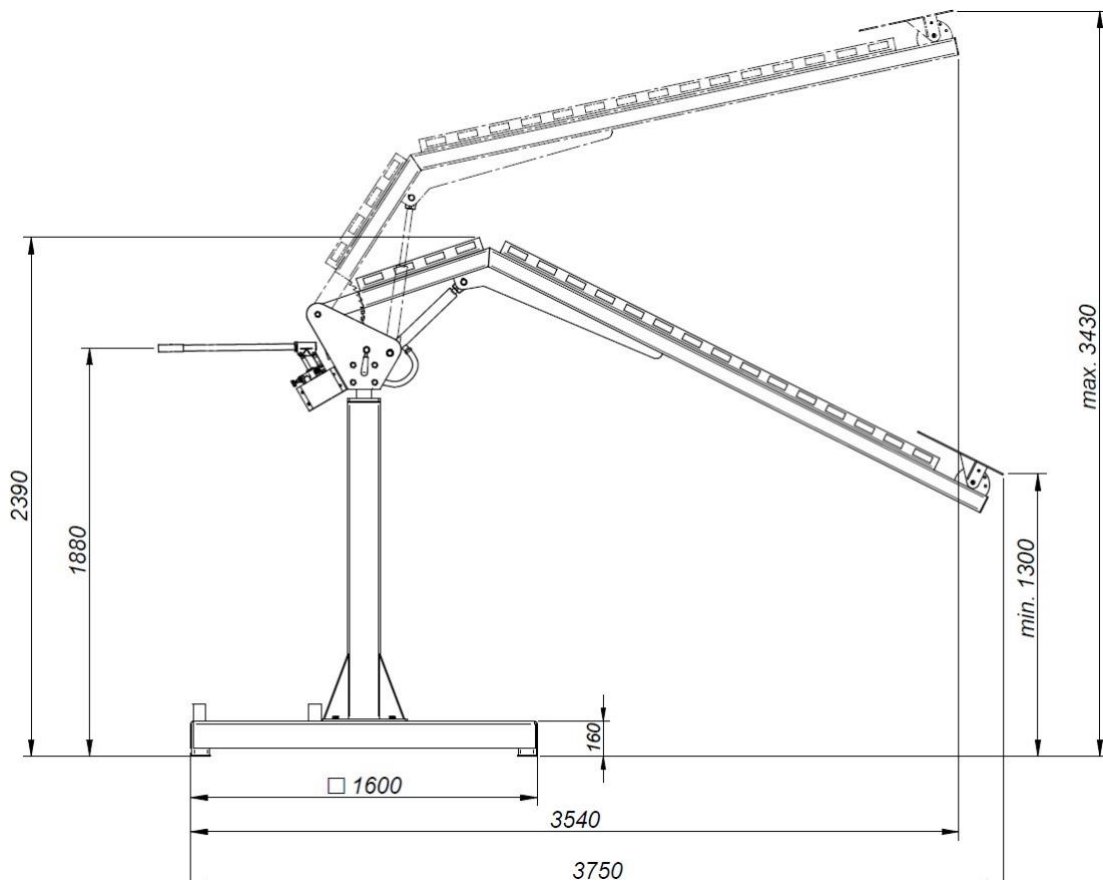

Fig. 3 Dimensions of the boom

This document is copyright protected.

Copying, using, or distributing without permission of STEELMAX TOOLS LLC is prohibited



## 3. STARTUP AND OPERATION

### 3.1 Lifting

To lift the arm of the Hydraulic MIG Wire Feeder Boom you need to take following steps:

1. Close the Drain Valve by turning it clockwise until its completely shut (Fig.1),
2. Lift the arm of the Hydraulic MIG Wire Feeder Boom to its desired height using pump lever (up and down motion of the lever, Fig. 1). As the arm gets closer to its maximum height, you will feel resistance building up on the pump lever as the hydraulic cylinder reaches its maximum length.

### 3.2 Lowering

To lower the arm of the Hydraulic MIG Wire Feeder Boom you need to take following steps:

1. Slightly raise the arm of the Hydraulic MIG Wire Feeder Boom according to previous point (3.1 Lifting).
2. Turn the lock lever clockwise (Fig. 1)
3. While holding the lock lever, slowly turn the drain valve anticlockwise to control the vertical motion of the arm.
4. When arm reaches desired height, release the lock lever to allow the pawl to fall into the rack and close the drain valve by turning it clockwise.

### 3.3 Rotation

To rotate the Hydraulic MIG Wire Feeder Boom arm, lower it to the minimum height position and rotate it by pushing its far end. Make sure that the wires are not twisted around the pole. **NEVER ROTATE THE HYDRAULIC MIG WIRE FEEDER BOOM USING THE PUMP LEVER.**

This document is copyright protected.

Copying, using, or distributing without permission of STEELMAX TOOLS LLC is prohibited



### **ATTENTION:**

- The Hydraulic MIG Wire Feeder Boom should be used only for purposes that it was designed to address – detailed in the APPLICATION AND GENERAL INFORMATION section.
- When the Hydraulic MIG Wire Feeder Boom is in use it must be placed on a solid and leveled floor.
- Working space of the Hydraulic MIG Wire Feeder Boom should be large enough to allow its easy movement in all directions.  
(please see TECHNICAL DATA section).
- During lowering of the Hydraulic MIG Wire Feeder Boom's arm make sure that there is no one standing in its working area.
- During rotation of the Hydraulic MIG Wire Feeder Boom's arm make sure that there is no one standing in its working area.
- It is recommended that the working area of the Hydraulic MIG Wire Feeder Boom is marked and protected from others than operator/welder, by marking a radius of minimum 3m from its pole.
- The welding power source needs to be mounted securely in the designated area of the Hydraulic MIG Wire Feeder Boom base (Fig. 1). Wire feeder needs to be placed securely on mounting plate using the grid of pre-drilled holes.
- Do not exceed the maximum weight capacity of the Hydraulic MIG Wire Feeder Boom (please see TECHNICAL DATA section)
- Apply grease into grease nipples (Fig. 2) at least every 8 weeks (more often if the Hydraulic MIG Wire Feeder Boom is used heavily).
- The Hydraulic MIG Wire Feeder Boom can be transported by forklift by using dedicated holes in its base. During transport the arm of the Hydraulic MIG Wire Feeder must be lowered to the minimum height position and secured against rotating.

This document is copyright protected.

Copying, using, or distributing without permission of STEELMAX TOOLS LLC is prohibited

---

## 4. DECLARATION OF CONFORMITY

### *CE Declaration of Conformity*

*PROMOTECH-KM sp. z o.o.ul.*

*Wł. Piotrowskiego 40 18-100*

*Łapy*

*Poland*

We declare with full responsibility  
that:

### **Hydraulic Wire Feeder Boom**

is manufactured in accordance with the following standards:

- EN ISO 12100
- EN 349
- EN 13155
- EN ISO 12480-1
- EN ISO 12482-1

and satisfies safety regulations of the guideline 2006/42/EC.

Łapy, 21 July 2020

\_\_\_\_\_  
Karol Zadykowicz – Managing Director

301 W. Mineral Ave, Suite 103, Littleton CO. 80120

Phone: 303-690-9146 Fax: 303-690-9172

<https://www.steelmax.com> e-mail: [sales@steelmax.com](mailto:sales@steelmax.com)