



# Model S7

Portable Metal Cutting Circular Saw

# OPERATOR'S MANUAL

E238208



**LISTED**  
Metal Cutting Tool  
90SM

J1Y-KZ-185



**WARNING!**

TO REDUCE THE RISK OF INJURY, USER MUST READ AND UNDERSTAND INSTRUCTION MANUAL.



EYE PROTECTION  
REQUIRED



HEARING PROTECTION  
REQUIRED



NEVER PLACE  
FINGERS NEAR  
CUTTING AREA.  
BEWARE OF  
ROTATING  
MACHINE PARTS



LINE VOLTAGE  
PRESENT



MODEL S7 (120V)

Serial # \_\_\_\_\_

Date of Purchase \_\_\_\_\_

# Portable Metal Cutting Circular Saw

Congratulations on your purchase of a Steelmax® brand portable Metal Cutter Saw. Please complete and mail your product registration card. Doing so will validate your machine's warranty period and ensure prompt service if needed. We sincerely thank you for selecting a product from Steelmax.

## TABLE OF CONTENTS

Limited Warranty . . . . .	.2
General Safety Rules and Specific Instructions . . . . .	.3-4
Specific Safety Rules and Symbols . . . . .	.5-8
Functional Drawings . . . . .	.9
Exploded View . . . . .	.10
Parts List . . . . .	.11
Assembly . . . . .	.12
Operation . . . . .	.13
Operation (Laser) . . . . .	.14
Emptying the Chip Chamber . . . . .	.15
Maintenance / Changing Saw Blades . . . . .	.16
Troubleshooting Checklist . . . . .	.17
Specifications . . . . .	.18
Accessories . . . . .	.18

## LIMITED WARRANTY

STEELMAX RESERVES THE RIGHT TO MAKE IMPROVEMENTS AND  
MODIFICATIONS TO DESIGN WITHOUT PRIOR NOTICE.

Steelmax. will, within twelve (12) months from the original date of purchase, repair or replace any goods found to be defective in materials or workmanship, provided the product warranty registration card has been returned to Steelmax within thirty (30) days of purchase date. This warranty is void if the tool being returned has been used to cut materials beyond the recommendations in the Owner's Operating Manual or if the saw has been damaged by accident, neglect, improper service, or other causes not arising out of defects in materials or workmanship. This warranty does not apply to machines and/or components which have been altered, changed, or modified in any way, or subjected to use beyond recommended capacities and specifications. Electrical components are subject to respective manufacturers' warranties. All goods returned defective shall be returned prepaid freight to Steelmax, which shall be the buyer's sole and exclusive remedy for defective goods. Steelmax reserves the right to optionally repair or replace it with the same or equivalent item. There is no warranty – written or verbal - for saw blades. In no event shall Steelmax be liable for loss or damage resulting directly or indirectly from the use of merchandise or from any other cause. Steelmax is not liable for any costs incurred on such goods or consequential damages. No officer, employee or agent of Steelmax is authorized to make oral representations of fitness or to waive any of the foregoing terms of sale and none shall be binding on Steelmax.

Questions relating to this limited warranty should be directed to the company's head office in Littleton, CO or call 303-690-9146

STEELMAX  
801. W.MINERAL AVE, SUITE 103., LITTLETON, CO 80120

# GENERAL SAFETY RULES

## **WARNING!** Read and Understand all Instructions.

Failure to follow all instructions listed below, may result in electric shock, fire and/or serious personal injury.

### **SAVE THESE INSTRUCTIONS**

#### **Work Area**

- *Keep Your Work Area Clean and Well Lit.*
- **Cluttered benches and dark areas invite accidents.**
  
- *Do not operate power tools in explosive atmospheres, such as in the presence of flammable liquids, gases, or dust. Power tools create sparks which may ignite the dust or fumes.*
  
- *Keep bystanders, children, and visitors away while operating a power tool. Distractions can cause you to lose control.*

#### **Electrical Safety**

- *Grounded tools must be plugged into an outlet properly installed and grounded in accordance with all codes and ordinances. Never remove the grounding prong or modify the plug in any way. Do not use any adapter plugs. Check with a qualified electrician if you are in doubt as to whether the outlet is properly grounded. If the tools should electrically malfunction or break down, grounding provides a low resistance path to carry electricity away from the user.*
  
- *Avoid body contact with grounded surfaces such as pipes, radiators, ranges and refrigerators. There is an increased risk of electric shock if your body is grounded.*
  
- *Don't expose power tools to rain or wet conditions. Water entering a power tool will increase the risk of electric shock.*
  
- *Do not abuse the cord. Never use the cord to carry the tools or pull the plug from an outlet. Keep cord away from heat, oil, sharp edges or moving parts. Replace damaged cords immediately. Damaged cords increase the risk of electric shock.*
  
- *When operating a power tool outside, use an outdoor extension cord marked "W-A" or "W." These cords are rated for outdoor use and reduce the risk of electric shock.*

(Note) When using an extension cord, be sure to use one heavy enough to carry the current your product will draw. An undersized cord will cause a drop in line voltage resulting in loss of power and overheating. The recommended minimum is a 12 gauge extension cord not exceeding 50 feet.

# GENERAL SAFETY RULES (continued)

## **Personal Safety**

- *Stay alert, watch what you are doing and use common sense when operating a power tool. Do not use tool while tired or under the influence of drugs, alcohol, or medication. A moment of inattention while operating power tools may result in serious personal injury.*
- *Dress properly. Do not wear loose clothing or jewelry. Contain long hair. Keep your hair, clothing, and gloves away from moving parts. Loose clothes, jewelry, or long hair can be caught in moving parts.*
- *Avoid accidental starting. Be sure switch is off before plugging in. Carrying tools with your finger on the switch or plugging in tools that have the switch on invites accidents.*
- *Remove adjusting keys or switches before turning the tool on. A wrench or a key that is left attached to a rotating part of the tool may result in personal injury.*
- *Do not overreach. Keep proper footing and balance at all times. Proper footing and balance enables better control of the tool in unexpected situations.*
- *Use safety equipment. Always wear eye protection. Dust mask, non-skid safety shoes, hard hat, or hearing protection must be used for appropriate conditions.*

## **Tool Use and Care**

- *Use clamps or other practical way to secure and support the workpiece to a stable platform. Holding the work by hand or against your body is unstable and may lead to loss of control.*
- *Do not force tool. Use the correct tool for your application. The correct tool will do the job better and safer at the rate for which it is designed.*
- *Do not use tool if switch does not turn it on or off. Any tool that cannot be controlled with the switch is dangerous and must be repaired.*
- *Disconnect the plug from the power source before making any adjustments, changing accessories, or storing the tool. Such preventive safety measures reduce the risk of starting the tool accidentally.*
- *Store idle tools out of reach of children and other untrained persons. Tools are dangerous in the hands of untrained users.*
- *Maintain tools with care. Keep cutting tools sharp and clean. Properly maintained tools, with sharp cutting edges are less likely to bind and are easier to control.*
- *Check for misalignment or binding of moving parts, breakage of parts, and any other condition that may affect the tools operation. If damaged, have the tool serviced before using. Many accidents are caused by poorly maintained tools.*
- *Use only accessories that are recommended by the manufacturer for your model. Accessories that may be suitable for one tool, may become hazardous when used on another tool.*

## **SERVICE**

- *Tool service must be performed only by qualified repair personnel. Service or maintenance performed by unqualified personnel could result in a risk of injury.*
- *When servicing a tool, use only identical replacement parts. Follow instructions in the Maintenance section of this manual. Use of unauthorized parts or failure to follow Maintenance Instructions may create a risk of electric shock or injury.*

# SPECIFIC SAFETY RULES AND SYMBOLS

## WARNING!

DO NOT OPERATE MACHINE IF WARNING AND/OR INSTRUCTION LABELS ARE MISSING OR DAMAGED.  
CONTACT STEELMAX FOR REPLACEMENT LABELS.

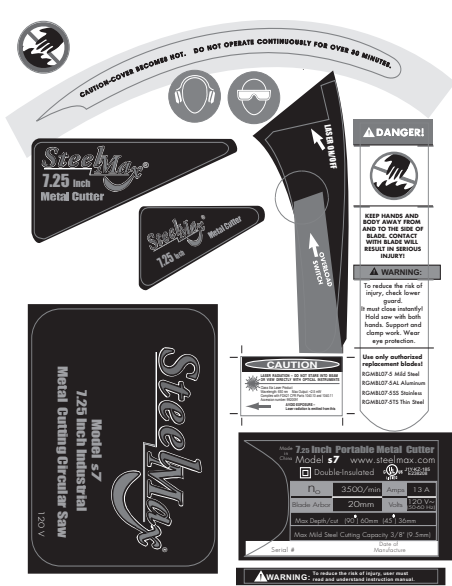

EYE PROTECTION  
REQUIRED



HEARING PROTECTION  
REQUIRED



NEVER PLACE  
FINGERS NEAR  
CUTTING AREA



LINE VOLTAGE  
PRESENT

Symbol	Description
V .....	volts
A .....	amperes
Hz .....	hertz
min .....	minutes
~ .....	alternating current
n <sub>0</sub> .....	no load speed
 .....	Double Insulated

1. Only use Steelmax® brand approved saw blades. Unauthorized blades may be dangerous!
2. Keep saw blades securely fastened. Check blade flanges for debris before installing any new blade.
3. Do not use dull or broken blades. Check blades often for condition and wear.
4. Check chip collector cover for proper fit to minimize the risk of flying debris.
5. Beware of ejecting chips. They become HOT both during and after cutting.
6. Always make provisions for safe handling of excess material.
7. Keep bottom of base plate free from dirt and other debris.

To obtain an additional copy of your manual (PN LIT102SM), please contact Steelmax at:

Ph. 303.690.9146

Fx. 303.690.9172

Web [www.steelmax.com](http://www.steelmax.com)

## SPECIFIC SAFETY RULES (continued)

- DANGER! — Keep hands and body away from and to the side of the blade. Contact with blade will result in serious injury.
- WARNING! — To reduce the risk of injury, check lower guard. It must close instantly! Hold saw with both hands. Support and clamp work. Wear eye protection.

### **Additional Specific Safety Rules:**

DANGER! Keep hands away from cutting area and blade. Keep your second hand on auxiliary handle, or motor housing. If both hands are holding the saw, they cannot be cut by the blade.

- Keep your body positioned to either side of the saw blade, but not in line with the saw blade. KICKBACK could cause the saw to jump backwards. (See "Causes and Operator Prevention of Kickback.")
- Do not reach underneath the work. The guard cannot protect you from the blade below the work.
- Check lower guard for proper closing before each use. Do not operate saw if lower guard does not move freely and close instantly. Never clamp or tie the lower guard into the open position. If saw is accidentally dropped, lower guard may be bent. Raise the lower guard and make sure it moves freely and does not touch the blade or any other part, in all angles and depths of cut.
- Check the operation and condition of the lower guard spring. If the guard and the spring are not operating properly, they must be serviced before use. Lower guard may operate sluggishly due to damaged parts, gummy deposits, or a buildup of debris.
- Always observe that the lower guard is covering the blade before placing saw down on bench or floor. An unprotected, coasting blade will cause the saw to walk backwards, cutting whatever is in its path. Be aware of the time it takes for the blade to stop after switch is released.
- NEVER hold piece being cut in your hands or across your leg. It is important to support the work properly to minimize body exposure, blade binding, or loss of control.
- Hold tool by insulated gripping surfaces when performing an operation where the cutting tool may contact hidden wiring or its own cord. Contact with a "live" wire will also make exposed metal parts of the tool "live" and shock the operator.
- When ripping always use a rip fence or straight edge guide. This improves the accuracy of cut and reduces the chance for blade binding.
- Always use blades with correct size and shape (diamond vs. round) arbor holes. Blades that do not match the mounting hardware of the saw will run eccentrically, causing loss of control.
- Never use damaged or incorrect blade washer or bolts. The blade washer and bolt were specially designed for your saw, for optimum performance and safety of operation.

## SPECIFIC SAFETY RULES (continued)

### LASER ALIGNMENT GUIDE PRECAUTIONS

Note: (not all models are equipped with a laser)



#### **DANGER!**

**LASER RADIATION. AVOID DIRECT EYE EXPOSURE. DO NOT STARE INTO THE LASER LIGHT SOURCE.** Never aim light at another person or object other than the workpiece. Laser light can damage your eyes.



Avoid Exposure - Laser Radiation is emitted from this aperture.



#### **WARNING!**

**DO NOT USE TINTED GLASSES TO ENHANCE THE LASER LIGHT.** Tinted glasses will reduce overall vision for the application and interfere with the normal operation of the tool.



#### **WARNING!**

**NEVER AIM THE BEAM AT A WORKPIECE WITH A REFLECTIVE SURFACE.** Highly polished or similar reflective surfaces are not recommended for laser use where eye exposure is possible due to reflection. These surfaces could reflect the beam back toward the operator or bystanders.  
**ALWAYS CONSIDER THE PATH OF POSSIBLE BEAM DEFLECTION.**

## SPECIFIC SAFETY RULES (continued)

### **CAUSES AND OPERATOR PREVENTION OF KICKBACK**

Kickback is a sudden reaction to a pinched, bound or misaligned saw blade, causing an uncontrolled saw to lift up and out of the workpiece toward the operator. When the blade is pinched or bound tightly by the kerf (saw cut) closing down, the blade stalls and the motor reaction drives the unit rapidly back toward the operator. If the blade becomes twisted or misaligned in the cut, the teeth at the back edge of the blade can dig into the top surface of the material causing the blade to climb out of the kerf and jump back toward operator. Kickback is the result of tool misuse and/or incorrect operating procedures or conditions and can be avoided by taking proper precautions as given below:

Maintain a firm grip with both hands on the saw and position your body and arm to allow you to resist KICKBACK forces. KICKBACK forces can be controlled by the operator, if proper precautions are taken.

When blade is binding, or when interrupting a cut for any reason, release the trigger and hold the saw motionless in the material until the blade comes to a complete stop. Never attempt to remove the saw from the work or pull the saw backward while the blade is in motion or KICKBACK may occur. Investigate and take corrective actions to eliminate the cause of blade binding.

When restarting a saw in the workpiece, center the saw blade in the kerf and check that saw teeth are not engaged into the material. If saw blade is binding, it may walk up or KICKBACK from the workpiece as the saw is restarted.

Support large panels to minimize the risk of blade pinching and KICKBACK. Large panels tend to sag under their own weight. Supports must be placed under the panel on both sides, near the line of cut and near the edge of the panel.

Do not use dull or damaged blade. Dull or improperly set blades produce narrow kerf causing excessive friction, blade binding and KICKBACK.

Blade depth and bevel adjusting locking levers must be tight and secure before making a cut. If blade adjustment shifts while cutting, it may cause binding and KICKBACK.



# FUNCTIONAL DRAWINGS



Caution! Always unplug saw before changing blades, servicing or adjusting saw.

## RIGHT SIDE VIEW

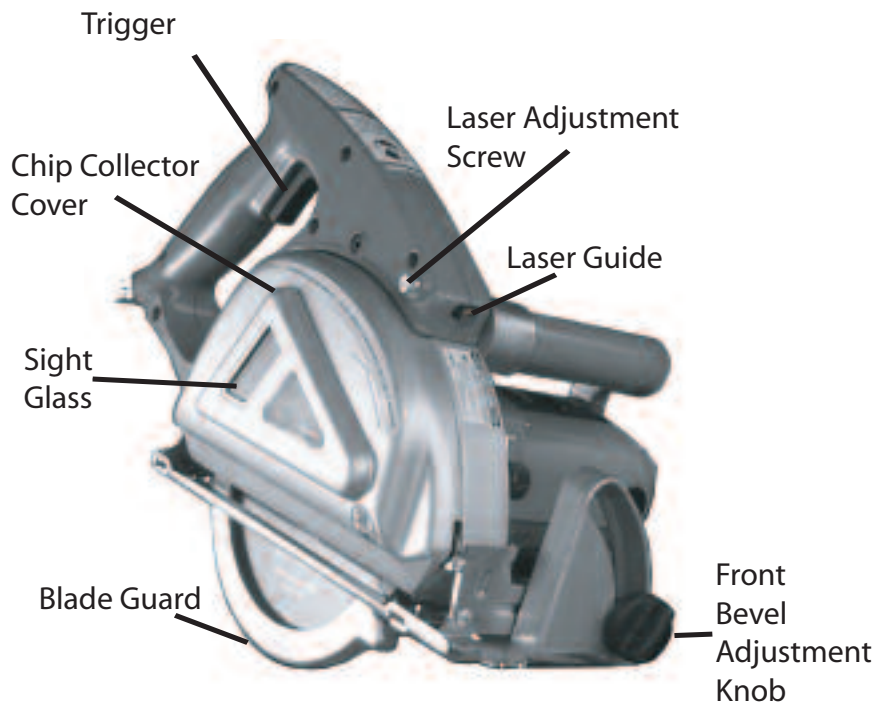

## LEFT SIDE VIEW

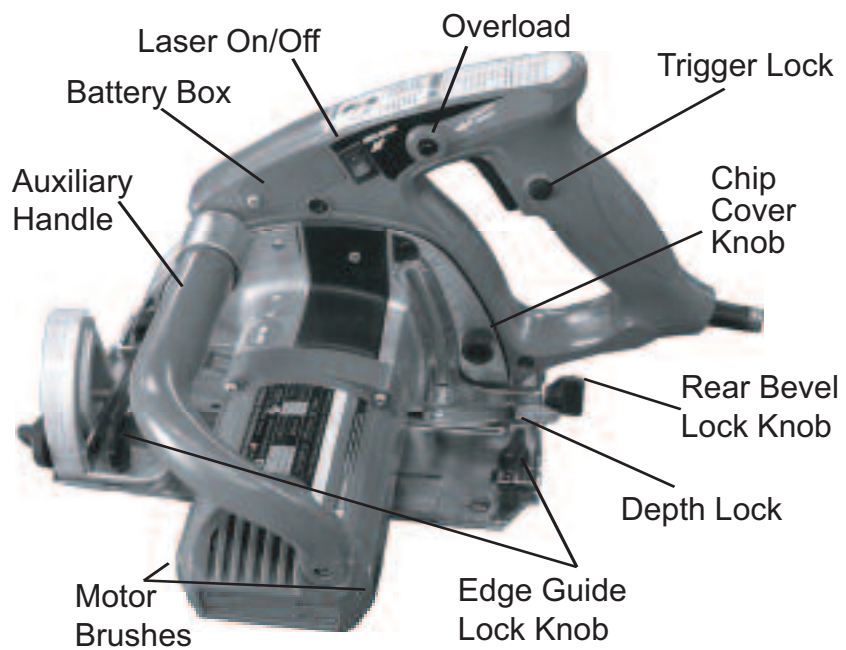

# EXPLODED VIEW

## Steelmax S7 Exploded View

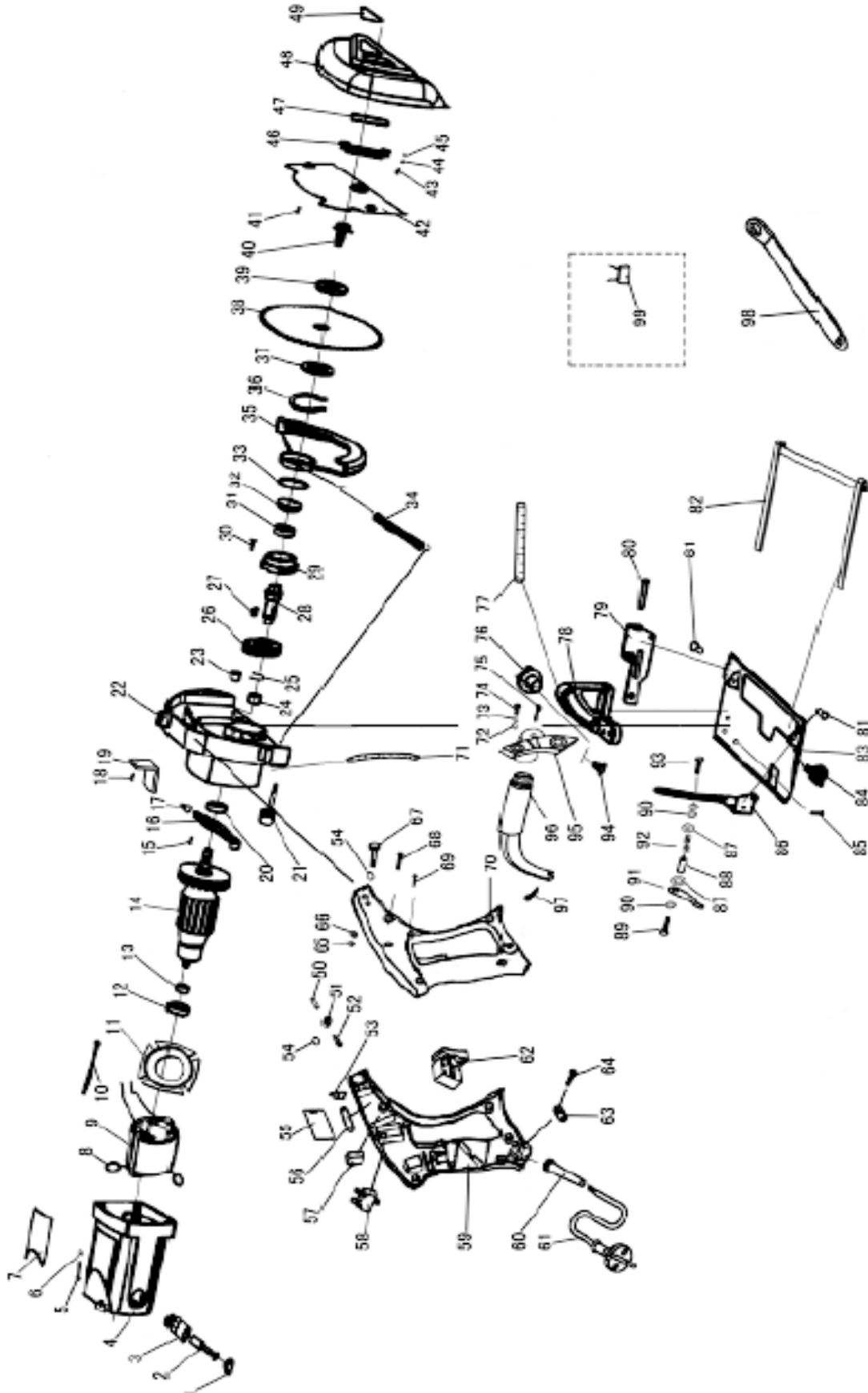

# PARTS LIST

ITEM	DESCRIPTION	PART #	QTY	ITEM	DESCRIPTION	PART #	QTY
1	BRUSH HOLDER CAP	SMS7-1	2	55	BATTERY COVER	SMS7-55	1
2	CARBON BRUSH	SMS7-2	2	56	BATTERY	SMS7-56	2
3	BRUSH HOLDER	SMS7-3	2	57	LASER SWITCH	SMS7-57	1
4	MOTOR HOUSING	SMS7-4	1	58	OVERLOAD SWITCH	SMS7-58	1
5	SCREW M5X35	SMS7-5	4	59	HANDLE, LEFT SIDE	SMS7-59	1
6	SPRING WASHER Ø5	SMS7-6	4	60	STRAIN RELIEF	SMS7-60	1
7	MOTOR LABEL	SMS7-7	1	61	POWER CORD	SMS7-61	1
8	BRUSH CONTACT SPRING	SMS7-8	2	62	SWITCH	SMS7-62	1
9	FIELD WINDING	SMS7-9	1	63	STRAIN RELIEF CLIP	SMS7-63	1
10	SELF TAPPING SCREW ST5X60	SMS7-10	2	64	SELF TAPPING SCREW ST4X14	SMS7-64	2
11	FAN GUARD	SMS7-11	1	65	CIRCLIP Ø4	SMS7-65	1
12	BEARING RUBBER COVER	SMS7-12	1	66	WASHER Ø5	SMS7-66	1
13	BEARING 608	SMS7-13	1	67	LASER ADJUSTMENT SCREW	SMS7-67	1
14	ARMATURE	SMS7-14	1	68	SOCKET HEAD SCREW M5X16	SMS7-68	2
15	FLAT SCREW M4X10	SMS7-15	2	69	SELF TAPPING SCREW ST4X20	SMS7-69	6
16	BLADE LOCK	SMS7-16	1	70	HANDLE, RIGHT SIDE	SMS7-70	1
17	BLADE LOCK SPRING	SMS7-17	1	71	DEPTH LABEL	SMS7-71	1
18	SCREW M4X10	SMS7-18	1	72	WASHER Ø5	SMS7-72	5
19	MOTOR WIRE COVER	SMS7-19	1	73	SPRING WASHER Ø5	SMS7-73	2
20	BEARING 6001	SMS7-20	1	74	SCREW M5X14	SMS7-74	2
21	THUMBSCREW, CHIP COVER RETAINING	SMS7-21	1	75	SCREW ST4.2X18	SMS7-75	1
22	MAIN BODY HOUSING	SMS7-22	1	76	BEVEL LOCK KNOB	SMS7-76	1
23	RUBBER BUMPER	SMS7-23	1	77	BEVEL LABEL	SMS7-77	1
24	BEARING Ø 16XØ 10X10	SMS7-24	1	78	BEVEL BRACKET	SMS7-78	1
25	CIRCLIP FOR SHAFT Ø15	SMS7-25	1	79	SHOE BEVEL BRACKET	SMS7-79	1
26	LARGE GEAR	SMS7-26	1	80	PIVOT PIN	SMS7-80	1
27	WOODRUFF KEY 4X13	SMS7-27	1	81	RIVET Ø5X10	SMS7-81	2
28	OUTPUT SHAFT	SMS7-28	1	82	EDGE GUIDE	SMS7-82	1
29	BEARING COVER	SMS7-29	1	83	SHOE PLATE	SMS7-83	1
30	FLAT SCREW M6X16	SMS7-30	2	84	BEVEL LOCKING KNOB, REAR	SMS7-84	1
31	BEARING 6002	SMS7-31	1	85	SCREW, M6X8	SMS7-85	3
32	BEARING COVER	SMS7-32	1	86	SHOE DEPTH BRACKET	SMS7-86	1
33	SLIP RING	SMS7-33	2	87	WASHER Ø10	SMS7-87	2
34	SPRING, BLADE GUARD	SMS7-34	1	88	CONNECTING ROD	SMS7-88	1
35	BLADE GUARD	SMS7-35	1	89	HEX HEAD SCREW	SMS7-89	1
36	CIRCLIP, BLADE GUARD RETAINER	SMS7-36	1	90	WASHER Ø6	SMS7-90	3
37	INNER BLADE FLANGE	SMS7-37	1	91	LEVER, DEPTH LOCK	SMS7-91	1
38	METAL CUTTING SAW BLADE	RGMBL07-5	1	92	SPRING	SMS7-92	1
39	OUTER BLADE FLANGE	SMS7-39	1	93	HEX HEAD SCREW M6X14	SMS7-93	1
40	BOLT, BLADE RETAINING M8X14-L	SMS7-40	1	94	BOLT, BEVEL KNOB	SMS7-94	1
41	SCREW, M5X12	SMS7-41	2	95	BRACKET, LEFT HANDLE	SMS7-95	1
42	INNER CHIP COVER PLATE	SMS7-42	1	96	LEFT HANDLE	SMS7-96	1
43	SCREW, M4X10	SMS7-43	2	97	SCREW ST5X12	SMS7-97	1
44	SPRING WASHER Ø4	SMS7-44	2	98	BLADE WRENCH	SMS7-98	1
45	WASHER Ø4	SMS7-45	2	99	CAPACITOR	SMS7-99	1
46	SIGHT GLASS RETAINER	SMS7-46	1	100	CARRYING CASE	SMS7-100	1
47	SIGHT GLASS	SMS7-47	1	101	WOOD CHIP COVER	SMS7-101	1
48	CHIP COVER	SMS7-48	1				
49	LABEL	SMS7-49	1				
50	LASER	SMS7-50	1				
51	LASER SEAT	SMS7-51	1				
52	LASER CLIP	SMS7-52	1				
53	BATTERY CONTACT	SMS7-53	1				
54	O-RING	SMS7-54	2				

# ASSEMBLY

Your Steelmax® brand saw is shipped complete and protected inside a reusable carrying case. Remove all contents from the case and inspect to ensure no damage was incurred during shipping. Your S7 Metal Cutter package should also include the following:

DESCRIPTION	PART #	QTY
OPERATOR'S MANUAL	LIT102RGM	1
EARPLUGS (2)	RGM80289	1
SAFETY GOGGLES	RGM80290	1
13MM WRENCH	SMS7-98	1
EDGE GUIDE	SMS7-82	1
7.25" STEEL BLADE (OPTIONAL)	RGMBL07-5	1
CARRYING CASE	SMS7-100	1
DISCHARGE COVER FOR WOOD	SMS7-101	1

## GETTING STARTED



ALWAYS DISCONNECT THE SAW FROM POWER SOURCE BEFORE MAKING ADJUSTMENTS.

Refer to the "Functional Drawings" on page 9 and "Exploded View" drawing on page 10. If required, assemble edge guide (item# 82) to shoe plate (item# 83), and adjust edge guide to desired position. Secure with thumb screws. If a blade has not been installed, install an authorized saw blade as detailed in the "Changing Saw Blades" section (page 16). Always adjust front and rear bevel lock knobs and tighten before cutting.

If wood cutting blade is installed, the accessory discharge chip cover should be used. Failure to do so could result in an excess of sawdust in the collector, which may present a fire hazard when combined with hot metal chips.

# OPERATION

## WHAT YOU SHOULD KNOW BEFORE SAWING



NEVER START THE SAW WITH CUTTING EDGE OF SAW BLADE CONTACTING WORK SURFACE. DO NOT RETRACT BLADE GUARD (ITEM# 35) MANUALLY. GUARD RETRACTS AUTOMATICALLY.

## WHAT YOU SHOULD KNOW WHILE SAWING

1. Select the correct saw blade appropriate to the material being cut. (mild steel, stainless steel or aluminum)
2. The material surface should be clean and level, free from rust, dirt, scale, and other debris.
3. Material may become heat treated if flame cut. Always avoid cutting near these areas whenever possible.
3. Adjust the shoe plate to the desired bevel angle by loosening and then re-tightening the Bevel Lever Lock (item# 76) at front of saw and the Rear Bevel Lock at rear of saw. (item 84)
4. When making long, straight cuts in sheet stock, insert the edge guide to the desired width and secure with thumb screws, or use the electronic Laser Guide.
5. Adjust to the proper depth of cut by loosening and re-tightening the rear Lever Lock (item# 91) at rear of saw. In most cases, depth should be set at maximum unless there are obstructions below the work surface. Depth can be set by observing index marks printed on housing along depth bracket.
6. Connect machine to power source.
7. Firmly grasp guide handle and trigger handle switch (item# 96 and 62).
8. Position saw base plate on work surface near the cutting area.
9. While observing Cautions and Warnings above, turn on the Laser On/Off switch. If Laser does not turn on, check batteries. (Note: Laser is not required for saw operation.)
10. When ready, start saw motor by activating trigger switch (item# 62).
11. Slowly approach material edge and gently apply pressure until saw blade has established a cutting groove in the material.
12. Apply smooth, constant pressure without over-loading saw motor.



IF SAW MOTOR SHOULD STALL OR STOP BEFORE A COMPLETE CUT IS MADE ALWAYS REMOVE BLADE FROM MATERIAL BEFORE ATTEMPTING TO RESTART MOTOR. FAILURE TO DO SO COULD RESULT IN PERSONAL INJURY.

## AFTER COMPLETING THE CUT

1. After the cut, release trigger switch to the "OFF" position.
2. When saw motor completely stops, place saw on secure and level surface.
3. Turn Laser On/Off switch to Off position.

## OPERATION (continued)

### USING THE LASER ALIGNMENT GUIDE

#### **DANGER!**

**LASER RADIATION. AVOID DIRECT EYE EXPOSURE. DO NOT STARE INTO THE LASER LIGHT SOURCE.**  
Never aim light at another person or object other than the workpiece. Laser light can damage your eyes.

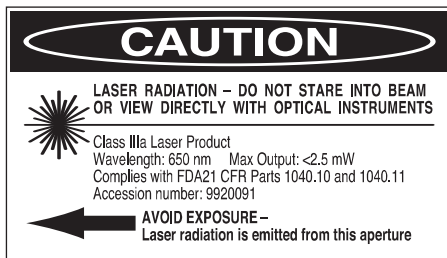

Avoid Exposure - Laser Radiation is emitted from this aperture.

#### **WARNING!**

**DO NOT USE TINTED GLASSES TO ENHANCE THE LASER LIGHT. Tinted glasses will reduce overall vision for the application and interfere with the normal operation of the tool.**

#### **WARNING!**

**NEVER AIM THE BEAM AT A WORKPIECE WITH A REFLECTIVE SURFACE.** Highly polished or similar reflective surfaces are not recommended for laser use where eye exposure is possible due to reflection. These surfaces could reflect the beam back toward the operator or bystanders.  
**ALWAYS CONSIDER THE PATH OF POSSIBLE BEAM DEFLECTION.**



1. While observing Cautions and Warnings above, turn on the Laser/Light On/Off switch. If Laser does not turn on, check batteries. (Note: Laser is not required for saw operation)
2. Turn on saw with Trigger Switch and move saw into material while applying smooth, constant pressure during cutting.
3. When cut is complete, release trigger switch to stop saw motor.
4. Turn Laser/Light On/Off switch to Off position.

## OPERATION (continued)

For best performance and to prevent overheating, empty the chip collector often.

THE S7 SAW IS EQUIPPED WITH A CHIP COLLECTOR COVER (STANDARD) TO CAPTURE METAL CHIPS, AND A DISCHARGE COVER TO EXPEL WOOD CHIPS AS APPROPRIATE. REFER TO THE DESCRIPTIONS BELOW.

### EMPTYING THE CHIP COLLECTOR (METAL CHIP COLLECTOR VERSION)

#### WARNING!

ALWAYS DISCONNECT THE SAW FROM POWER SOURCE BEFORE CHANGING BLADES, CLEARING CHIPS OR MAKING ADJUSTMENTS.

1. Loosen the two Chip Collector Cover Retaining screws (item# 21).
2. Remove chip collector from the right side of saw. (item# 48)
3. Empty chip collector by tipping the cover sideways and letting the chips and debris fall out. Clean all debris from saw body.
4. Install chip collector on saw and fasten securely by tightening thumbscrews.

#### WARNING!

FAILURE TO SECURE THE CHIP COLLECTOR COVER MAY RESULT IN UNCONTROLLED DISCHARGE OF CHIPS AND OPERATOR INJURY. ALWAYS VERIFY PROPER INSTALLATION OF COVER AND CHECK FREQUENTLY.

### INSTALLING THE DISCHARGE CHIP COVER (FOR WOOD CUTTING)

#### WARNING!

ALWAYS DISCONNECT THE SAW FROM POWER SOURCE BEFORE CHANGING BLADES, CLEARING CHIPS OR MAKING ADJUSTMENTS.

1. Loosen the two Chip Collector Cover Retaining screws (item# 21).
2. Remove chip collector from the right side of saw. (item# 48)
3. The discharge cover (item# 101) is designed to be used with a wood blade only. Install the discharge cover in place of the chip collector cover. Wood chips will be ejected out the discharge hole.
4. Install chip collector on saw and fasten securely by tightening the thumbscrews.

S7 saw shown with discharge type cover for wood use.



## MAINTENANCE

### WARNING!

ALWAYS DISCONNECT THE SAW FROM POWER SOURCE BEFORE CHANGING BLADES, CLEARING CHIPS OR MAKING ADJUSTMENTS.

#### CHANGING SAW BLADES

Refer to the diagram below.

1. Place saw on a level, secure surface.
2. Remove chip collector cover (item #48) by loosening the chip cover retaining screws. (Item 21)
3. Engage spindle lock (item# 16).
6. Using supplied wrench, loosen and remove blade drive mounting bolt and outer blade drive flange (item# 39, 40).
7. Remove saw blade. (item 38)
8. Thoroughly clean inner and outer blade drive flanges and blade mounting surface before installing new blade.
9. Reverse process to install new blade.

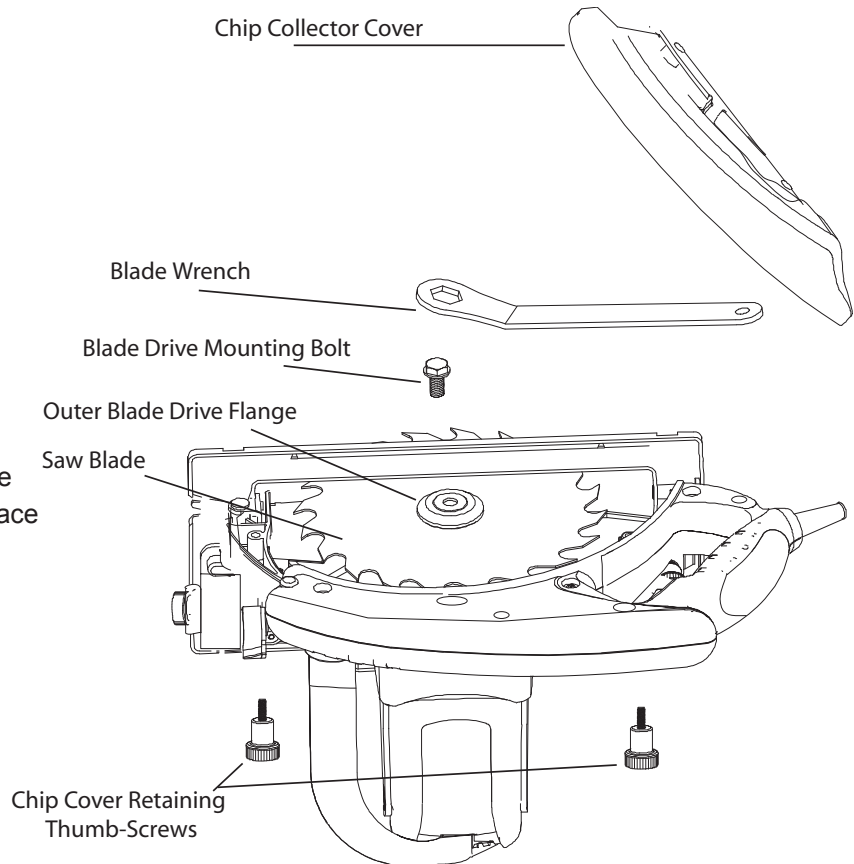

#### REPLACING MOTOR BRUSHES

Refer to the diagram to the right.

1. Place saw on level, secure surface.
2. Remove two (2) motor brush retainer cap screws (item# 1) and slide the brushes out.
3. If the carbon rod is less than 6mm or if there are signs of burning or other wear, replace the brushes.
4. Reverse the process to re-assemble saw.

Note: Always run the saw without load for several minutes after changing brushes. Failure to do so could cause excessive sparking and motor damage.

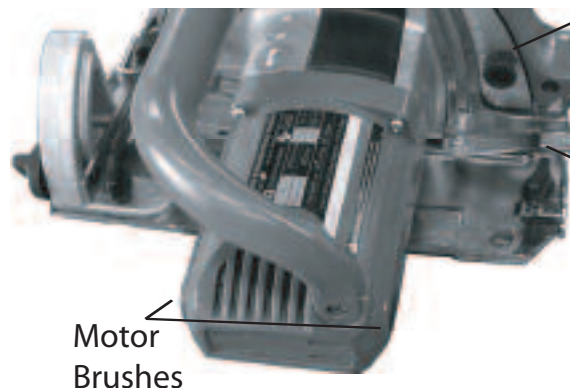



# TROUBLESHOOTING CHECKLIST

## S7 7-1/4" METAL CUTTER



ALWAYS DISCONNECT THE SAW FROM POWER SOURCE BEFORE TROUBLESHOOTING.

### 1. Machine will not turn on

- Inspect power cord for damage. Check continuity. Replace if needed. (PN SMS7-61)
- Inspect brushes for excessive wear. Replace if needed. (PN SMS7-2) (2)
- Do not exceed 30 minutes run time without cool down of saw.
- Check trigger switch for continuity. Replace if needed. (PN SMS7-62)

### 2. Losing Power

- Inspect brushes and replace if needed. (PN SMS7-2) (2)
- Extension cord too long. Limit cord length to 50' or less.
- Extension cord too thin. Use 12 AWG or larger.

### 3. Blade Guard Sticks

- Remove guard and remove any foreign material. Wipe any excess material from guard & face plate. Guard must move freely. Use light grease on mating contact surfaces to aid in movement.
- Check guard return spring for sufficient tension. Replace if spring is weak. (PN SMS7-34)
- Check guard for distortion. Replace if distorted or damaged. (PN SMS7-35)

### 4. Blade Spins on Spindle

- Check for proper tightness and installation. Inspect inner blade flange (PN SMS7-37) and outer blade flange (PN SMS7-39) for wear or damage. Replace if wear is excessive.
- Check flange mating surfaces for flatness. Replace if excessive distortion exists.
- Check to ensure flat washer is present between bolt head and outer blade drive flange.

### 5. Low Blade Life/Teeth Chipping

- Wrong blade for the type of material.
  - SM-BLL-0725 for mild steel up to 5/16" solid.
  - SM-BLL-0725-AL for aluminum up to 3/8" solid.
  - SM-BLL-0725-SS for stainless steel up to 1/4" solid.
  - SM-BLL-0725-TS for thin steel less than 1/4" solid.
- Aggressive contact with blade into material. The blade must be allowed to do the work.
- Too much vibration due to insufficient clamping, worn or bent blade, or worn parts (see "Saw Vibrates" below).

### 6. Saw Vibrates

- Check blade for tightness.
- Inspect inner blade flange (PN SMS7-37) and outer blade drive flange (PN SMS7-39) for wear or damage. Replace if needed.
- Check to ensure work is properly clamped. Both primary and cut-off piece can cause vibration.
- Check bevel lock and depth lock for tightness. (PN SMS7-91, SMS7-84, SMS7-76)
- Check blade teeth for missing carbide, bends or cracks.

### 7. Laser Won't Track

- Adjust Laser alignment screw (PN SMS7-67) with laser turned on.

# SPECIFICATIONS

## Model S7

### DIMENSIONS AND SPECIFICATIONS

Height	12.5"
Width	10.5"
Length	16.5"
Weight	14.3 lbs.
Motor	120V - 1500W 50~60 Hz / 3500 RPM
Blade Arbor	20 mm
Blade Diameter	7 1/4"
Depth of Cut/Pipe or Angle (maximum)	2 3/8"
Depth of Cut/Plate or Bar (maximum)	5/16" Mild Steel 3/8" Aluminum 1/4" Stainless Steel <1/4" Thin Steel
Case Dimensions	13.5" H 11.5" W 20" L

# ACCESSORIES

### Saw Blades

Application	Part #
For cutting mild steel to 5/16"	SM-BLL-0725
For cutting thin steel to 1/4"	SM-BLL-0725-TS
For cutting aluminum to 3/8"	SM-BLL-0725-AL
For cutting stainless steel to 1/4"	SM-BLL-0725-SS

YOUR STEELMAX DISTRIBUTOR

801 W, Mineral Ave. Suite 103  
Littleton, CO 80120

Phone 303.690.9146 or Fax · 303.690.9172

email · sales@steelmax.com / web · steelmax.com

LIT-102SM  
©1/06

# PRODUCT REGISTRATION AND WARRANTY CARD

Thank you for purchasing a Steelmax® product!  
Please fill out this form and return promptly so that we may register your purchase.

Model# \_\_\_\_\_ Serial # \_\_\_\_\_ Date of Purchase \_\_\_\_\_

STEELMAX  
801 W. Mineral Ave, STE 103.  
Littleton, CO 80120  
PHONE 303.690.9146  
FAX 303.690.9172  
STEELMAX.COM

*Please detach and retain this top portion for your records.*

Mr.  Mrs.  Ms.  Miss

First Name		Last Name	
Company Name			
Street Address			
City		State	Zip
Phone Number		Fax Number	E-mail Address
May we contact you by: Mail <input type="checkbox"/> Fax <input type="checkbox"/> E-mail Address <input type="checkbox"/>			
Model		Serial#	Date of Purchase

Where did you purchased your SteelMax product from

What are the top two reasons that influenced your purchase of this Steelmax brand product?

- |   |   |                                       |
|---|---|---------------------------------------|
| Reputation <input type="checkbox"/>       | Value for price <input type="checkbox"/>        | Web site <input type="checkbox"/>     |
| Safety features <input type="checkbox"/>  | Magazine ad <input type="checkbox"/>            | Availability <input type="checkbox"/> |
| Recommendation <input type="checkbox"/>   | Reputation of retailer <input type="checkbox"/> | Other <input type="checkbox"/>        |
| Style/Appearance <input type="checkbox"/> | Quality/Durability <input type="checkbox"/>     |                                       |

In your opinion, what is the BEST industry publication you regularly read? \_\_\_\_\_

Is this: A first time purchase?  An additional unit?  A replacement unit?  For which brand? \_\_\_\_\_

Additional comments: \_\_\_\_\_

Thank You! We value your answers and input.  
 **Yes, put me on the Steelmax email list for special offers.**