



The tools of innovation.

OPERATOR'S MANUAL

BM-18

BEVELING MACHINE

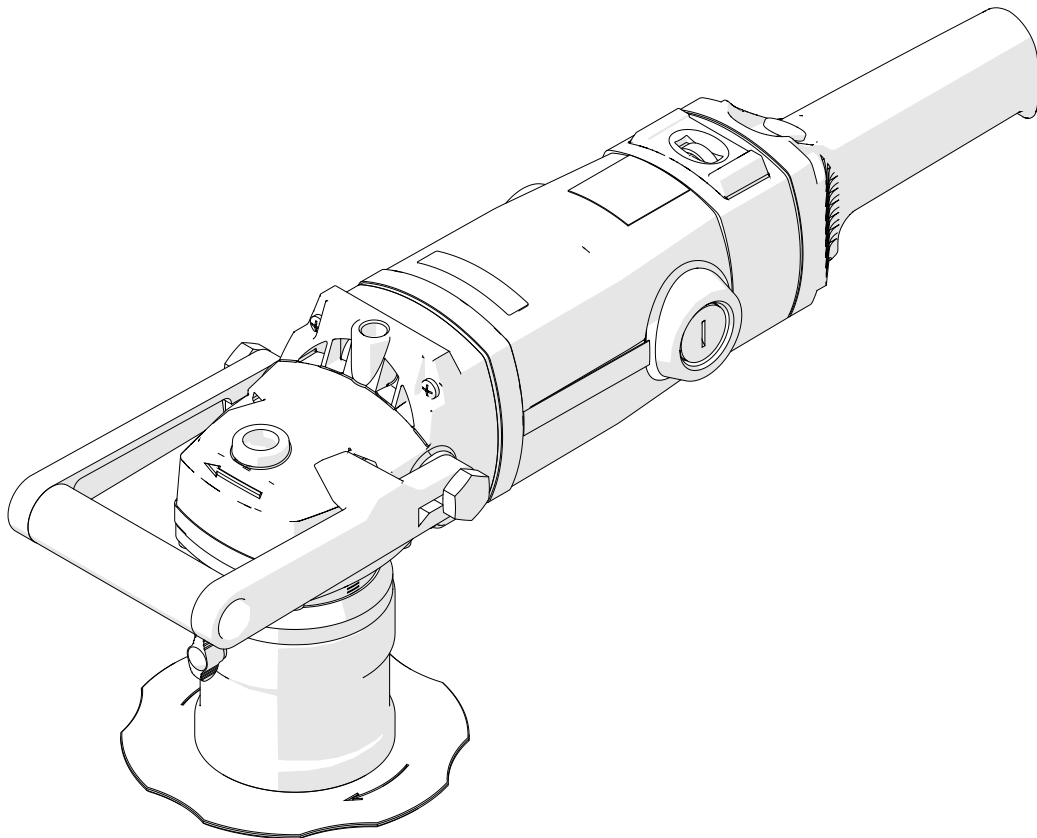

801 W. Mineral Ave. Suite 103 Littleton, CO 80120

1- 303 - 690 - 9146, FAX 303 - 690 - 9172

www.steelmax.com sales@steelmax.com

Contents

1. GENERAL INFORMATION	3
1.1. Application	3
1.2. Technical data	3
1.3. Equipment included	4
1.4. Dimensions	4
1.5. Design.....	5
2. SAFETY PRECAUTIONS	6
3. SYMBOLS	8
4. STARTUP AND OPERATION.....	9
4.1. Removing and installing the milling head	9
4.2. Adjusting the bevel width	11
4.3. Adjusting the guide for beveling with radius	12
4.4. Preparing	12
4.5. Operating	13
4.6. Replacing the cutting inserts.....	14
4.7. Replacing the roller.....	15
4.7.1. Replacing the beveling roller.....	15
4.7.2. Replacing the radius roller	16
4.8. Replacing the brushes	17
5. ACCESSORIES	18
5.1. Pipe attachment.....	18
5.2. Sticker against scratches.....	21
5.3. Worktable fixture.....	21
5.4. Radius insert positioner	25
5.5. Milling tools	26
6. SPARE AND WEARING PARTS	27
7. EXPLODED VIEWS AND PARTS LIST	28
8. DECLARATION OF CONFORMITY	36
9. ENVIRONMENTAL PROTECTION.....	37
10. WARRANTY CARD	38

1. GENERAL INFORMATION

1.1. Application

The BM-18 is a beveling machine designed to bevel plates and pipes made of steel, aluminum alloys, brass, or plastics.

Depending on the milling head, the machine allows you to bevel at the angle of 22.5°, 30°, 37.5°, 45°, 50°, 55°, or 60°. The minimum workpiece thickness is 0.08" (2 mm). The maximum bevel width is 11/16" (18 mm). A radius milling head allows you to bevel with a radius of 2, 3, 4, or 5 mm. The minimum diameter of a hole to be machined is 1.57" (40 mm).

An optional attachment allows you to bevel pipes and a sticker protects aluminum workpieces from scratches. A worktable fixture allows you to bevel flat bars.

The machine is designed for professional use only.

1.2. Technical data

Voltage	1~ 220–240 V, 50–60 Hz 1~ 110–120 V, 50–60 Hz
Power	2200 W
Rotational speed with no load	1800–5850 rpm
Protection level	IP 20
Protection class	II
Maximum bevel width (<i>b</i>)	11/16" (18 mm, Fig. 1)
Bevel angle (β , depends on the milling head)	22.5°, 30°, 37.5°, 45°, 50°, 55°, 60 (Fig. 1)
Minimum workpiece thickness (beveling)	0.08" (2 mm)
Minimum workpiece thickness (radius beveling)	0.27" (7 mm)
Minimum hole diameter	1.57" (40 mm)
Edge radius	2 mm, 3 mm, 4 mm, 5 mm (Fig. 1)
Noise level	More than 70 dB
Vibration level	2.3 m/s ² (7.5 ft/s ²) Machine harmful for health. Take periodic breaks during work.
Required ambient temperature	0–40°C (32–104°F)
Weight (without milling head)	22 lbs. (10 kg)

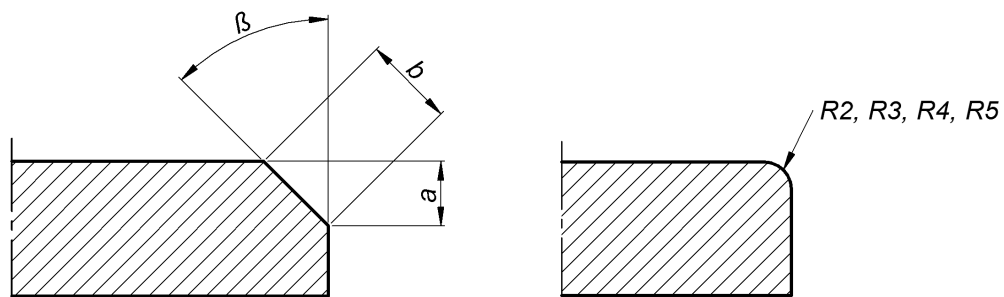
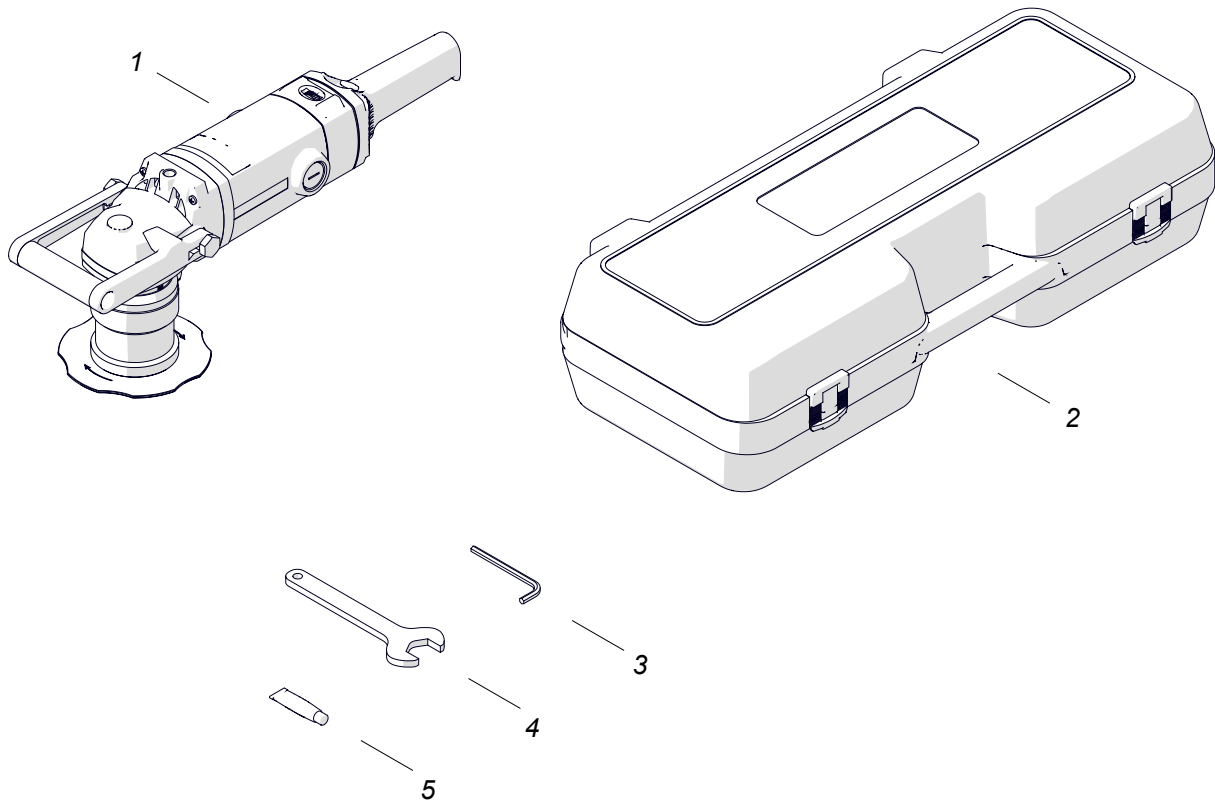

Fig. 1. Bevel dimensions

1.3. Equipment included



1	Beveling machine (without milling head)	1 unit
2	Plastic box	1 unit
3	6 mm hex wrench	1 unit
4	32 mm flat wrench	1 unit
5	Grease for screws (5 g, 0.17 oz)	1 unit
-	Operator's Manual	1 unit

1.4. Dimensions

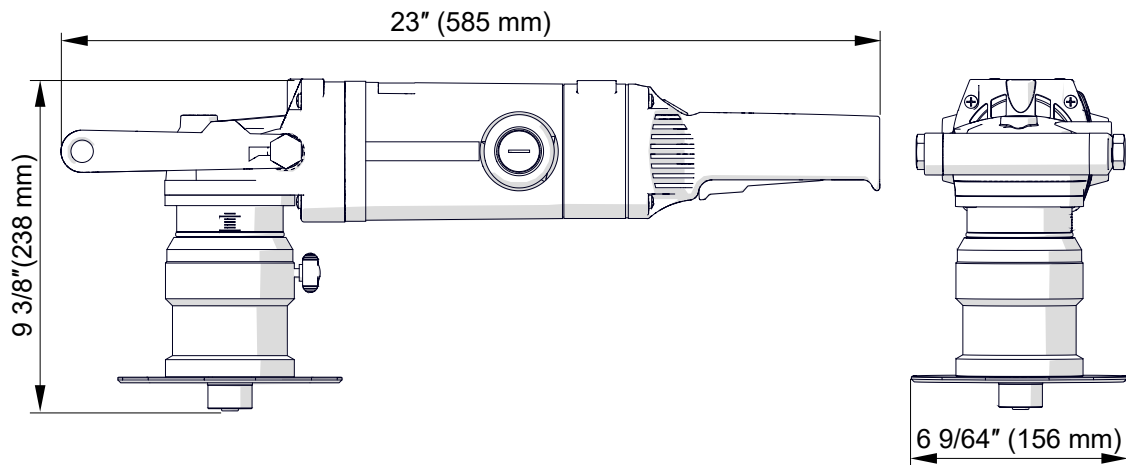

1.5. Design

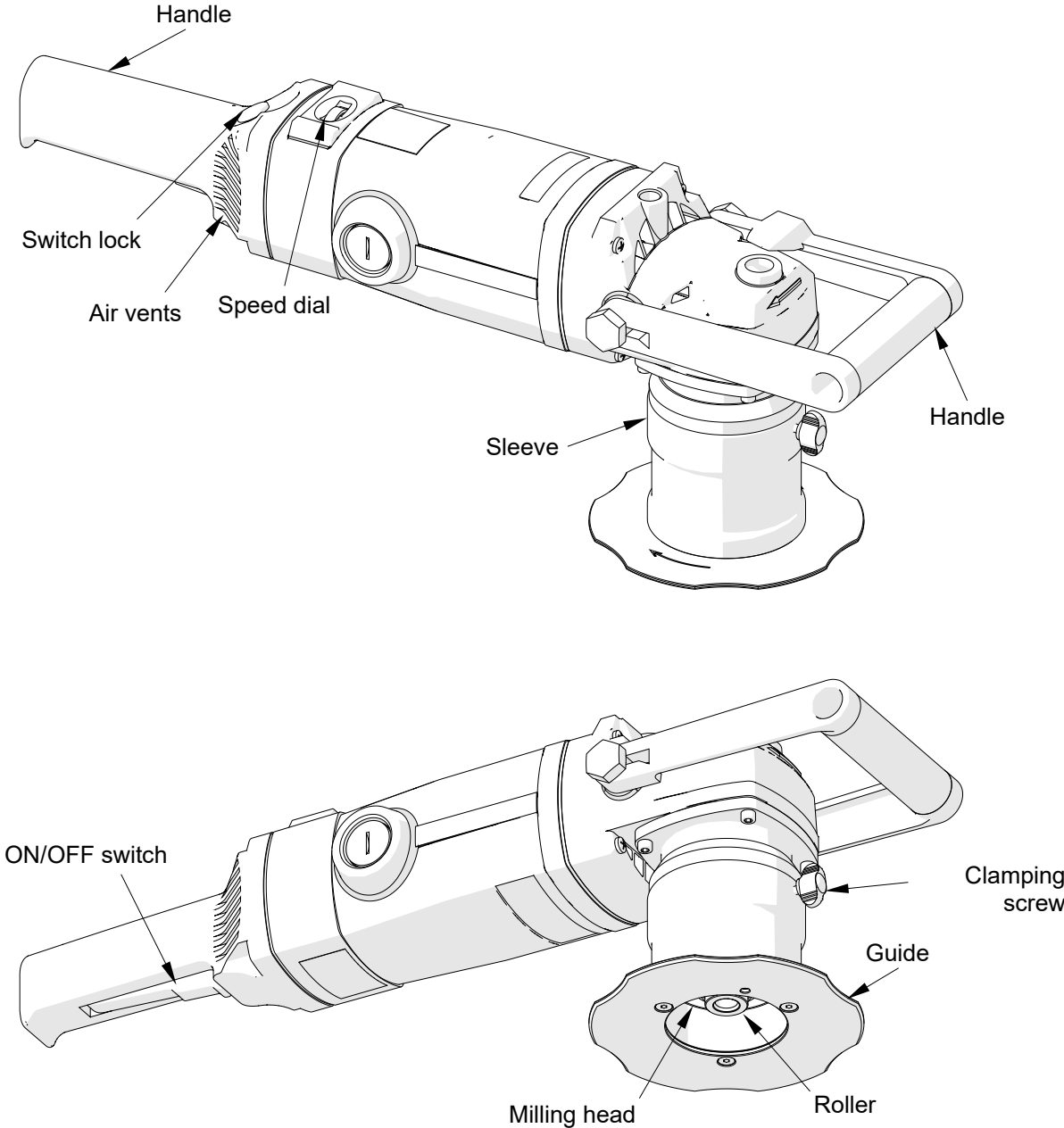

2. SAFETY PRECAUTIONS

1. Before using, read this Operator's Manual and complete a training in occupational safety and health.
2. Use only in applications specified in this Operator's Manual.
3. Make sure that the machine has all parts and they are genuine and not damaged.
4. Make sure that the specifications of the power source are the same as those specified on the rating plate.
5. Do not carry the machine by the cord and do not pull the cord. This can cause damage and electric shock.
6. Keep untrained bystanders away from the machine.
7. Before each use, ensure the correct condition of the machine, power source, power cord, plug, control parts, and tools.
8. Before each use, make sure that no part is cracked or loose. Make sure to maintain correct conditions that can have an effect on the operation of the machine.
9. Keep the machine dry. Do not expose the machine to rain, snow, or frost.
10. Keep the work area well-lit, clean, and free of obstacles.
11. Do not use near flammable materials, or in explosive environments.
12. Use only tools specified in this Operator's Manual.
13. Do not use tools that are dull or damaged.
14. Make sure that the cutting inserts and the milling head are correctly attached. Remove wrenches from the work area before you connect the machine to the power source.
15. Do not use the machine so that the milling head points up.
16. If the cutting edge of an insert is worn, turn all inserts by 90° or 180°. If all the cutting edges are worn, install new inserts specified in this Operator's Manual.
17. Use eye and ear protection, non-skid footwear, and protective clothing. Do not use loose clothing.
18. Do not touch chips or moving parts. Do not let anything catch in moving parts.
19. After each use, clean the machine and the milling head with a dry cotton cloth and no chemical agents. Do not remove chips with bare hands.
20. Maintain the machine and install/remove parts and tools only after you unplug the machine from the power source.
21. Repair only in a service center appointed by the seller.

22. If the machine falls, is wet, or has any damage, stop the work and immediately send the machine to the service center for check and repair.
23. If you are not going to use the machine, remove it from the work area and keep it in a safe and dry place.
24. If you are not going to use the machine for an extended period, put anti-corrosion material on the steel parts.

3. SYMBOLS

Before using the machine, familiarize yourself with the following symbols (tab. 1).



Use eyes protection



Use hearing protection



Read the Operator's Manual



Warning against electric voltage

Tab. 1. Explanation of symbols

4. STARTUP AND OPERATION

4.1. Removing and installing the milling head

Unplug the power cord. To remove the milling head, continue in the following sequence.

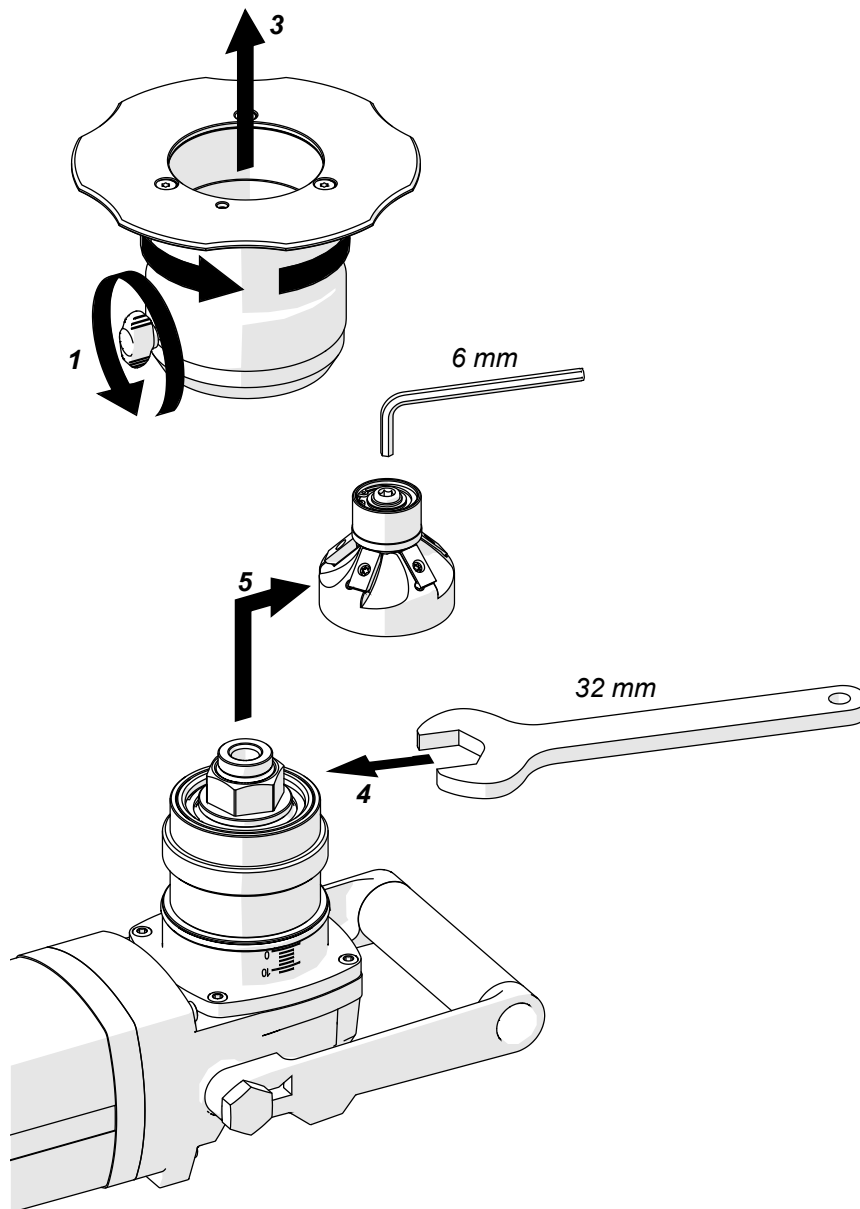

To install the milling head, remove the sleeve as shown before. Then, continue in the sequence that follows. Make sure that the milling head aligns with the spindle (3).

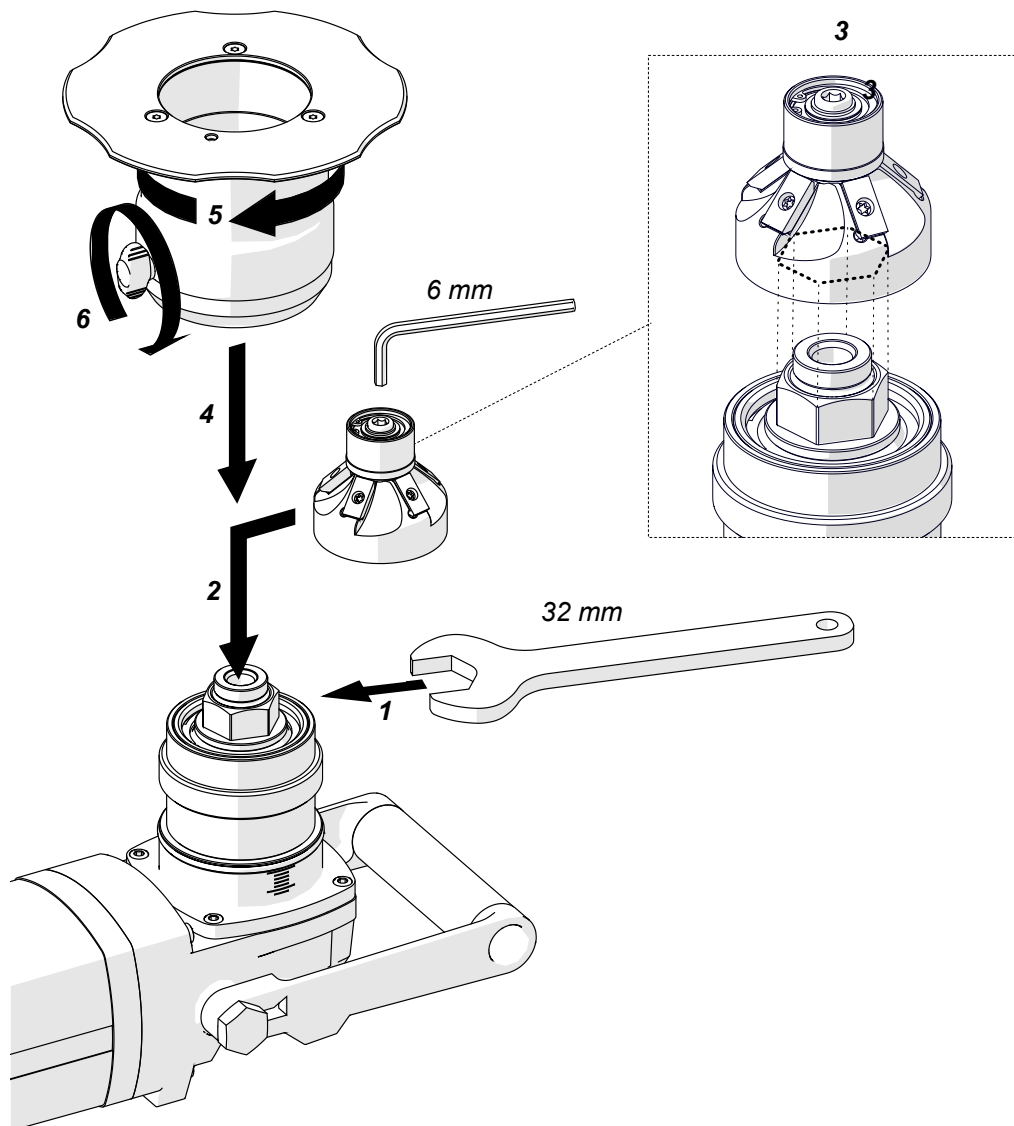

4.2. Adjusting the bevel width

Unplug the power cord. Loosen the screw (1) and turn the sleeve (2) so that the scale (3) shows the height 'a' related to the required width 'b'. Tighten the screw.

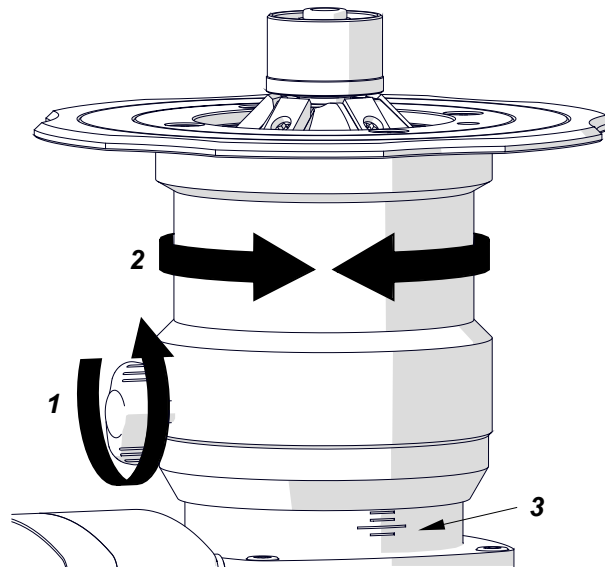

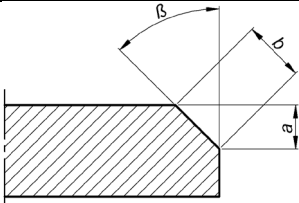
	Milling head						
	22.5°	30°	37.5°	45°	50°	55°	60°
Height 'a' [mm]	Width 'b' [mm]						
2	2.2	2.3	2.5	2.8	3.1	3.5	4.0
3	3.2	3.5	3.8	4.2	4.7	5.2	6.0
4	4.3	4.6	5.0	5.7	6.2	7.0	8.0
5	5.4	5.8	6.3	7.1	7.8	8.7	10.0
6	6.5	6.9	7.6	8.5	9.3	10.5	12.0
7	7.6	8.1	8.8	9.9	10.9	12.2	14.0
8	8.7	9.2	10.1	11.3	12.4	13.9	16.0
9	9.7	10.4	11.3	12.7	14.0	15.7	18.0
10	10.8	11.5	12.6	14.1	15.6	17.4	
11	11.9	12.7	13.9	15.6	17.1	18.0	
12	13.0	13.9	15.1	17.0	18.0		
13	14.1	15.0	16.4	18.0			
14	15.2	16.2	17.6				

Tab. 1. Relation between the bevel width and bevel height for the available milling heads

4.3. Adjusting the guide for beveling with radius

Unplug the power cord. Loosen the clamping screw and turn the sleeve to align the surface (1) with the end of the cutting edge (2). You can also use an optional radius insert positioner to set the guide correctly. Tighten the clamping screw. Bevel a test edge and if necessary adjust the position of the guide again.

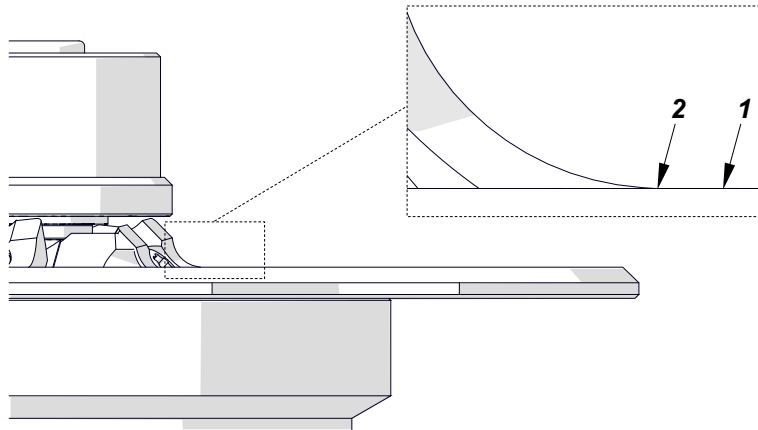

4.4. Preparing

Install a milling head with the cutting inserts, and set the required bevel width. Then, use the speed dial to set the speed that matches the type of the workpiece.

Material type	Rotational speed
Aluminum, brass, plastics	Setting 6 (5850 rpm)
Structural steel of standard quality, quality steel	Settings 3–5 (3100–4500 rpm)

The speed dial allows continuous control of the rotational speed in the range of 1800–5850 rpm.

Setting	1	2	3	4	5	6
Speed	1800 rpm	2400 rpm	3100 rpm	3800 rpm	4500 rpm	5850 rpm

To machine structural steel of standard quality or quality steel, set the speed to 4 and decrease the speed if much sparking occurs.

4.5. Operating

Connect the machine to the power source. Put the machine on the left as shown in the figure. Make sure that the workpiece is stable.

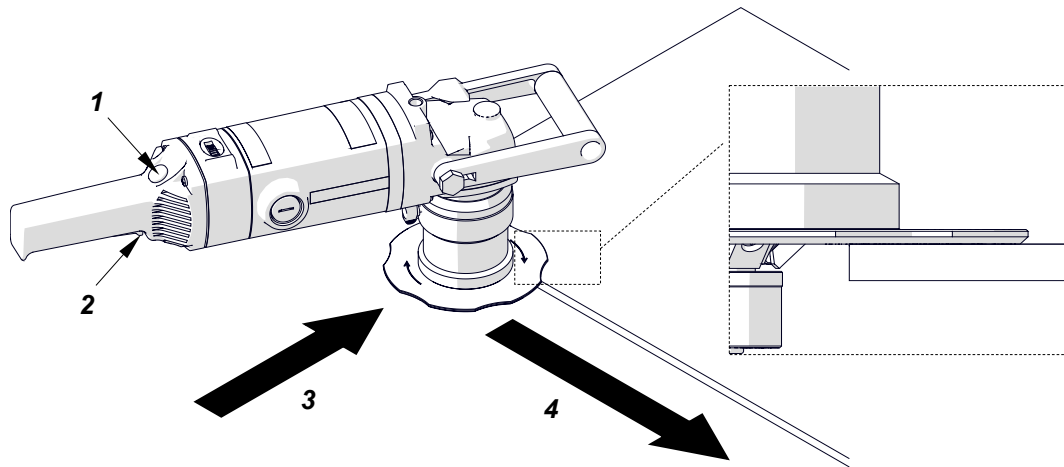

To start the motor, press and hold the switch lock (1) and the ON/OFF switch (2), and then release the lock. Wait until the speed is at the required value. With two hands press the machine to the workpiece. Then, slowly move the machine to the edge (3) until the tool starts cutting. Move the machine from left to right (4).

Start with making small widths (3–4 mm, 0.12–0.16") and increase them with experience. Bevel in at least two passes. Set the bevel width to a value that will allow the feed of 1 m/min (3 ft/min) without using too much force.

If an overload occurs, the motor stops. This can happen when the bevel width is too large for the hardness of material or when the cutting inserts are dull. Thus, to prevent overload, machine hard materials in multiple passes and replace the inserts before they become dull. Also, take periodic breaks during work and keep the air vents unclogged. This prevents motor overheating and damage to the windings.

After the work is finished, release the ON/OFF switch to turn off the motor. Then, wait until the rotation stops and unplug the power cord.

Clean the machine with a dry cotton cloth and no chemical agents.

4.6. Replacing the cutting inserts

Unplug the power cord. Loosen the screw (1) and turn the sleeve (2) to lower it as far as possible and get access to the milling head. Use the T15 torx screwdriver to remove the cutting inserts (3, 4). Clean the sockets.

To change the cutting edge, remove the inserts and turn them by 90° or 180°. Then, push them to the sockets and tighten. If all the cutting edges are worn, install new inserts. Make sure that the bottom of each insert is in full contact with the socket (5).

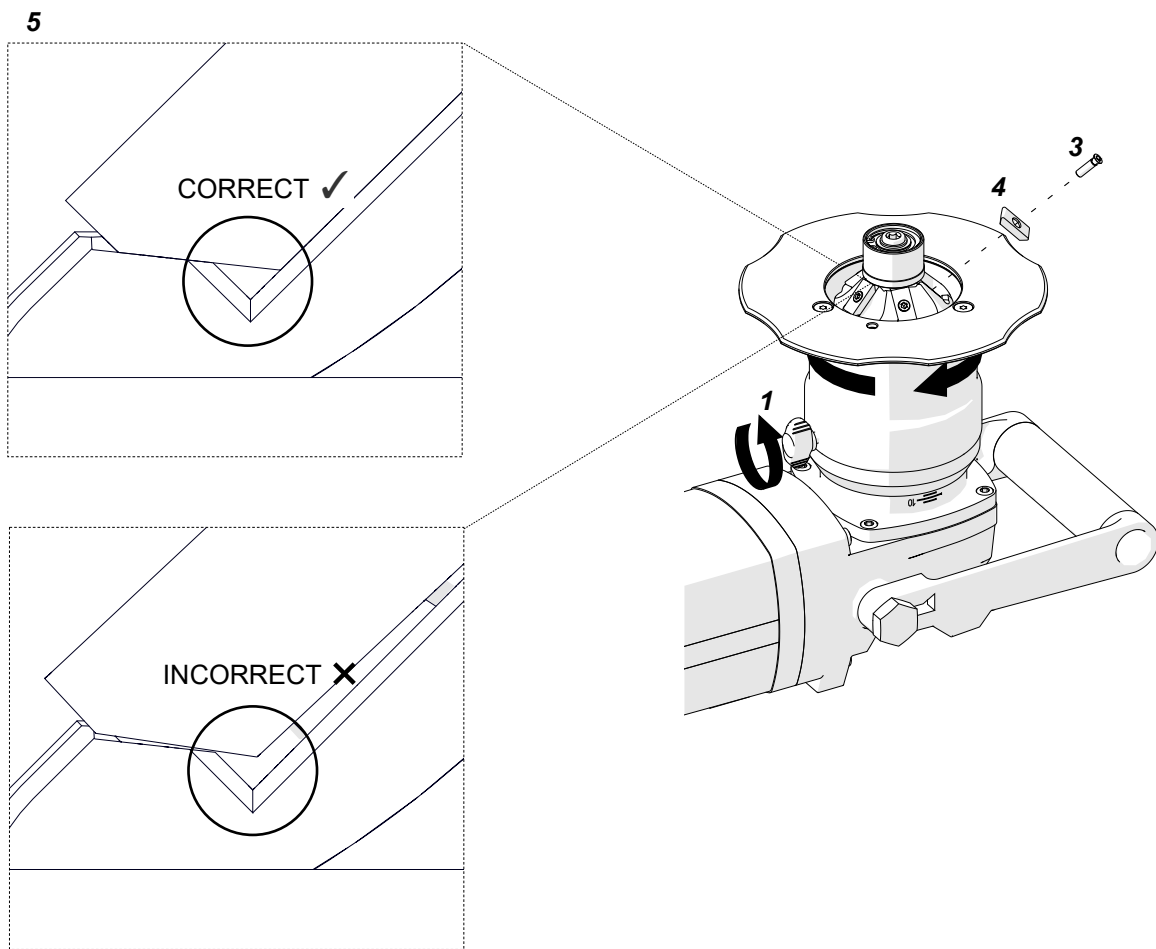

Every week clean the threads of the mounting screws for inserts and put the supplied grease on the threads.

4.7. Replacing the roller

4.7.1. Replacing the beveling roller

Unplug the power cord. Remove the circlip and the roller.

To install the roller, use such a number of 1 mm, 0.5 mm, and 0.2 mm washers to set the gap to 0.2–0.6 mm between the roller and the cutting inserts. The number of washers needed depends on the milling head. Put all unused washers between the circlip and the roller.

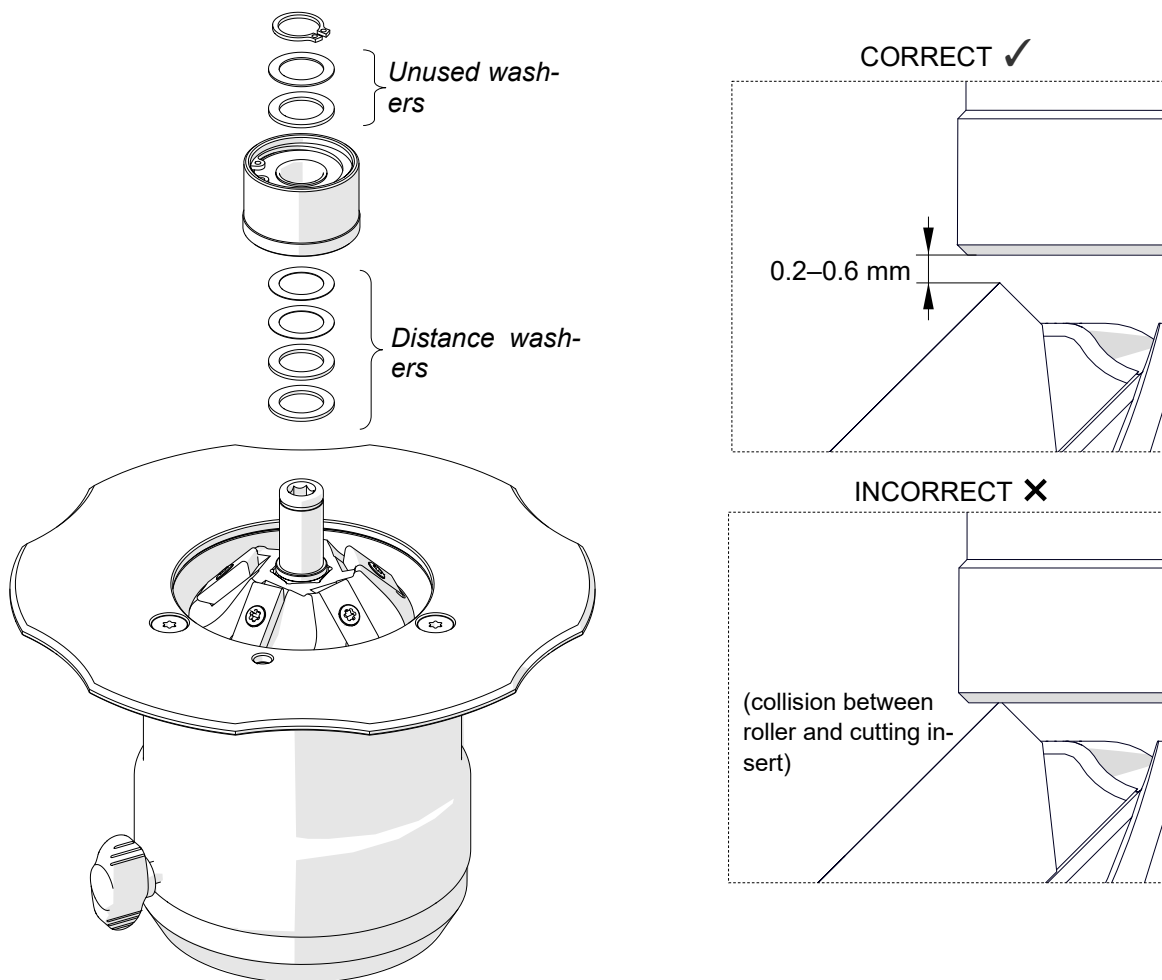

4.7.2. Replacing the radius roller

Unplug the power cord. Remove the circlip and the roller.

To install the roller, use such a number of 1 mm, 0.5 mm, and 0.2 mm washers to keep a small gap between the roller and the cutting inserts. Make sure that the roller turns freely.

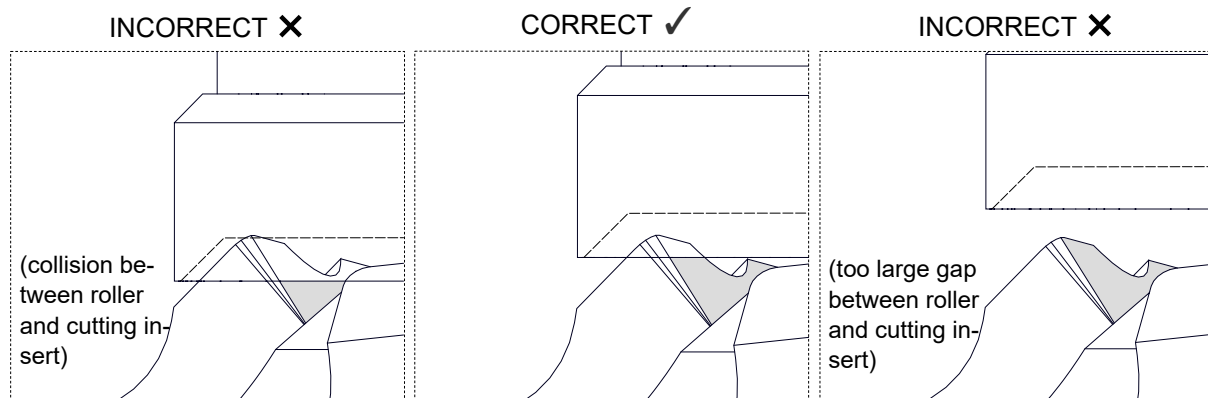

4.8. Replacing the brushes

Every 200 work hours, check the condition of the carbon brushes. To do this, unplug the power cord, and then remove the cap and the brush. If the brush is shorter than 10 mm (0.4"), replace the two brushes with new ones.

Install in reverse sequence. Then, let the motor operate with no load for 20 minutes.

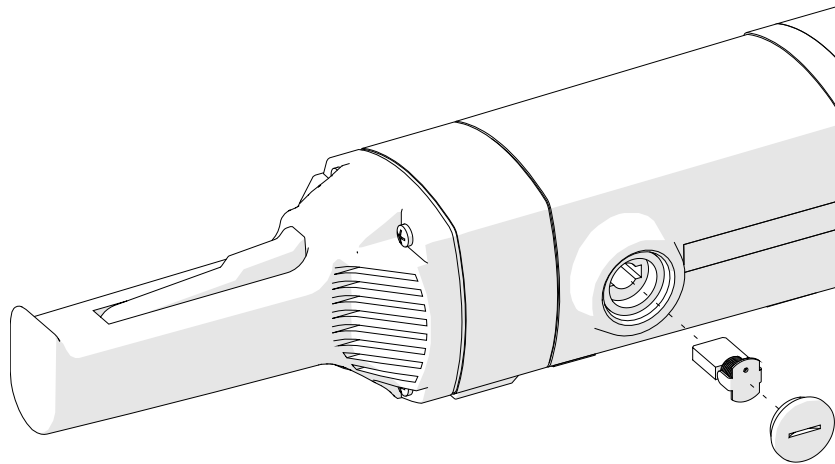

5. ACCESSORIES

5.1. Pipe attachment

Allows for external beveling of pipes with diameters of at least 150 mm (5 29/32") and internal beveling of pipes with diameters of at least 110 mm (4 21/64").

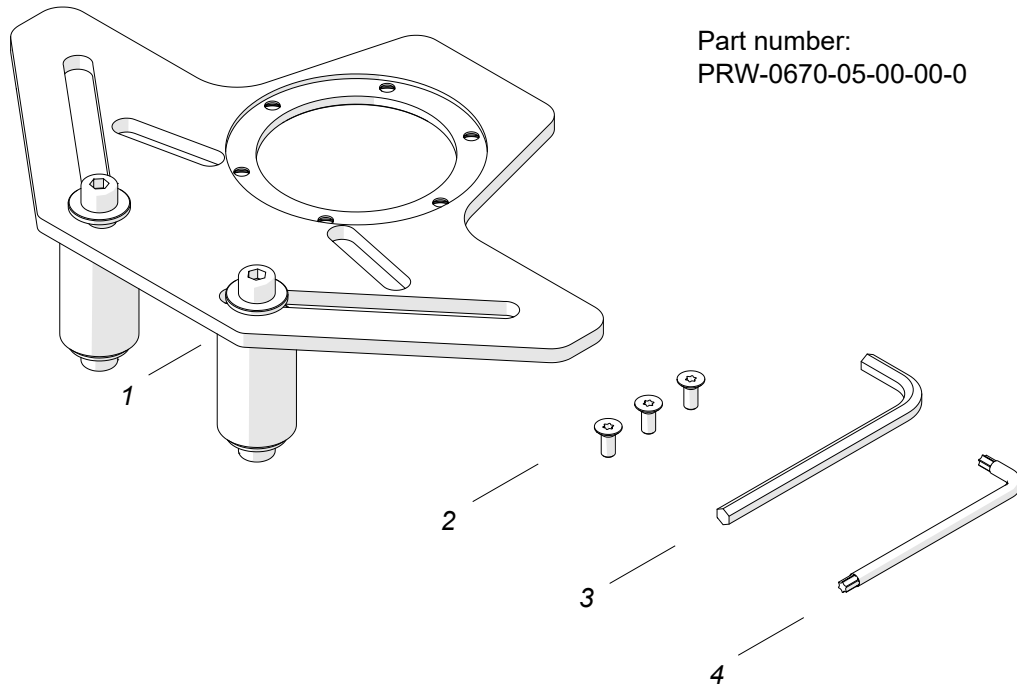

1	Pipe attachment	1 unit
2	M5x12 screw	3 units
3	6 mm hex wrench	1 unit
4	T25 torx wrench	1 unit

To install, unplug the power cord.

Use heat to increase the temperature of the screws.

Use the T25 torx wrench to remove the standard guide, and then install the pipe attachment.

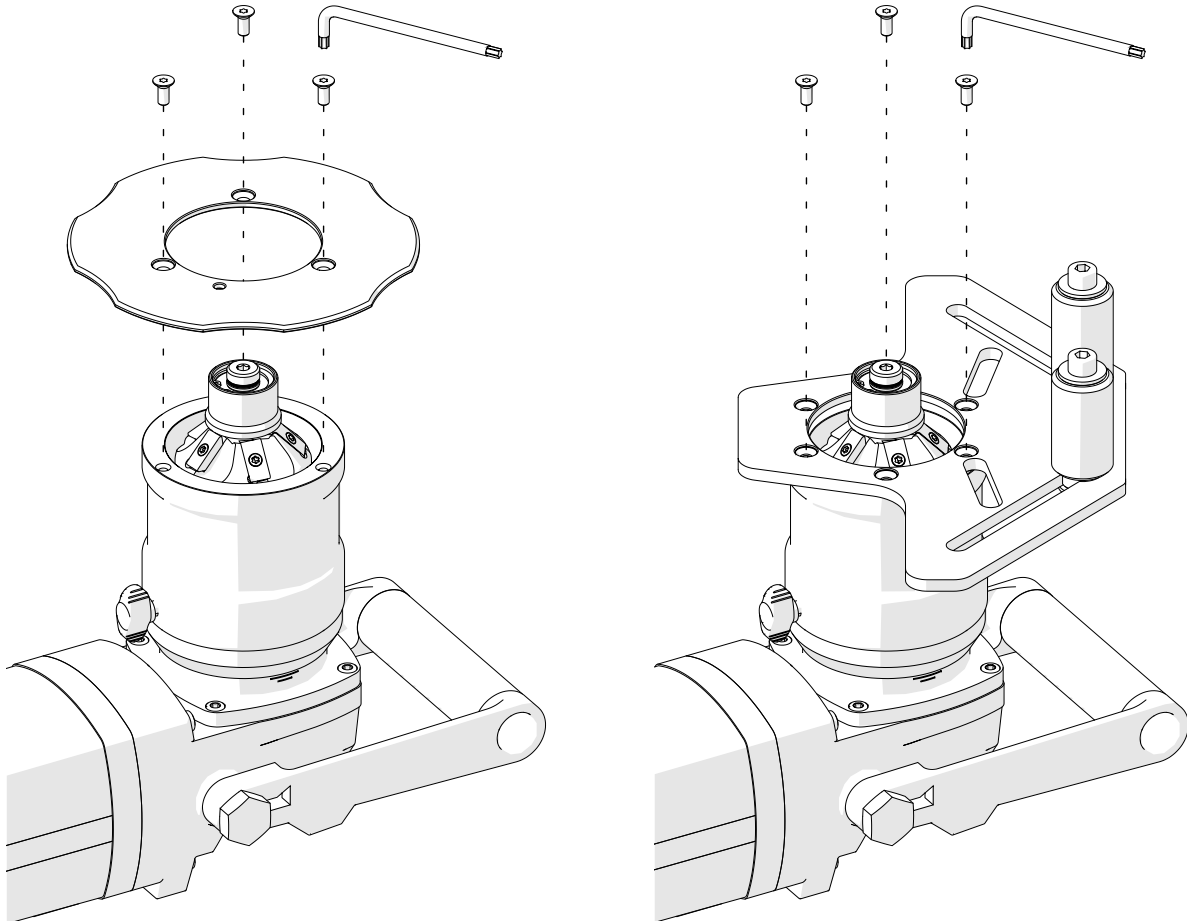

Turn the sleeve to set '0' on the scale (1). Use the 6 mm hex wrench to loosen the rollers (2) and move them away from each other as far as possible. Put the pipe vertically and put the machine onto the pipe. Press the roller (3) to the pipe and move the rollers (4) equally to the pipe. Tighten the rollers in this position. Next, move the machine from the pipe and set the required parameters (5). Then, start the machine, slowly move it to the pipe, and bevel in the direction (6).

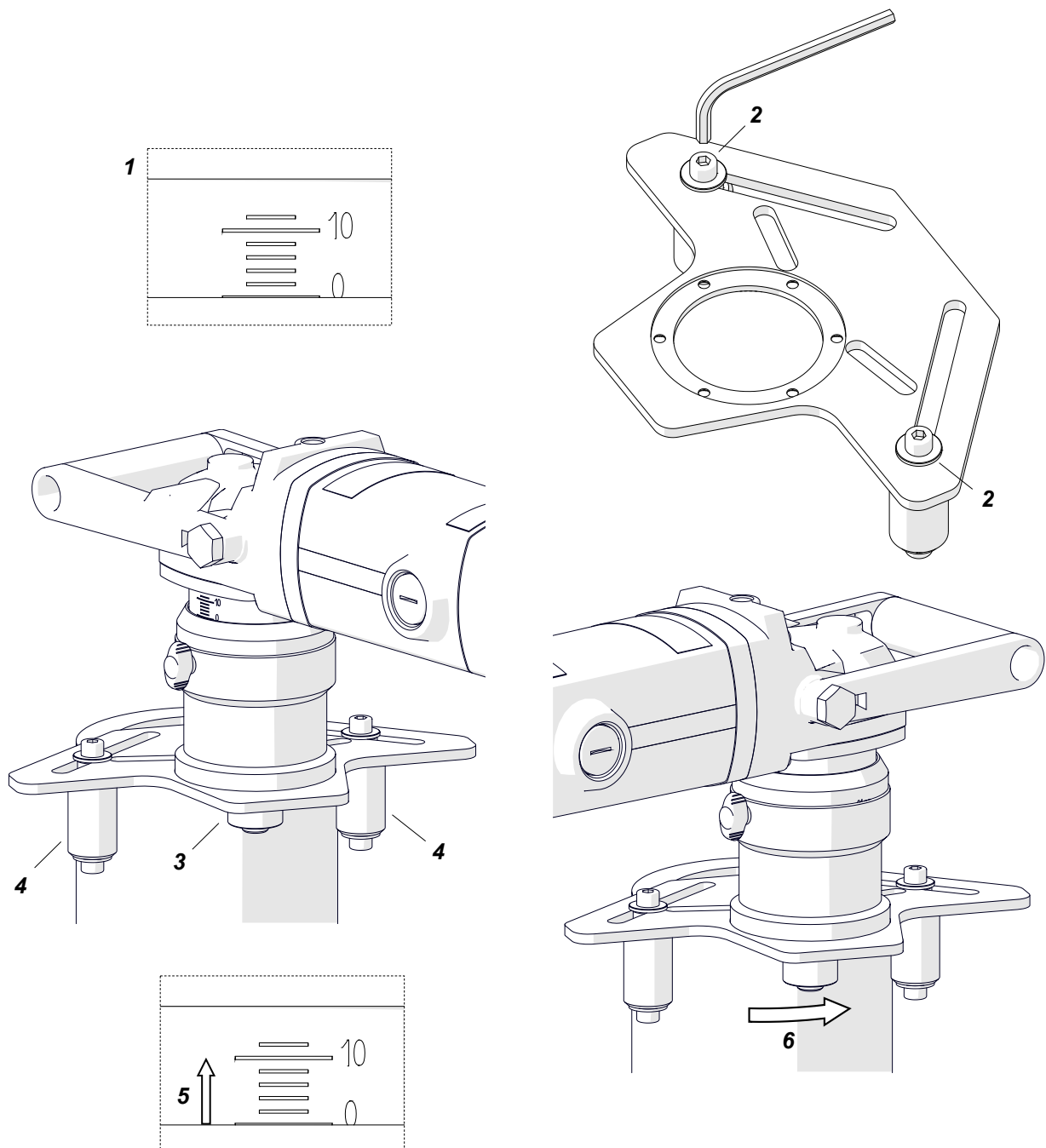

5.2. Sticker against scratches

Self-adhesive guide sticker protects aluminum workpieces from scratches. After you remove the sticker, clean the guide with petroleum ether.

Part number:
NKL-0509-05-00-00-0

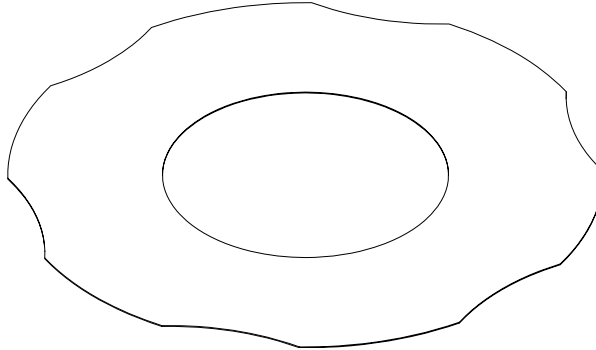

5.3. Worktable fixture

Allows you to bevel flat bars with cross section of at least 15×25 mm (19/32" × 1") and length of at least 400 mm (16"). The maximum width of the flat bar is 100 mm (4") and the maximum height is 65 mm (2 9/16"). The maximum bevel width is 14 mm (35/64").

Part number:
ZBD-0509-12-00-00-0
(includes 5 mm hex wrench)

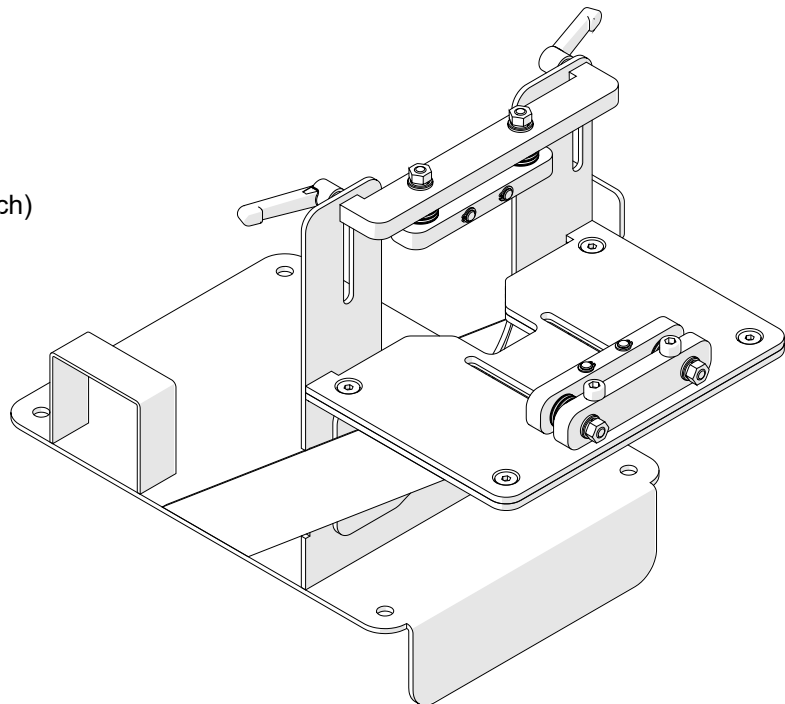

Install the worktable fixture by using the holes in the base (1). Then, remove the levers and the vertical clamp (2). Unplug the power cord and turn the sleeve to set '0' on the scale. Next, put the machine with a beveling milling head into the fixture (3) so that the motor is on the support (4).

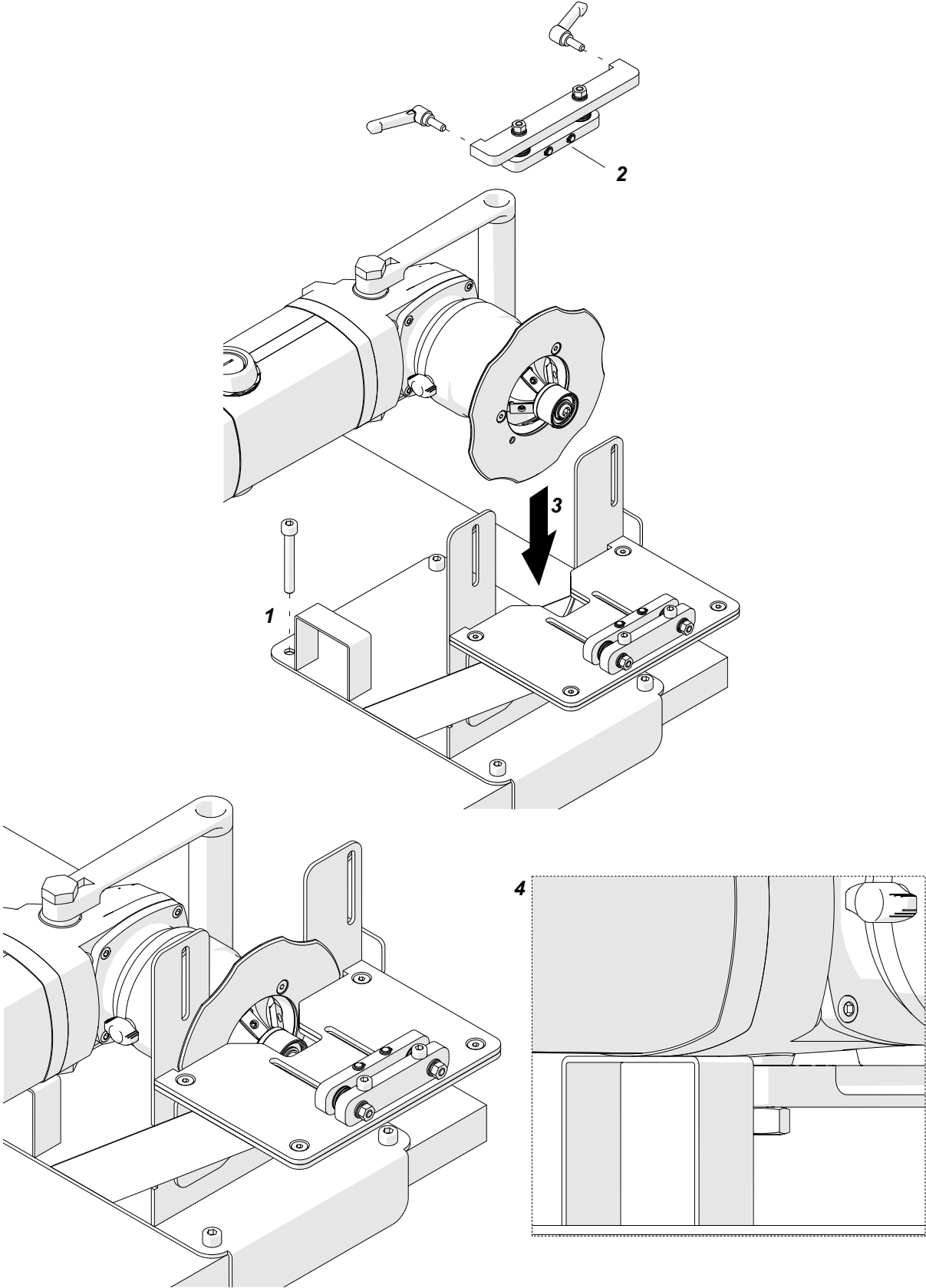

Use the 5 mm hex wrench to loosen the horizontal clamp (1), and then put the workpiece (2) so that it makes contact with the guide (3). Move the horizontal clamp to the workpiece (4) and tighten the screws in this position (5).

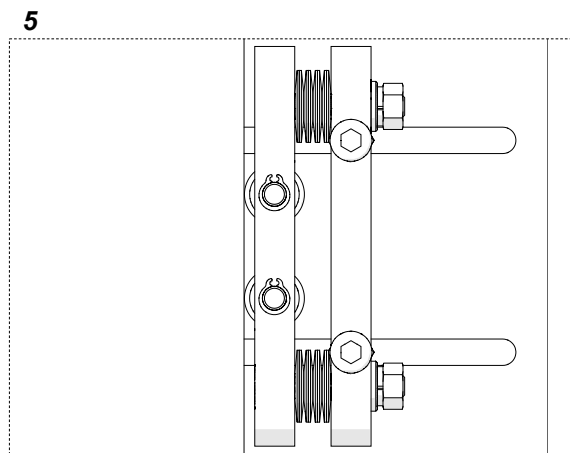
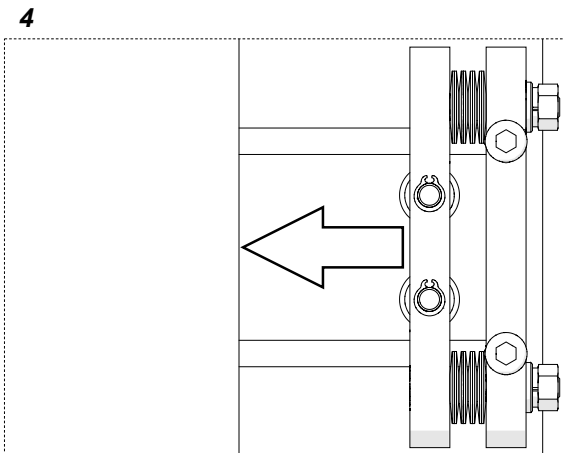
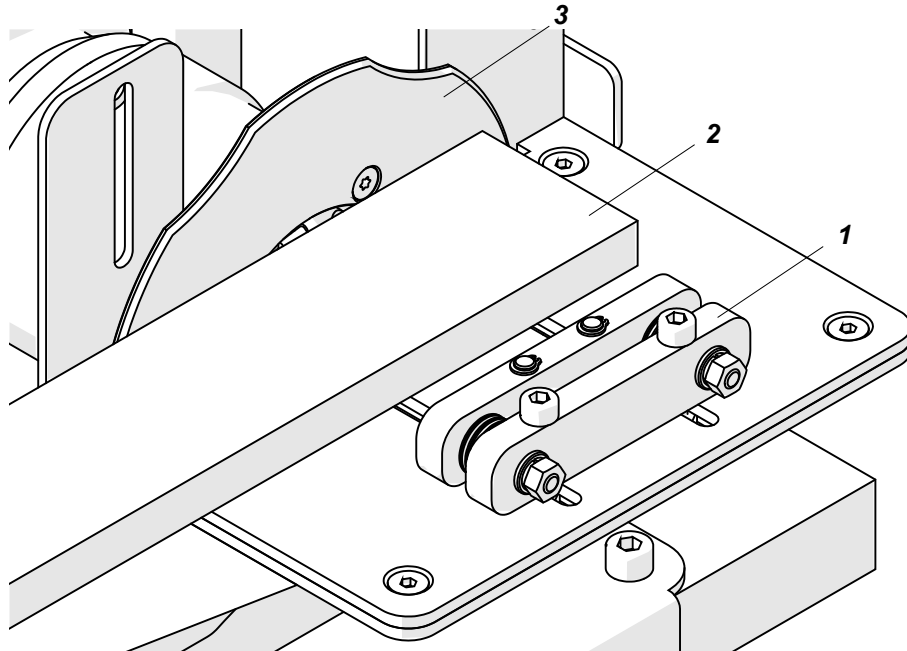

Lightly tighten the levers (1) to install the vertical clamp (2). Move the clamp to the workpiece (3) and tighten the levers in this position (4). Next, remove the workpiece and set the required bevel parameters. Then, use the 5 mm hex wrench to tighten the screws (5) to attach the machine.

Start the machine and set the required rotational speed. Then, put the workpiece on the left and bevel in the direction (6).

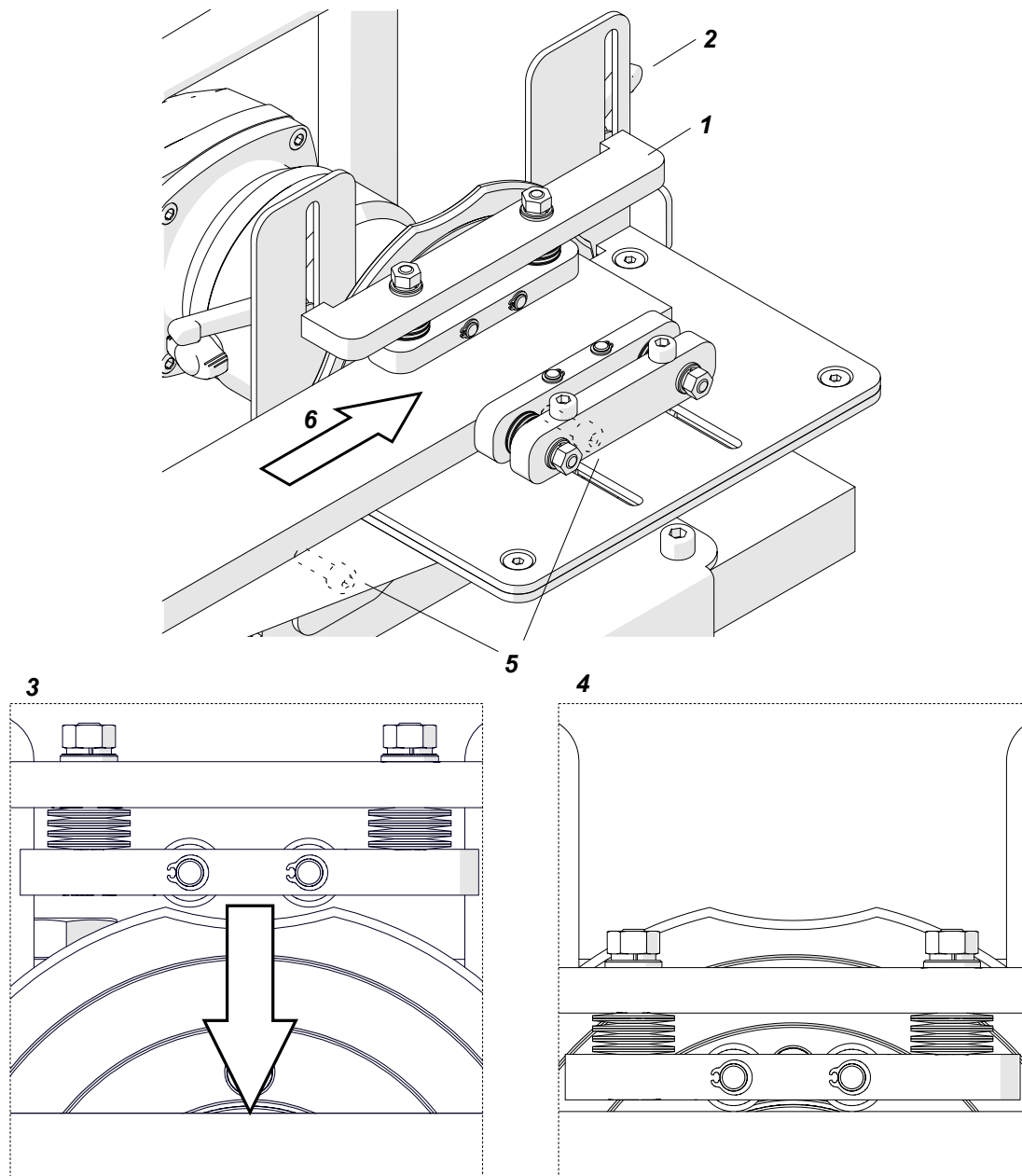

5.4. Radius insert positioner

Allows you to set the guide correctly for beveling with a radius of 2, 3, 4, or 5 mm.

Part number:
UST-0509-16-00-00-0

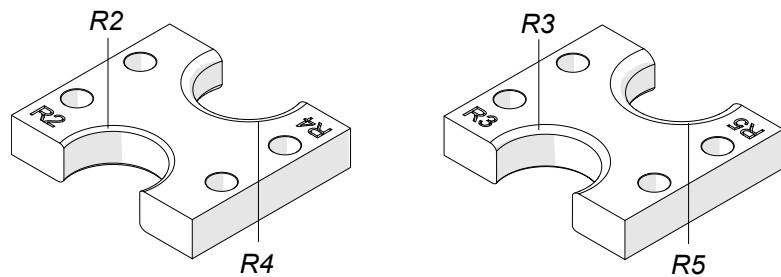

Unplug the power cord and lower the sleeve to get access to the cutting inserts. Put the positioner from the top (1) so that the edge marked with a given radius aligns with the edges of three cutting inserts with the same radius (2). Turn the sleeve (3) until the guide is in contact with the positioner (4).

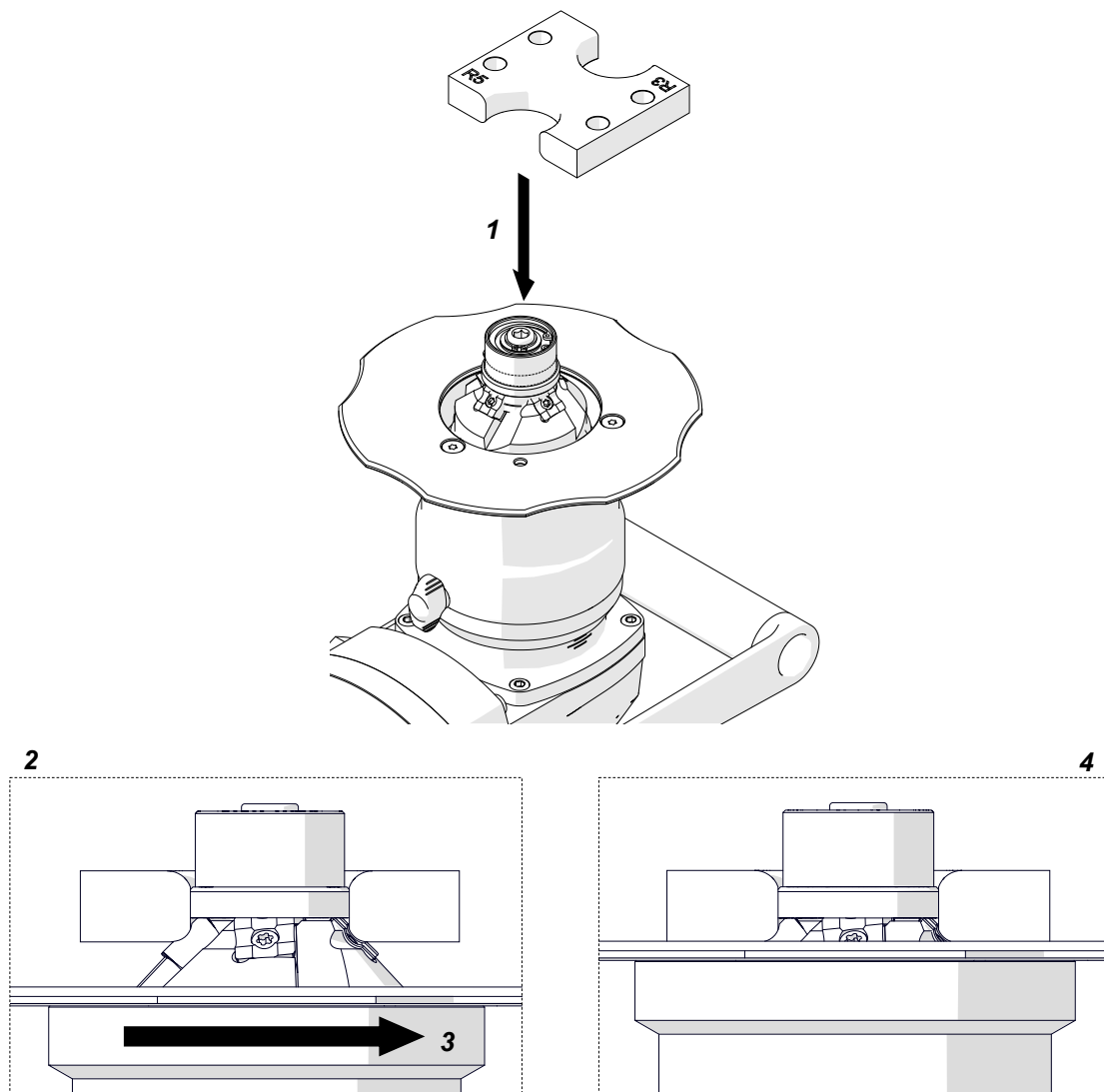

5.5. Milling tools

Part number	Part name
GLW-0640-30-01-00-0	Beveling milling head 22.5°
GLW-0640-30-02-00-0	Beveling milling head 30°
GLW-0640-30-03-00-0	Beveling milling head 37.5°
GLW-0640-30-04-00-0	Beveling milling head 45°
GLW-0640-30-05-00-0	Beveling milling head 50°
GLW-0640-30-06-00-0	Beveling milling head 55°
GLW-0640-30-07-00-0	Beveling milling head 60°
PLY-000395	Beveling insert for steel (5 required, sold per 10 in a set)
PLY-000195	Beveling insert for aluminum (5 required, sold per 10 in a set)
SRB-000290	Mounting screw for beveling insert
GLW-0640-30-34-00-0	Radius milling head
PLY-000360	Radius insert R2 (4 required, sold per 10 in a set)
PLY-000159	Radius insert R3 (4 required, sold per 10 in a set)
PLY-000160	Radius insert R4 (4 required, sold per 10 in a set)
PLY-000161	Radius insert R5 (4 required, sold per 10 in a set)
SRB-000289	Mounting screw for radius insert

6. SPARE AND WEARING PARTS

Part number	Part name
SCZ-000031	Carbon brush for 110 V
SCZ-000030	Carbon brush for 230 V
KLC-0509-13-00-00-0	32 mm flat wrench
KLC-000009	6 mm hex wrench
KLC-000028	T15 torx screwdriver
SMR-000005	Grease for mounting screws (5 g, 0.17 oz)
RLK-0640-99-02-00-0	Beveling roller
RLK-0640-99-03-00-0	Radius roller

7. EXPLODED VIEWS AND PARTS LIST

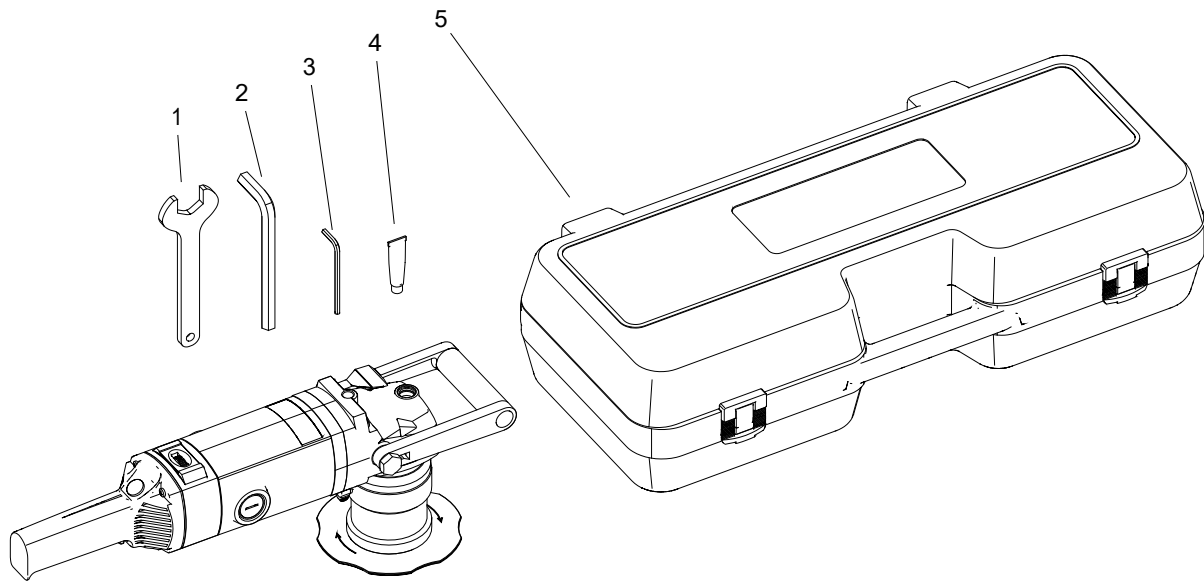

ITEM	PART NUMBER	DESCRIPTION	Q-TY
1	KLC-0509-13-00-00-0	32 MM SPECIAL FLAT WRENCH	1
2	KLC-000029	14 MM HEX WRENCH	1
3	KLC-000008	5 MM HEX WRENCH	1
4	SMR-000005	GREASE FOR SCREWS	1
5	SKR-0670-99-00-00-0	PLASTIC BOX	1
-	GLW-0640-30-02-00-0	MILLING HEAD 30°	1
-	GLW-0640-30-04-00-0	MILLING HEAD 45°	1
-	GLW-0640-30-07-00-0	MILLING HEAD 60°	1
-	GLW-0640-30-06-00-0	MILLING HEAD 55°	1
-	GLW-0640-30-03-00-0	MILLING HEAD 37.5°	1
-	GLW-0640-30-01-00-0	MILLING HEAD 22.5°	1
-	GLW-0640-30-05-00-0	MILLING HEAD 50°	1
-	PLY-000395	BEVELING INSERT FOR STEEL	5
-	PLY-000195	BEVELING INSERT FOR ALUMINIUM	5
-	SRB-000290	MOUNTING SCREW FOR BEVELING INSERT	5
-	PLY-000737	RADIUS INSERT R2	4
-	PLY-000738	RADIUS INSERT R3	4
-	PLY-000739	RADIUS INSERT R4	4
-	PLY-000740	RADIUS INSERT R5	4
-	SRB-000289	MOUNTING SCREW FOR RADIUS INSERT	4

- optional

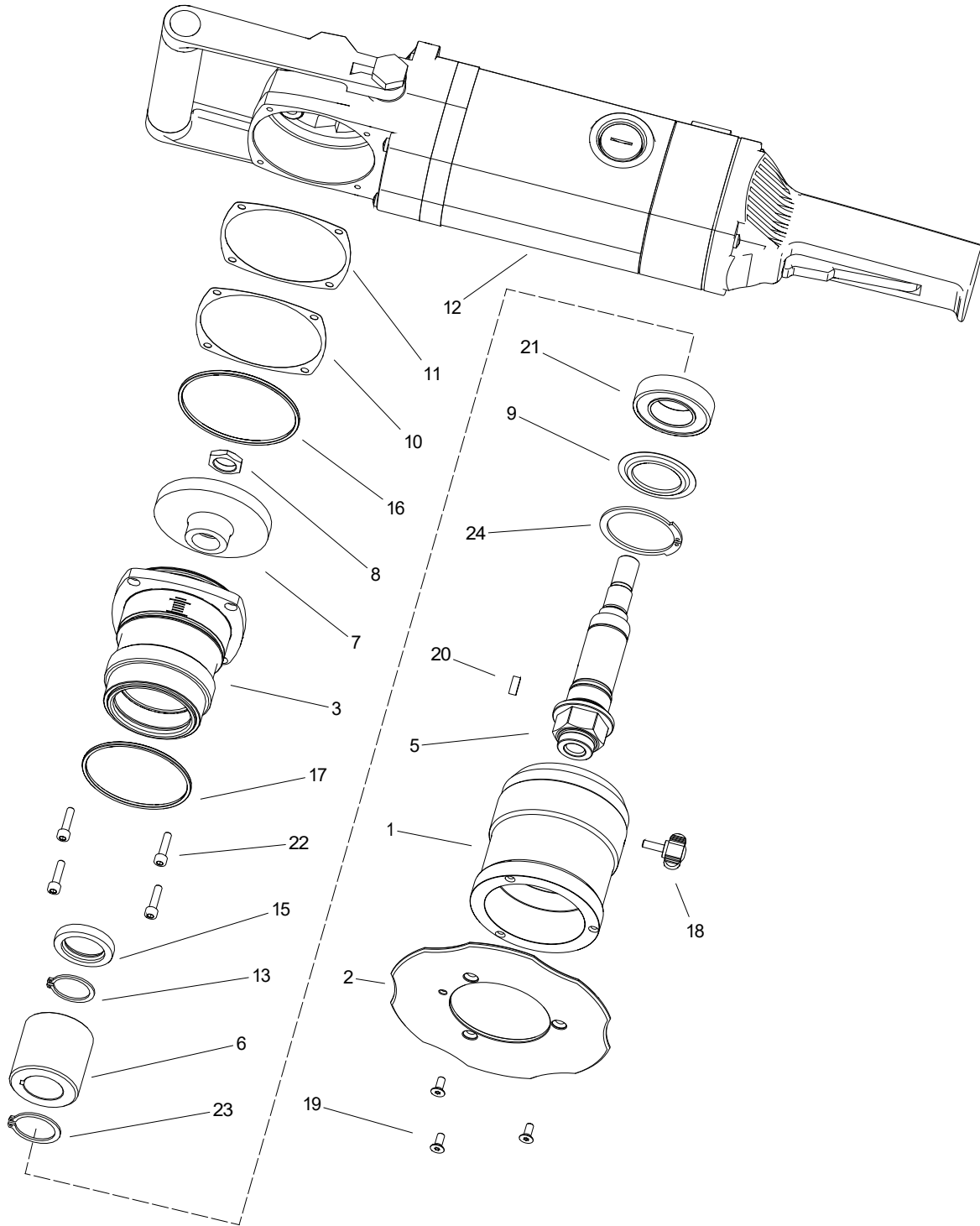

ITEM	PART NUMBER	DESCRIPTION	Q-TY
1	TLJ-0670-04-00-00-0	SLIDING SLEEVE	1
2	PRW-0670-03-00-00-0	GUIDE	1
3	TLJ-0509-01-01-00-1	SPINDLE SLEEVE	1
4	RLK-0640-99-02-00-0	ROLLER FOR BEVEL ASSY	1
5	WRZ-0670-01-02-00-0	SPINDLE	1
6	TLJ-0509-01-03-00-0	DISTANCE SLEEVE	1
7	KOL-0509-01-04-00-0	BEVEL GEAR z=53	1
8	NKR-0509-01-05-00-0	LOCKING NUT	1

ITEM	PART NUMBER	DESCRIPTION	Q-TY
9	PRS-000342	BEARING COVER 35x55x2.5	1
10	PDK-000187	DISTANCE WASHER 0.2	1
11	PDK-000188	DISTANCE WASHER 0.3	1
12	NPD-0680-00-00-00-3	MOTOR ASSY 110V (US)	1
12	NPD-0680-00-00-00-0	MOTOR ASSY 230V (CEE)	1
12	NPD-0680-00-00-00-4	MOTOR ASSY 110V (UK)	1
12	NPD-0680-00-00-00-1	MOTOR ASSY 230V (INDIA)	1
12	NPD-0680-00-00-00-2	MOTOR ASSY 230V (AU)	1
13	PRS-000019	EXTERNAL RETAINING RING 28z	1
15	PRS-000285	SEAL A-RING 28x42x7	1
16	PRS-000286	SEAL O-RING 80x3	1
17	PRS-000274	SEAL O-RING 72x3	1
18	PKT-000060	HANDLEVER	1
19	WKR-000539	TORX COUNTERSUNK HEAD SCREW M5x12	3
20	WPS-000010	KEY 5x5x14	1
21	LOZ-000174	BALL BEARING 30x55x13	1
22	SRB-000086	HEX SOCKET HEAD CAP SCREW M5x20	4
23	PRS-000021	EXTERNAL RETAINING RING 30z	1
24	PRS-000343	INTERNAL RETAINING RING 55w	1

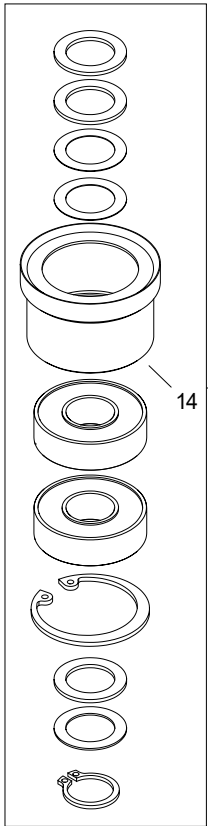
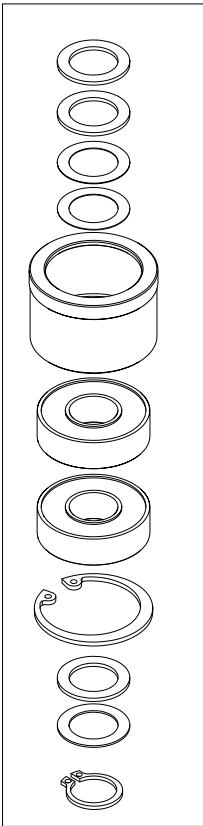
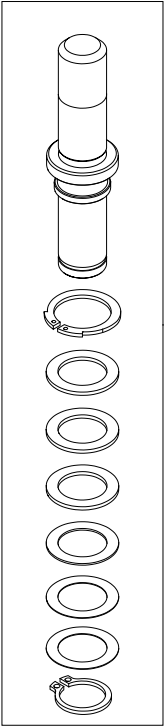
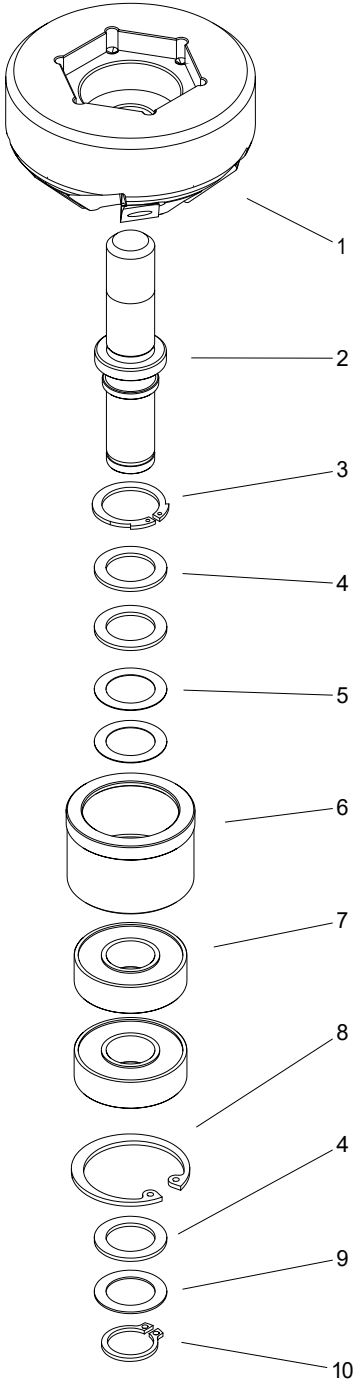

ITEM	PART NUMBER	DESCRIPTION	Q-TY
1	GLW-000038	MILLING HEAD 22,5°	1
1	GLW-000034	MILLING HEAD 30°	1
1	GLW-000036	MILLING HEAD 37,5°	1
1	GLW-000035	MILLING HEAD 45°	1
1	GLW-000039	MILLING HEAD 50°	1
1	GLW-000040	MILLING HEAD 55°	1
1	GLW-000041	MILLING HEAD 60°	1
1	GLW-000042	MILLING HEAD FOR RADII	1
2	SWR-0640-05-02-00-0	ROLLER PIVOT	1
3	PRS-000381	INTERNAL RETAINING RING 18w	1
4	PDK-000164	SPACER WASHER 12x18x1	3
5	PDK-000178	WASHER 12x18x0.2	2
6	RLK-0640-05-01-00-0	ROLLER	1
7	LOZ-000038	BALL BEARING 12x28x8	2
8	PRS-000018	INTERNAL RETAINING RING 28w	1
9	PDK-000218	WASHER 12x18x0.5	1
10	PRS-000003	EXTERNAL RETAINING RING 12z	1
11	SWR-0640-99-01-00-0	ROLLER PIVOT SET	1
12	RLK-0640-99-02-00-0	ROLLER FOR BEVELS SET	1
13	RLK-0640-99-03-00-0	ROLLER FOR RADII SET	1
14	RLK-0640-05-03-00-0	ROLLER FOR RADII	1

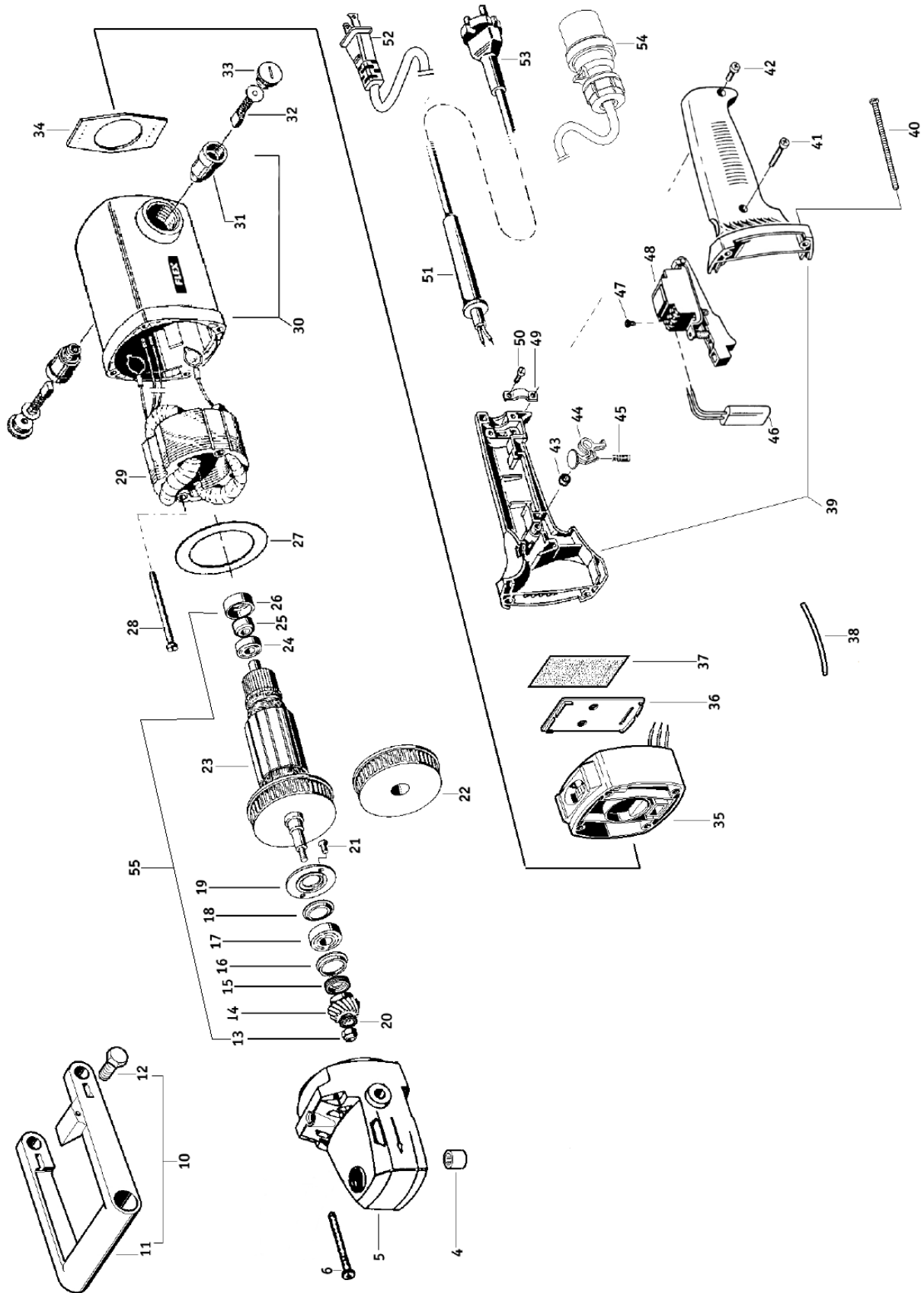

	NPD-0680-00-00-00-3	MOTOR ASSY 110V (US)	
	NPD-0680-00-00-00-0	MOTOR ASSY 230V (CEE)	
	NPD-0680-00-00-00-4	MOTOR ASSY 110V (UK)	
	NPD-0680-00-00-00-1	MOTOR ASSY 230V (INDIA)	
	NPD-0680-00-00-00-2	MOTOR ASSY 230V (AU)	
ITEM	PART NUMBER	DESCRIPTION	Q-TY
4	LOZ-000133	SLIDE SLEEVE HK 1512	1
5	KRP-0680-03-00-00-1	GEAR BODY	1
6	SRB-000338	HEAD SCREW TX25 M5x45	4
10	RKJ-0680-99-00-00-0	FRONT HANDLE ASSY	1
11	RKJ-000060	FRONT HANDLE	1
12	SRB-000341	FULLY THREADED HEX CAP SCREW M14x25	2
13	NKR-000145	NUT M8x1	1
14	KOL-000089	BEVEL GEAR MZ 1.5x12	1
15	DYS-000009	DISTANCE	1
16	USZ-000044	SEALING	1
17	LOZ-000135	BALL BEARING 15x35x11	1
18	USZ-000045	SEALING 6003JV	1
19	PKR-0680-12-00-00-0	COVER	1
20	PDK-000189	WASHER NL8	1
21	WKR-000433	HEX SOCKET COUNTERSUNK HEAD SCREW M5x16	2
22	WNT-000009	FAN	1
23	WRN-0680-06-00-00-0	ROTOR 230V	1
23	WRN-0680-05-00-00-0	ROTOR 110V	1
24	LOZ-000136	BALL BEARING 12x28x8	1
25	PRS-000292	MAGNETIC RING	1
26	LOZ-000137	BEARING	1
27	OSL-000187	STATOR GUARD 230/CEE	1
28	SRB-000343	SCREW KT-KT 5x74	2
29	STN-0680-08-00-00-0	STATOR 230V	1
29	STN-0680-07-00-00-0	STATOR 110V	1
30	ZSP-0680-11-00-00-0	STATOR HOUSING 230V	1
30	ZSP-0680-10-00-00-0	STATOR HOUSING 110V	1
31	SCT-000010	BRUSH HOLDER 230V	2
31	SCT-000011	BRUSH HOLDER 110V	2
32	SCZ-000030	BRUSH 230V	2
32	SCZ-000031	BRUSH 110V	2
33	PKR-000046	BRUSH HOLDER COVER	2
34	PKR-000047	HANDLE COVER SB	1
35	MDL-0680-80-02-00-0	ROTATIONAL SPEED CONTROLLER UNIT 230V	1
35	MDL-0680-80-01-00-0	ROTATIONAL SPEED CONTROLLER UNIT 110V	1
36	PKR-000048	CONTROLLER BODY COVER	1
37	PDK-000193	INSULATION WASHER	1
38	OSL-000189	WIRE SHIELD GF	1
39	RKJ-0680-99-03-00-0	HANDLE BODY	1
40	SRB-000343	SCREW KT-KT 5x74	4
41	SRB-000344	SCREW KT-KT 4x30	1
42	SRB-000345	SCREW KT-KT 4x20	1
43	TLJ-000108	LOCK SLEEVE	1
44	BLD-000016	SWITCH LOCK	1

NPD-0680-00-00-00-3		MOTOR ASSY 110V (US)	
NPD-0680-00-00-00-0		MOTOR ASSY 230V (CEE)	
NPD-0680-00-00-00-4		MOTOR ASSY 110V (UK)	
NPD-0680-00-00-00-1		MOTOR ASSY 230V (INDIA)	
NPD-0680-00-00-00-2		MOTOR ASSY 230V (AU)	
ITEM	PART NUMBER	DESCRIPTION	Q-TY
45	SPR-000052	SPRING	1
46	KND-000138	CAPACITOR X2 0.22uF	1
47	SRB-000348	SCREW M3.5x7 DK4.1	1
48	WLC-000035	SWITCH	1
49	WSP-000059	WIRE BRACKET PA6	1
50	SRB-000345	SCREW KT-KT 4x20	2
51	OSL-000191	WIRE SHIELD fi9	1
51	OSL-000192	WIRE SHIELD fi11	1
52	PWD-0680-09-00-01-0	POWER CORD AWG 16/2 SJ 120 (US)	1
53	PWD-0680-04-00-00-0	POWER CORD H07RN-F 2x1Qx4M	1
54	PWD-0680-09-00-02-0	POWER CORD WITH PLUG BS 4343	1
55	WRN-0680-99-01-00-0	ROTOR ASSY – 120V	1
55	WRN-0680-99-02-00-0	ROTOR ASSY – 230V	1
56*	PWD-0212-10-02-00-6	POWER CORD 230V 3x1.5 WITH STRAIN RELIEF ASSY (INDIA)	1
57*	PWD-0509-99-00-00-0	POWER CORD 230V ASSY (JAPAN)	1

* not shown in the drawing

8. DECLARATION OF CONFORMITY

Declaration of Conformity

PROMOTECH sp. z o.o.
ul. Elewatorska 23/1
15-620 Białystok
Poland

We declare with full responsibility that:

BM-18 BEVELING MACHINE

is manufactured in accordance with the following standards:

- EN 60745-1
- EN 55014
- EN ISO 12100

and satisfies the regulations of the guidelines: 2014/30/EU, 2014/35/EU, 2006/42/EC, 2011/65/EU, 2012/19/EU.

Person authorized to compile the technical file:

Wiktor Marek Siergiej, ul. Elewatorska 23/1, 15-620 Białystok, Poland



Białystok, 23 August 2019

Wiktor Marek Siergiej
CEO

9. ENVIRONMENTAL PROTECTION

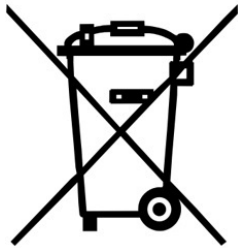

In accordance with the European Directive 2012/19/EU, this device is marked with the symbol of the crossed-out waste bin. This marking means that the equipment must not be disposed of with other household waste after the service life. The user must return the product to a collection point for used electrical and electronic equipment. The collectors of used equipment, including local collection points, shops and municipal units create an appropriate system for returning such equipment. Correct handling of used electrical and electronic equipment helps in avoiding damage to health and the environment, which may result from the presence of dangerous components and incorrect storage and processing of such equipment.

10. WARRANTY CARD**WARRANTY CARD No.....**

..... in the name of Manufacturer warrants the BM-18 Beveling Machine to be free of defects in material and workmanship under normal use for a period of 12 months from the date of sale.

This warranty does not cover cutting inserts as well as damage or wear that arise from misuse, accident, tempering, or any other causes not related to defects in workmanship or material.

Serial number

Date of sale

Signature and stamp of the seller

0.05 / 23 March 2023

WE RESERVE THE RIGHT TO MAKE CHANGES IN THIS MANUAL WITHOUT NOTICE