

D1 PRO X PORTABLE MAGNETIC DRILL

MULTI PURPOSE LIGHTWEIGHT MAGNETIC DRILL

The Steelmax D1 PRO X is an extremely durable, rigorously constructed drilling machine that is purposely designed for longevity. The 440 RPM motor (under load) makes it optimal to use with HSS and TCT annular cutters. Lightweight, compact and portable, this magnetic drill features a powerful 1100-watt motor capable of drilling with annular cutters up to 1-9/16" (40 mm) diameter holes through 2" (50 mm) thick material. The optional drill chuck can be used with solid, twist drills up to 5/8" (16 mm) diameter and the large stroke enables easy use of longer tools. Drill body is updated with increased stiffness along with gearbox housing and ribs.

The D1 PRO X is equipped with the most advanced electromagnetic technology. Using only 50% power when the motor is not under load, the Energy Saving Base (ESB) reduces excessive heat build-up and dramatically increases the operating life of the electromagnet. Our Magnetic Field Shape Control (MFSC) system provides maximum holding power on thin materials. The integrated Magnetic Power Adhesion Control Module (MPAC) detects the adhesive force of the electromagnetic base and prevents drill activation when there is insufficient adhesive power, protecting both the machine and the operator.

FEATURES

- Up to 1-9/16" diameter and 2" depth of cut
- 6" Stroke
- Magnetic Power Adhesion Control (MPAC)
- Magnetic Field Shape Control (MFSC)
- Energy Saving Base (ESB)
- Comes complete with swarfshield
- Motor cable with additional protective cover



Steelmax

The tools of innovation.

D1 Pro X Technical Specifications	
Motor Speeds (under load)	440 rpm
Power	1100 W
Voltage	1 ~ 110-120 V, 50-60 Hz 1 ~ 220-240 V, 50-60 Hz
Max drilling capacity	5/8" (16 mm)
Annular cutting capacity	1 9/16" (40 mm)
Magnetic Base Dimensions	3.3 × 6.6 × 1.6 (") 84 × 168 × 41.5 (mm)
Stroke	6.3" (160 mm)
Max Depth of Cut	2" (50 mm)
Min. work piece thickness	3/8"
Spindle	3/4" (19 mm) Weldon
Tool Holder	3/4" (19 mm) Weldon
Part Number	SM-D1-Pro-X SM-D1-Pro-X-230
Weight	29 lbs (13 kg)



Basic set:

- Magnetic base drilling machine
- Dedicated plastic box
- 3/4" (19 mm) Weldon Arbor – with cooling ring
- Swarf shield/Cutter guard with guideway
- Coolant bottle assembly
- Handle (3 piece)
- Set of tools
- Operators manual
- Safety strap

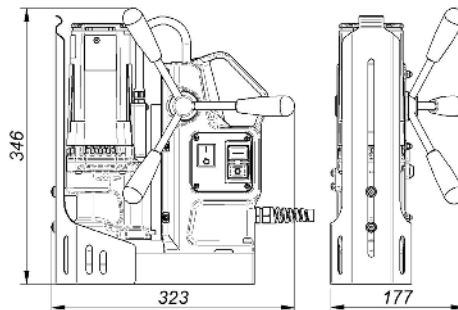

Optional Accessories:

SM-DC-PRO40-WSA* Weldon Shank 3/4" Adapter

SM-DC-PRO40* Drilling Chuck 16-1/2" - 20 UNF

*Items necessary for use with twist drill bits.

Steelmax

The tools of innovation.



For ordering and customer service, or to request detailed product information or demonstration videos, contact:

303-690-9146

STEELMAX.COM

sales@Steelmax.com

Fax: 303-690-9172