



The tools of innovation.

OPERATOR'S MANUAL

D3X RS

DRILLING MACHINE WITH ELECTROMAGNETIC BASE

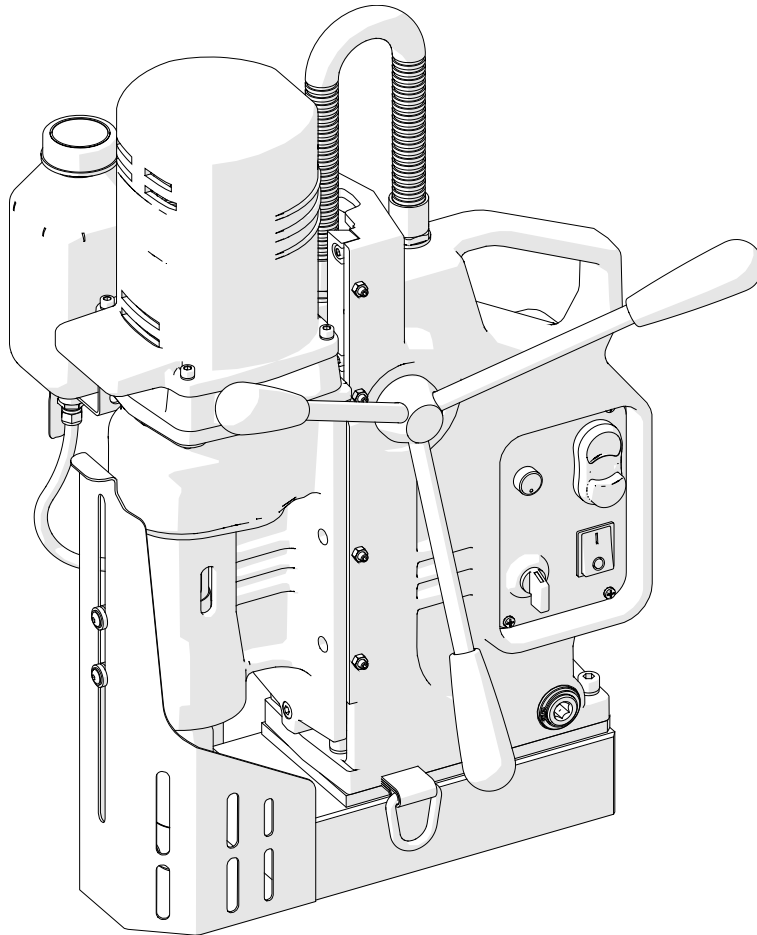

15335 E. Fremont Drive, Centennial, CO 80112

1-87STEELMAX, FAX 303-690-9172

www.steelmax.com sales@steelmax.com

Contents

1. GENERAL INFORMATION	3
1.1. Application	3
1.2. Technical data.....	3
1.3. Design	5
1.4. Equipment included	5
2. SAFETY PRECAUTIONS.....	6
3. STARTUP AND OPERATION	8
3.1. Installing and removing the arbor, MT3 twist drill bit, or tap chuck.....	8
3.2. Installing, removing, and operating the annular cutter	10
3.3. Installing and removing the screw tap	12
3.4. Installing and removing the cooling system	13
3.5. Control system of the electromagnetic base holding force	14
3.6. Preparing	14
3.7. Positioning the machine precisely	16
3.8. Drilling.....	17
3.9. Tapping.....	18
3.10. Adjusting the gib clearance	19
3.11. Replacing the motor brushes.....	21
4. ACCESSORIES	22
4.1. Pressure cooling system	22
4.2. Arbor MT3 x 32 mm Weldon	22
4.3. Quick change arbor MT3 x 19 mm Weldon	23
4.4. Pipe attachment DMP 501	23
5. WIRING DIAGRAM	24
6. D3X RS EXPLODED DRAWINGS AND PARTS LIST	25
7. DECLARATION OF CONFORMITY	31
8. QUALITY CERTIFICATE.....	32
9. WARRANTY CARD.....	33

1. GENERAL INFORMATION

1.1. Application

The D3X RS is a drilling machine with electromagnetic base, designed to drill holes either with diameters of 12–75 mm (0.47–2.95”) to a depth up to 76 mm (3”) using annular cutters or with diameters of 8–32 mm (0.31–1.26”) to a depth up to 76 mm (3”) using twist drill bits. In addition, it is capable to change the rotation direction to allow tapping by using a tap chuck with axial compensation.

The electromagnetic base allows the drilling machine to be fixed to ferromagnetic surfaces with a force that ensures operator safety and proper machine operation. A safety chain protects the machine from dropping in case of a power loss.

The D3X RS has a swivel base and thus is capable to be rotated in a range of $\pm 15^\circ$ and to be moved out up to 15 mm (0.6”) without moving the electromagnetic base.

Accessories allow, for instance, quick changing of tools or drilling in pipes.

1.2. Technical data

Voltage	1~ 110–120 V, 50–60 Hz 1~ 220–240 V, 50–60 Hz
Total power	1800 W
Motor power	1650 W
Spindle shank	MT3
Tool holder	19 mm Weldon (3/4”)
Drilling diameter with annular cutter	12–75 mm (0.47–2.95”)*
Drilling diameter with twist drill bit	8–32 mm (0.31–1.26”)
Maximum drilling depth	76 mm (3”)
Maximum tap size	M24 (G3/4”)
Electromagnetic base holding force (surface with the thickness of 22 mm and roughness $R_a = 1.25$)	19 500 N
Electromagnetic base dimensions	110 mm × 220 mm × 56 mm 4.3” × 8.7” × 2.2”
Stroke	225 mm (8.9”)
Rotational speed under load	80–160 rpm (gear I) 210–420 rpm (gear II)
Minimum workpiece thickness	10 mm (0.39”)
Protection class	I
Noise level	More than 85 dB
Required ambient temperature	0–40°C (32–104°F)
Weight	27 kg (60 lbs)

* If more than 60 mm (2.3”), MT3 arbor with 32 mm Weldon tool holder required (UCW-0191-00-00-00-0).

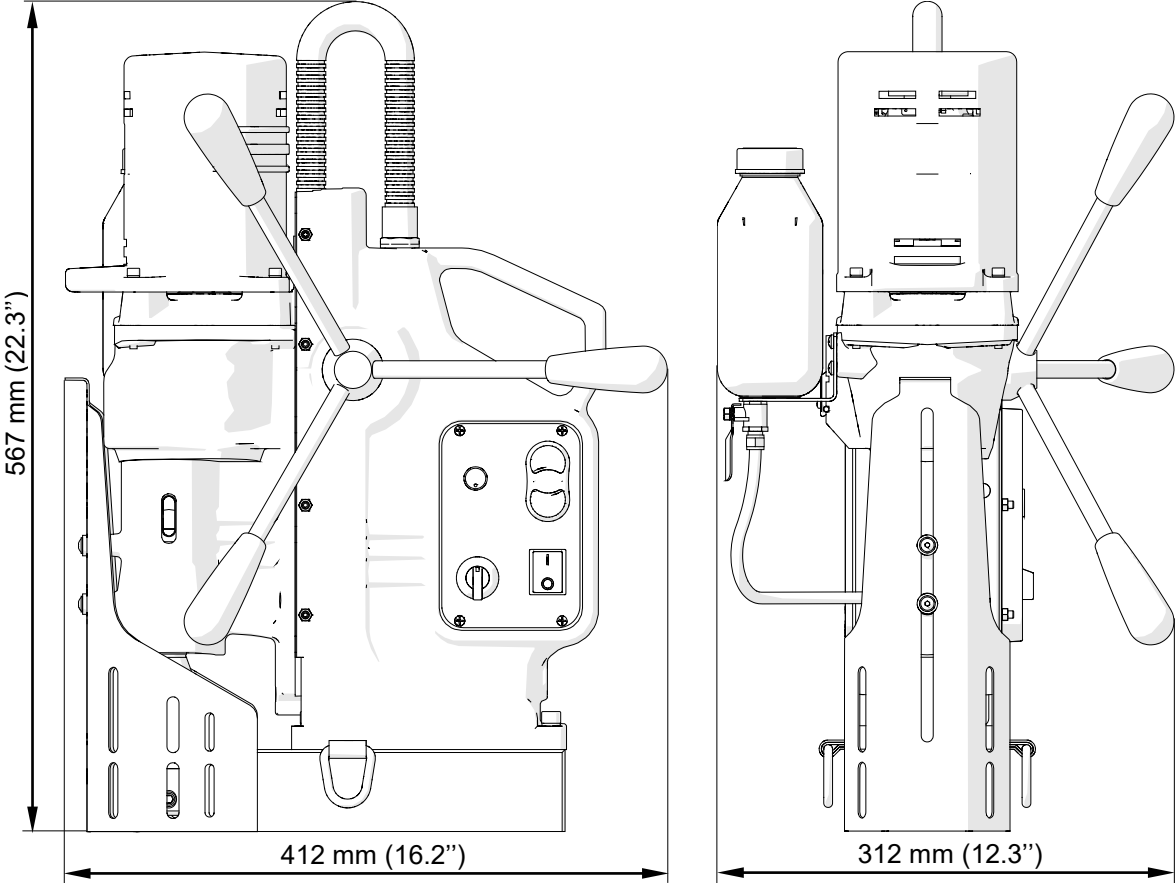

1.3. Design

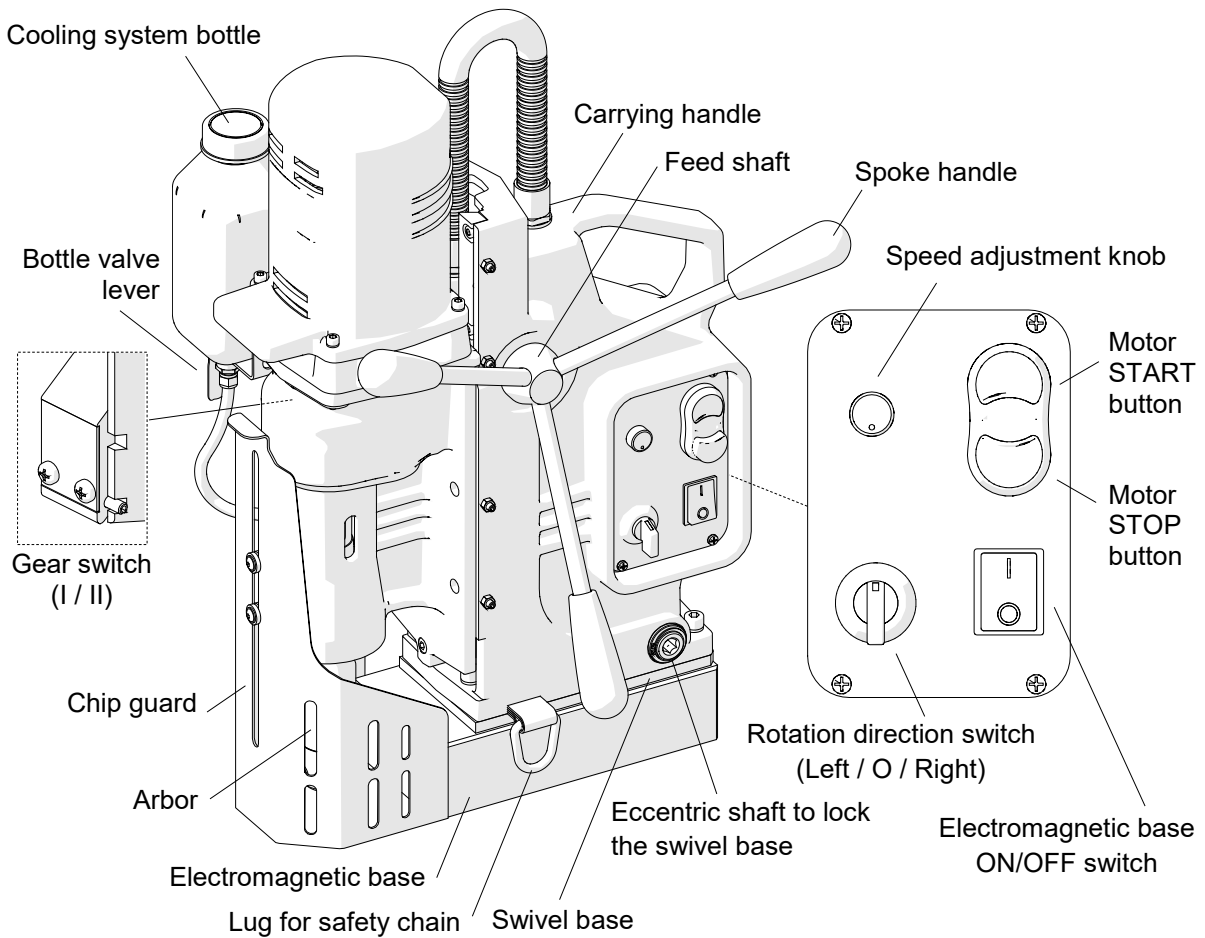

Fig. 1. View of the D3X RS

1.4. Equipment included

The drilling machine is supplied including the following elements.

Drilling machine	1 unit
Metal box	1 unit
Spoke handle	3 units
MT3 arbor with 19 mm (3/4") Weldon tool holder	1 unit
Cooling system	1 unit
1.5 m (5 ft) safety chain	1 unit
MT3 drift	1 unit
2.5 mm hex wrench	1 unit
4 mm hex wrench	1 unit
5 mm hex wrench with handle	1 unit
6 mm hex wrench	1 unit
10 mm hex wrench	1 unit
8 mm combination wrench	1 unit
Tool can	1 unit
Operator's Manual	1 unit

2. SAFETY PRECAUTIONS

1. Before beginning, read this Operator's Manual and complete proper occupational safety and health training.
2. Use the machine only in applications specified in this Operator's Manual.
3. The machine must be complete and all parts must be genuine and fully operational.
4. The specifications of the power source must conform to those specified on the rating plate.
5. Connect the machine to a properly grounded power source. The power source must be protected with a 16 A fuse for 230 V or a 32 A fuse for 115 V. When used on building sites, supply the machine through an isolation transformer with class II protection only.
6. Never carry the machine by the power cord and never pull the cord because this may damage it and result in electric shock.
7. Transport and position the machine using the carrying handle and only when the magnet switch is set to the position 'O'.
8. Untrained bystanders must not be present near the machine.
9. Before beginning, make sure that the correct is the condition of the machine, power source, power cord, plug, control panel components, and tools.
10. Keep the machine dry. Exposure to rain, snow, or frost is prohibited.
11. Never stay below the machine placed at heights.
12. Keep the work area well lit, clean, and free of obstacles.
13. Install the tools securely. Tighten the annular cutter using set screws. Hammer in the drill bit into the spindle using a mallet. Remove adjusting keys and wrenches from the work area before connecting the machine to the power source.
14. Never use cutters that are dull or damaged.
15. Do not make holes whose diameter or depth differ from those specified in the technical data.
16. Install and remove tools using protective gloves and only when the power cord is unplugged from the power source.
17. Never use annular cutters without a pilot pin except when drilling incomplete through holes. Never use arbors without a spring.
18. Never use near flammable liquids or gases, or in explosive environments.
19. Using the machine on surfaces that are rusty, covered with a thick paint layer, uneven, or not rigid is prohibited.

20. Do not start operation if the gib clearance is excessive.
21. Use the safety chain in all operating positions. Attach the machine to a fixed structure by fastening the chain to the lugs or the carrying handle. The chain must not be loose. Wrap the chain around the workpiece if possible.
22. Before every use, inspect the machine to ensure it is not damaged. Check whether any part is cracked or improperly fitted. Make sure to maintain proper conditions that may affect the operation of the machine.
23. Always use eye and hearing protection and protective clothing during operation. Do not wear loose clothing.
24. Drilling in plates with a thickness less than 10 mm (0.4") is not recommended because the holding force depends on material thickness and is significantly lower for thin plates.
25. The entire bottom of the electromagnetic base must be in full contact with the workpiece. Before every positioning, wipe the workpiece with coarse-grained sandpaper.
26. Do not touch moving parts or chips formed during milling. Prevent objects from being caught in moving parts.
27. After every use, remove metal chips and excess coolant from the machine. Do not remove chips with bare hands.
28. Cover steel parts with a thin anti-corrosion coating to protect the machine from rust when not in use for any extended period.
29. Maintain the machine and install/remove parts and tools only when the machine is unplugged from the power source.
30. Repair only in a service center appointed by the seller.
31. If the machine falls from any height, is wet, or has any other damage that could affect the technical state of the machine, stop the operation and immediately send the machine to the service center for inspection and repair.
32. Never leave the machine unattended during operation.
33. Remove from the worksite and store in a secure and dry location when not in use, previously removing the tool from the holder.

3. STARTUP AND OPERATION

3.1. Installing and removing the arbor, MT3 twist drill bit, or tap chuck

Unplug the machine from the power source, raise the chip guard as high as possible (1, Fig. 2), and then rotate the spoke handles to the right (2) to raise the motor. Use a clean and dry cloth to wipe the spindle and arbor (drill bit, tap chuck). Next, wear protective gloves and insert the arbor (drill bit, tap chuck) into the spindle (3), and then rotate the arbor (drill bit, tap chuck) to the right (4) until it slips into place. Finally, firmly tap the arbor (drill bit, tap chuck) into place using a mallet (5).

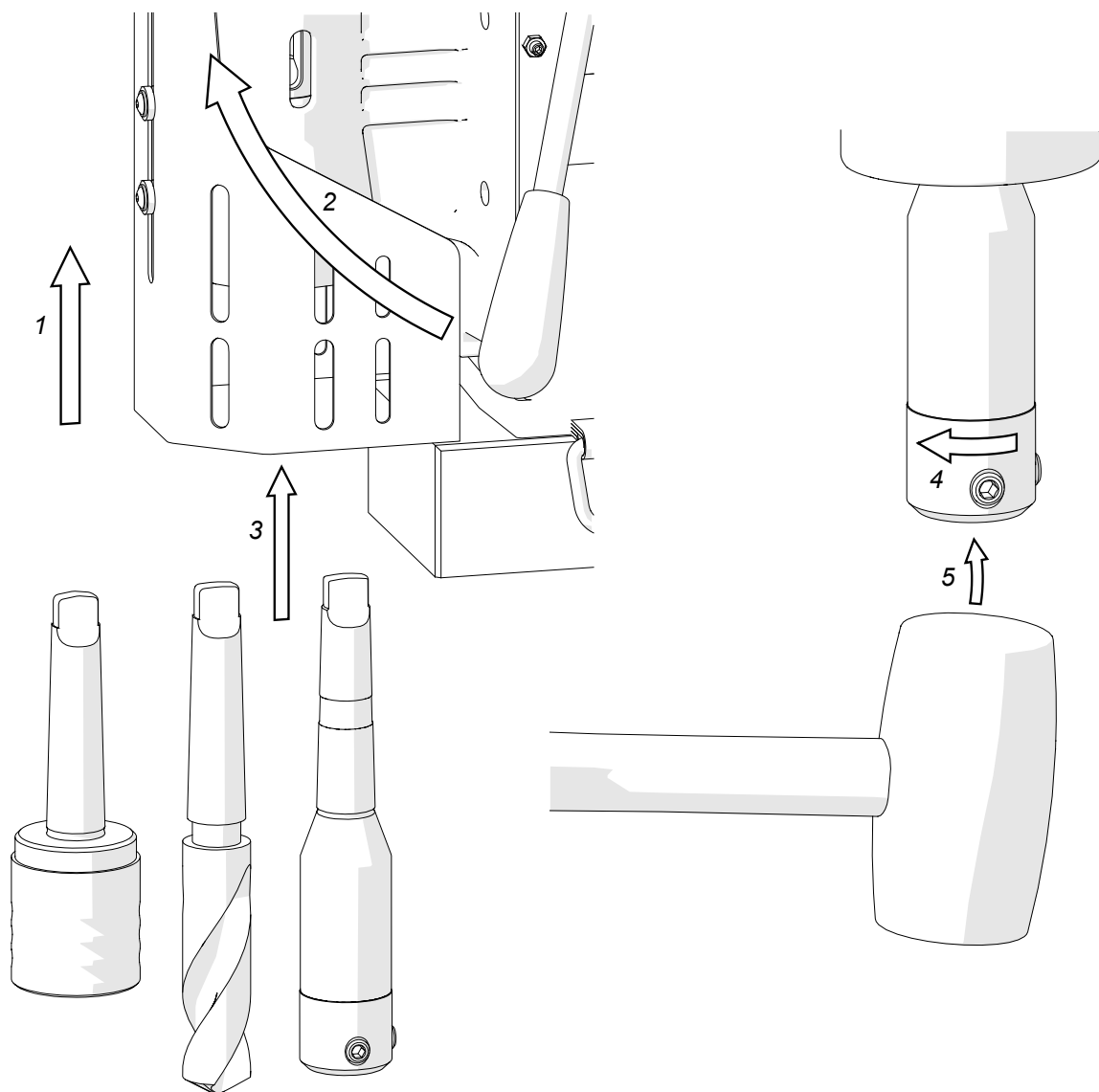

Fig. 2. Installing the arbor, drill bit, or tap chuck

To remove the arbor (drill bit, tap chuck), raise the motor, and then rotate the spindle (1, Fig. 3) in such a way to align the openings in the spindle and gearbox (2). Next, insert the MT3 drift (3) into the opening above the arbor (drill bit, tap chuck), hold the carrying handle with one hand, and then tap the drift using a mallet (4).

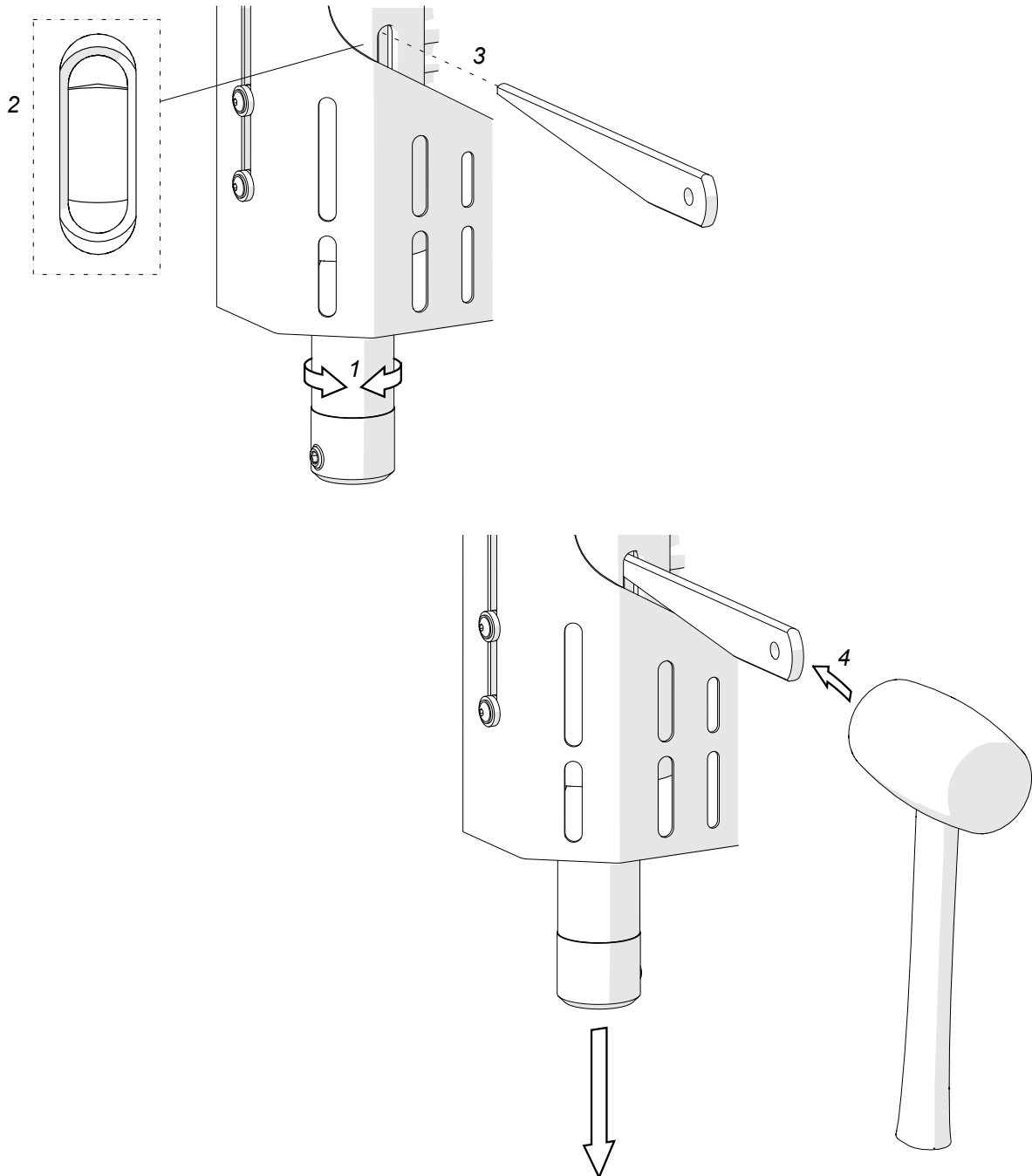

Fig. 3. Removing the arbor, drill bit, or tap chuck

3.2. Installing, removing, and operating the annular cutter

Install the arbor as described before, wear protective gloves, and then insert the proper pilot pin into the annular cutter (1, Fig. 4). Use a clean and dry cloth to wipe the cutter. Next, place the cutter into the arbor (2) in such a way to align the flats 3 with the set screws 4, and then use the 5 mm hex wrench to tighten both set screws.

To remove the cutter, loosen the screws 4 using the 5 mm hex wrench.

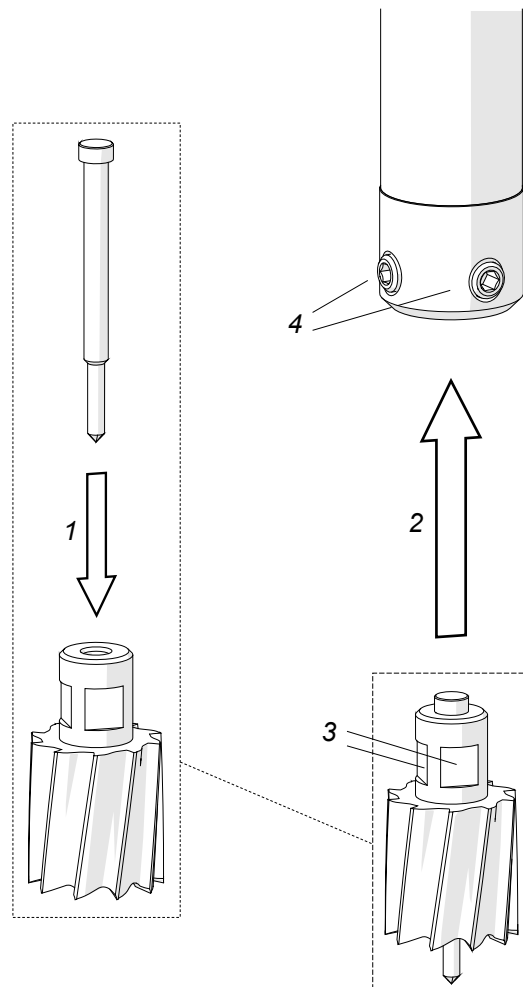

Fig. 4. Installing the annular cutter

Fig. 5 shows how annular cutters operate. As the cutter penetrates the workpiece, the pilot pin recesses into the arbor and tightens the spring. As a result, after the cutter goes through the entire thickness, the slug core is expelled from the cutter. When pressed, the pilot pin also allows application of coolant to the inner surface of the annular cutter.

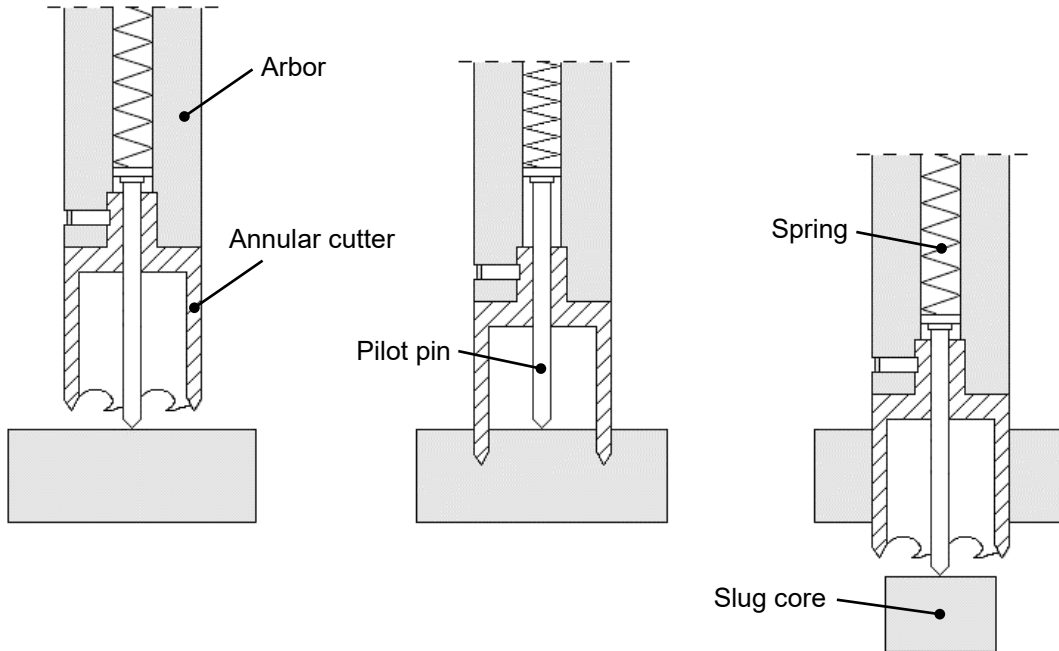

Fig. 5. Annular cutters operation

Annular cutters are designed to make only through holes shown in Fig. 6. When drilling incomplete through holes the pilot pin must not be used.

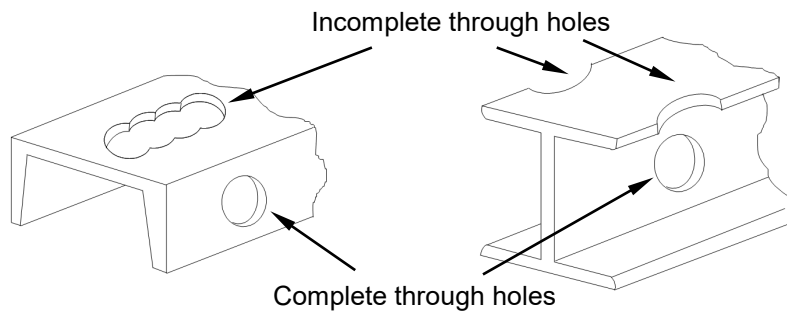

Fig. 6. Types of holes to make with annular cutters

3.3. Installing and removing the screw tap

Install the tap chuck with axial compensation as described before. Next, insert the entering tap (tap no. 1) into the proper adapter (1, Fig. 7), and then install the adapter into the tap chuck (2). Install screw taps with a MT3 shank through a MT sleeve.

To remove the screw tap, unlock it and remove from the adapter.

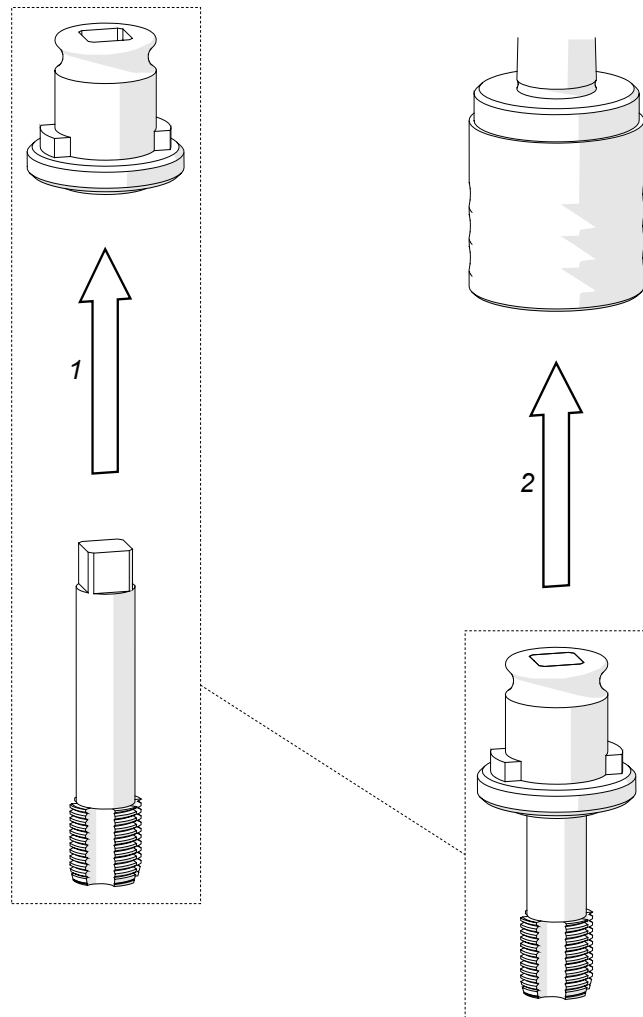

Fig. 7. Installing the screw tap

3.4. Installing and removing the cooling system

Hang the cooling system bottle on the screws (1, Fig. 8), and then attach the bottle hose to the hose fitting (2).

To remove the bottle, proceed in reverse order.

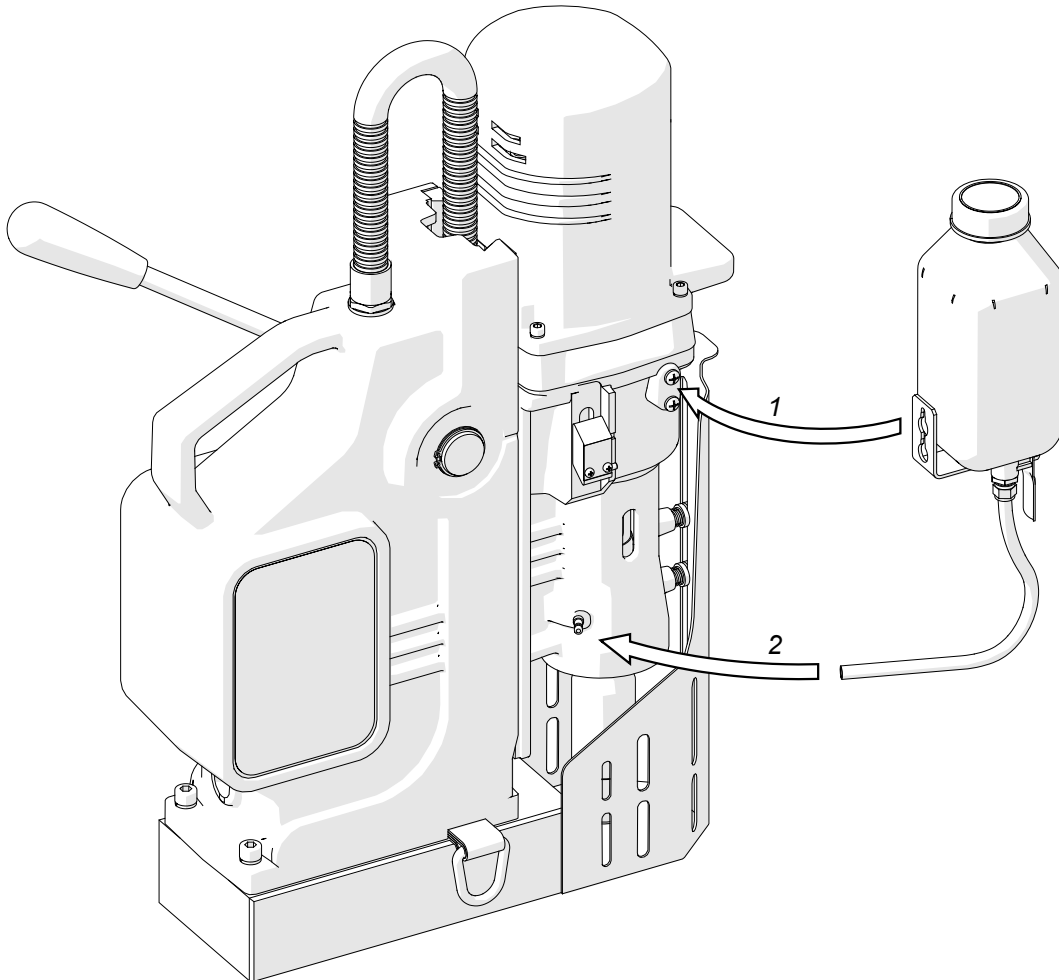

Fig. 8. Installing the cooling system

3.5. Control system of the electromagnetic base holding force

The D3X RS drilling machine incorporates a holding force control system to monitor the clamping of the electromagnetic base to the surface. The force value depends on several factors, such as type, thickness, flatness, and roughness of the surface, presence of paint, rust, or other contaminants, fluctuations of supply voltage, and the wear of the electromagnetic base bottom.

If the holding force falls below a safe operating value, the control system will not allow the machine to operate. Additionally, the system will prevent the startup of the motor on a surface thinner than 5 mm (0.2") because such thickness does not provide sufficient holding force. In such a case, the holding force will be only about 25% of the force attained on a standard 22-mm (0.87") flat plate.

If the motor does not continue operation after the green MOTOR button is pressed and released, it means that the control circuit is operating properly and preventing further drilling because the holding force is too low.

3.6. Preparing

Before beginning, clean steel parts, including the MT3 shank, from anti-corrosion coating used to preserve the machine for storage and transport.

Screw the spoke handles into the feed shaft. The feed shaft can be installed at the opposite side of the drilling machine to allow working in places hard to reach or using the machine by a left-handed person.

Select the proper annular cutter, drill bit, or screw tap based on the hole size desired. Next, use a clean and dry cloth to wipe the spindle, arbor (drill bit, tap chuck), and cutter, and then install the arbor (and then the cutter), drill bit, or tap chuck (and then the screw tap with adapter) as described before.

Position the machine on a flat ferromagnetic surface (some types of stainless and acid-proof steel do not conduct magnetic flux) with a thickness of at least 10 mm (0.4"). The workpiece must be clean, without rust or paint that decrease the holding force of the electromagnetic base.

Connect the drilling machine to the power source, and set the MAGNET switch to the position 'I' to turn on the clamping of the electromagnetic base.

Use the safety chain to prevent the machine from dropping and avoid possible injury to the operator if the machine loses magnetic clamping in case of a power loss.

To protect the machine, attach it to a fixed structure by fastening the chain to the lugs or the carrying handle (Fig. 9). The chain must not be loose. Wrap the chain around the workpiece if possible.

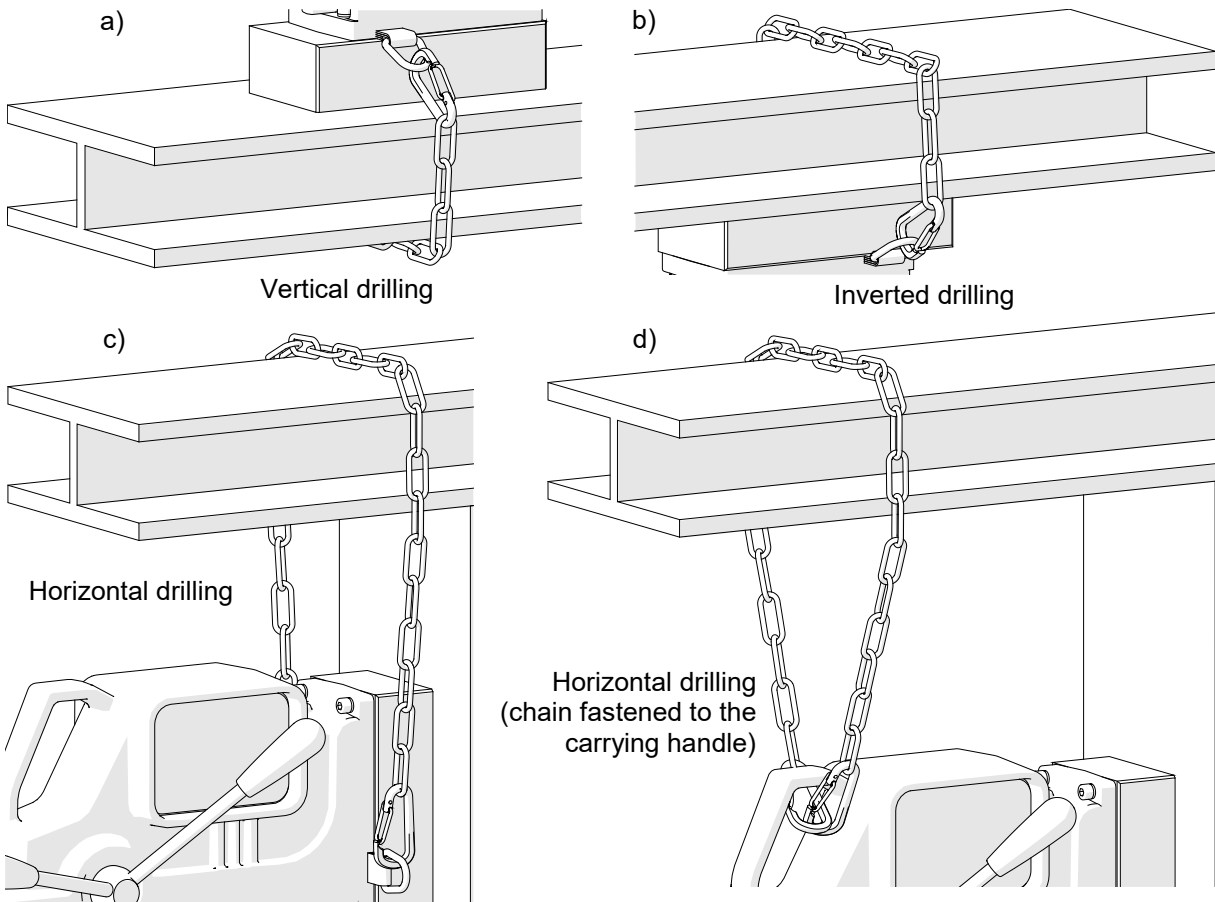

Fig. 9. Protecting the machine from dropping using the safety chain

Rotate the spoke handles to the left to place the tool above the workpiece.

When using the annular cutter and working in the position from Fig. 9a, install the cooling system as described before, and fill it with a cutting fluid. Do not use pure water as the cutting fluid. However, using emulsions formed from mixing water and drilling oil is satisfactory. To check the operation of the cooling system, slightly loosen the bottle cap, open the valve using the lever, and then rotate the spoke handles to the left to initially apply pressure on the pilot pin. The fluid should fill the system and begin flowing from the inside of the cutter.

Because the cooling system works by means of gravitation, use a cooling paste when working in horizontal or inverted positions.

3.7. Positioning the machine precisely

To rotate or to move out the machine body when the electromagnetic base is clamped to the workpiece, use the 10 mm hex wrench to unlock the eccentric shaft (1, Fig. 10), set the body in desired position, and then lock the shaft (2).

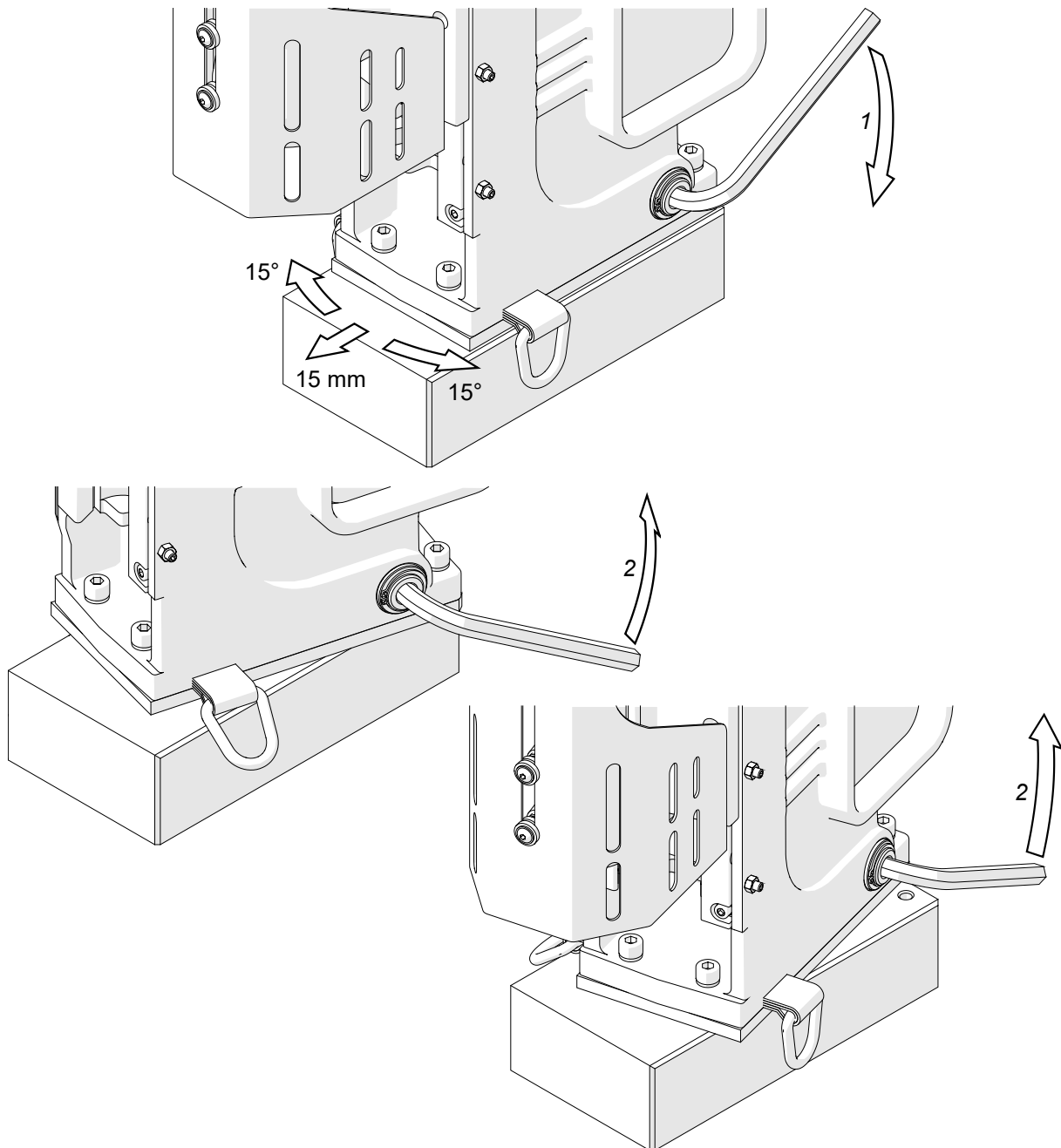

Fig. 10. Positioning the D3X RS precisely

3.8. Drilling

Use the gear switch to set the speed based on the following table.

Tool	Hole diameter		Rotational speed* [rpm]
	[mm]	[in.]	
Annular cutter	12–34	0.47–1.34	210–420 (gear II)
	35–75	1.38–2.95	80–160 (gear I)
Twist drill bit	8–17	0.31–0.67	210–420 (gear II)
	18–32	0.71–1.26	80–160 (gear I)

* for sharp tool and mild steel with a shear strength $R_m < 500 \text{ N/mm}^2$ (70,000 psi), such as for instance St0 (S185), St3S (S235JR), or St4W (S275JO)

Steel with a shear strength $R_m = 500\text{--}700 \text{ N/mm}^2$ (70,000–100,000 psi), such as for instance St5 (E295), 18G2A (S355N), or 45 (C45), requires lower rotational speed. If the speed is selected too high or low for the shear strength and the type/diameter of the tool, the tool will wear faster or be unable to drill the hole.

Set the rotation direction switch to the position 'R', and start the motor using the green MOTOR button. Slowly rotate the spoke handles to the left to lower the tool to the workpiece, and begin drilling. Next, use the speed adjustment knob to set a speed suitable for given process conditions.

When using annular cutters, drill holes in one pass.



When the annular cutter goes through the workpiece, the slug core is expelled from the cutter with a significant force.

When using drill bits, drill holes with diameters of 18–32 mm (0.71–1.26") in two passes. Drill a first hole using a drill bit with the 70% diameter of the hole size desired, and then drill again using the bit with diameter equal to the hole size desired.

When drilling holes deeper than 50 mm (2"), retract the tool above the workpiece as often as possible to allow chips to be removed from the hole. If the grooves of the tool are clogged, stop the motor and use a brush to clean them. After the drilling depth exceeds 40 mm (1.6"), apply the cutting fluid manually into the drilling area.

If the operation results in an overload, caused by insufficient cooling, using dull tool, or too fast feed in relation to the tool diameter, the machine will automatically stop. In such a case, to restart the machine, press the red MOTOR button, retract the tool from the workpiece, and then press the green MOTOR button (the electromagnetic base must remain powered).

After the hole is made, retract the tool from the workpiece and press the red MOTOR button to stop the motor. Before moving the machine to another drilling spot, set the MAGNET switch to the position 'O' to turn off the electromagnetic base.

After the work is finished and the motor is stopped, switch to the opposite gear (for instance from gear I to II), and then run the machine for a while without load, which will improve lubricity. Next, turn off the motor and the electromagnetic base, unplug the machine from the power source, clean chips and excess coolant from the machine and tool, and then remove the machine from the worksite.

Tighten the bottle cap, close the valve, and then press the pilot pin to expel the coolant remaining within the cooling system. Before inserting the machine into the tool box, remove the bottle, and then wear gloves to remove the tool from the holder.

3.9. Tapping

With the entering tap (tap no. 1) installed, use the gear switch to set the gear I, and set the rotation direction switch to the position 'R'.

Rotate the spoke handles to the left to place the tap above a hole with diameter appropriate for the tap used. If the diameter of the hole is too small, tapping may be impossible due to excessive milling resistance and insufficient motor power.

Spread tap oil on the cutting part of the screw tap to prevent seizure and extend durability. Next, press the green MOTOR button to start the motor, and then slowly rotate the spoke handles to the left to lower the tap to the workpiece, and begin tapping. After tapping with the entering tap (tap no. 1) is finished, press the red MOTOR button to stop the motor, and set the rotation direction switch to the position 'L'. Next, press and hold the green MOTOR button to retract the tap from the hole, and then release the button.

After the motor is stopped, replace the entering tap (tap no. 1) with the bottoming tap (no. 3), and repeat tapping by proceeding as described before.

After the work is finished and the motor is stopped, set the gear II, and then run the machine for a while without load, which will improve lubricity.

Next, turn off the motor and the electromagnetic base, and then unplug the machine from the power source.

3.10. Adjusting the gib clearance

Every 50 operation hours, or more often, check the gib clearance because it greatly influences the quality of drilled holes. The clearance is appropriate if the motor slides smoothly and not drops under its own weight.

To remove the excessive clearance, use the 8 mm combination wrench to loosen the nuts (1, Fig. 11), and then use the 2.5 mm hex wrench to loosen the set screws (2). Next, rotate the spoke handles to set the motor on such a level to access the gib screws through the holes, use the 4 mm hex wrench to loosen these screws (3), and then tighten (4) with a force enough to prevent the gib from being pushed out by the springs located inside.

Use the 2.5 mm hex wrench to tighten the set screws (5) to such an extent that the motor moves smoothly through the entire stroke and not drops under its own weight. Next, use the 4 mm hex wrench to tighten the gib screws: central screw (6), adjacent screws, and then top and bottom screws. Finally, use the 8 mm combination wrench to tighten the nuts (7), while countering the set screws using the 2.5 mm hex wrench (8).

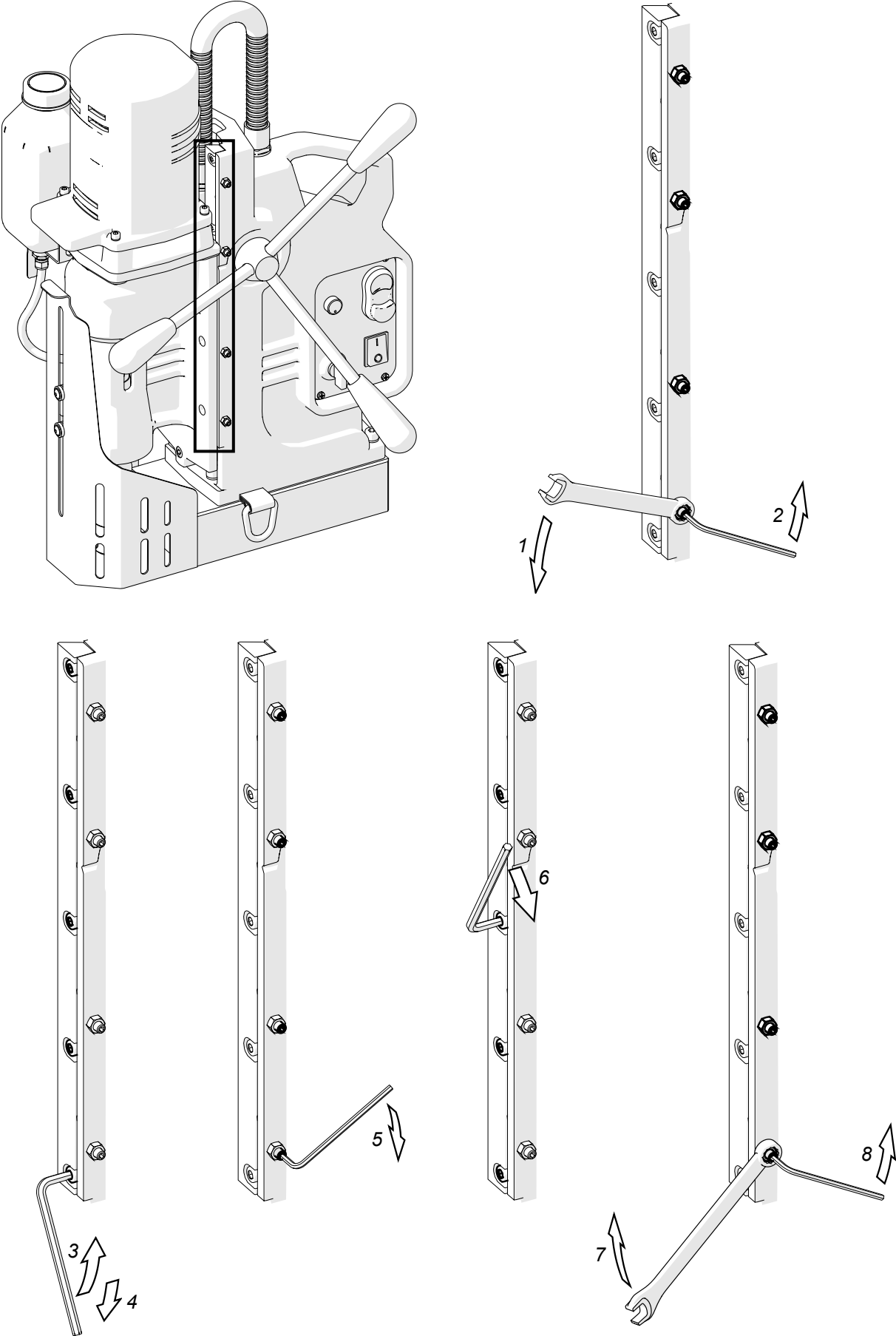

Fig. 11. Adjusting the gib clearance

3.11. Replacing the motor brushes

Check the condition of the carbon brushes every 100 operation hours. To do this, unplug the machine from the power source, use the 4 mm hex wrench to unscrew four screws (1, Fig. 12), and then remove the motor cover (2), paying attention to the ground wire 3 attached. Next, pry off the spring that holds the brush and rest the spring on the top of the brush holder (4). Unlock the connector by pressing it in the center (5), and then remove the connector (6) and the brush (7). If the length of the brush is less than 5 mm (0.2"), replace both brushes with new ones.

To install brushes, proceed in reverse order. After the replacement, run the motor without load for 20 minutes.

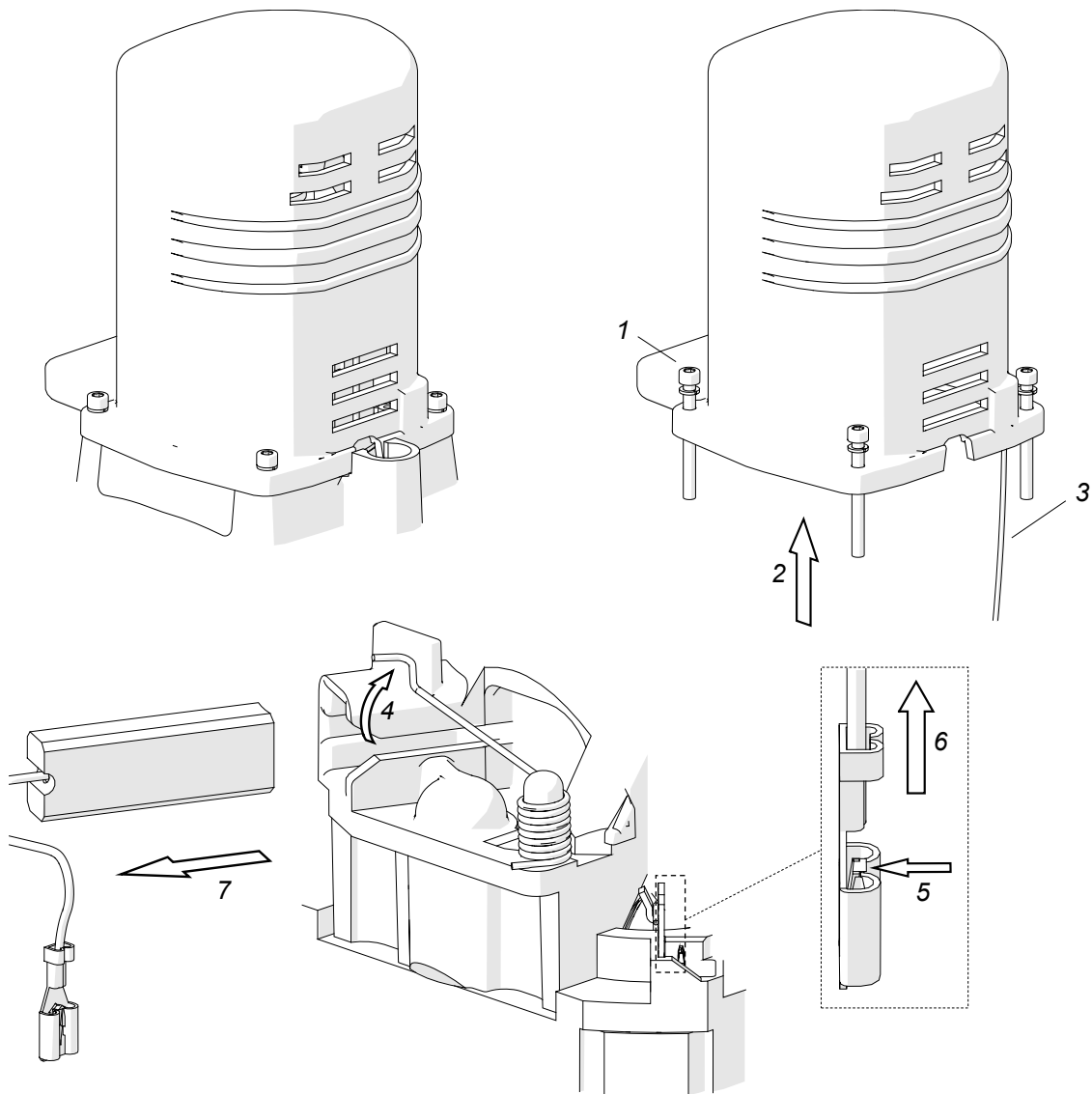
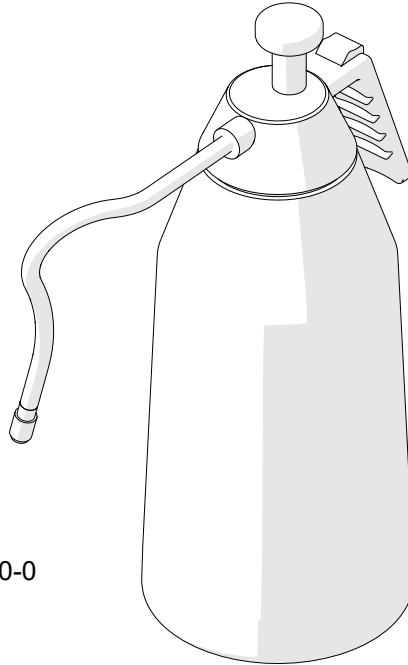

Fig. 12. Replacing the brushes

4. ACCESSORIES

4.1. Pressure cooling system

Capacity of 2 liters.



Part number:
UKL-0440-16-00-00-0

4.2. Arbor MT3 x 32 mm Weldon

Required when drilling diameter is more than 60 mm (2.3").

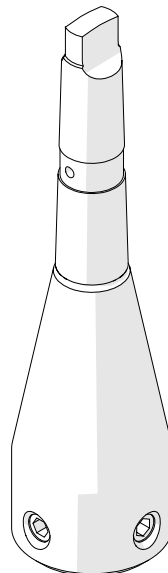

Part number:
UCW-0191-00-00-00-0

4.3. Quick change arbor MT3 x 19 mm Weldon

Part number:
UCW-0285-03-00-02-0

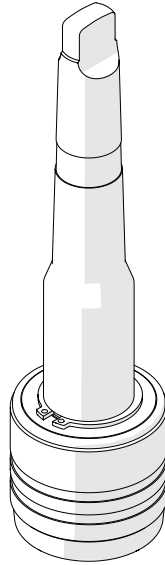

4.4. Pipe attachment DMP 501

Designed for pipes with diameters of 150–500 mm (6–20”).

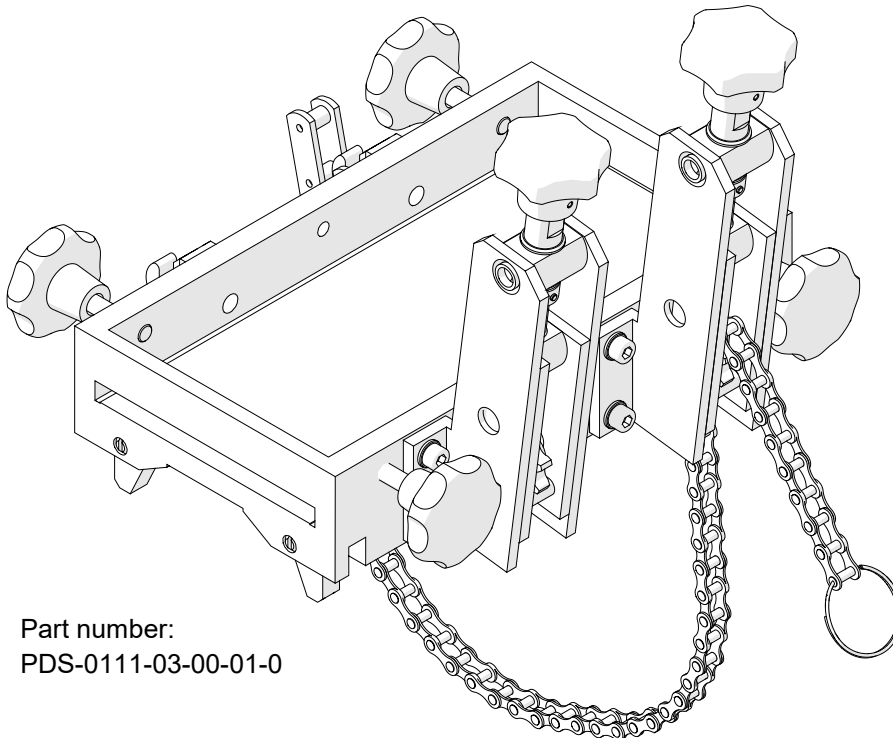

Part number:
PDS-0111-03-00-01-0

5. WIRING DIAGRAM

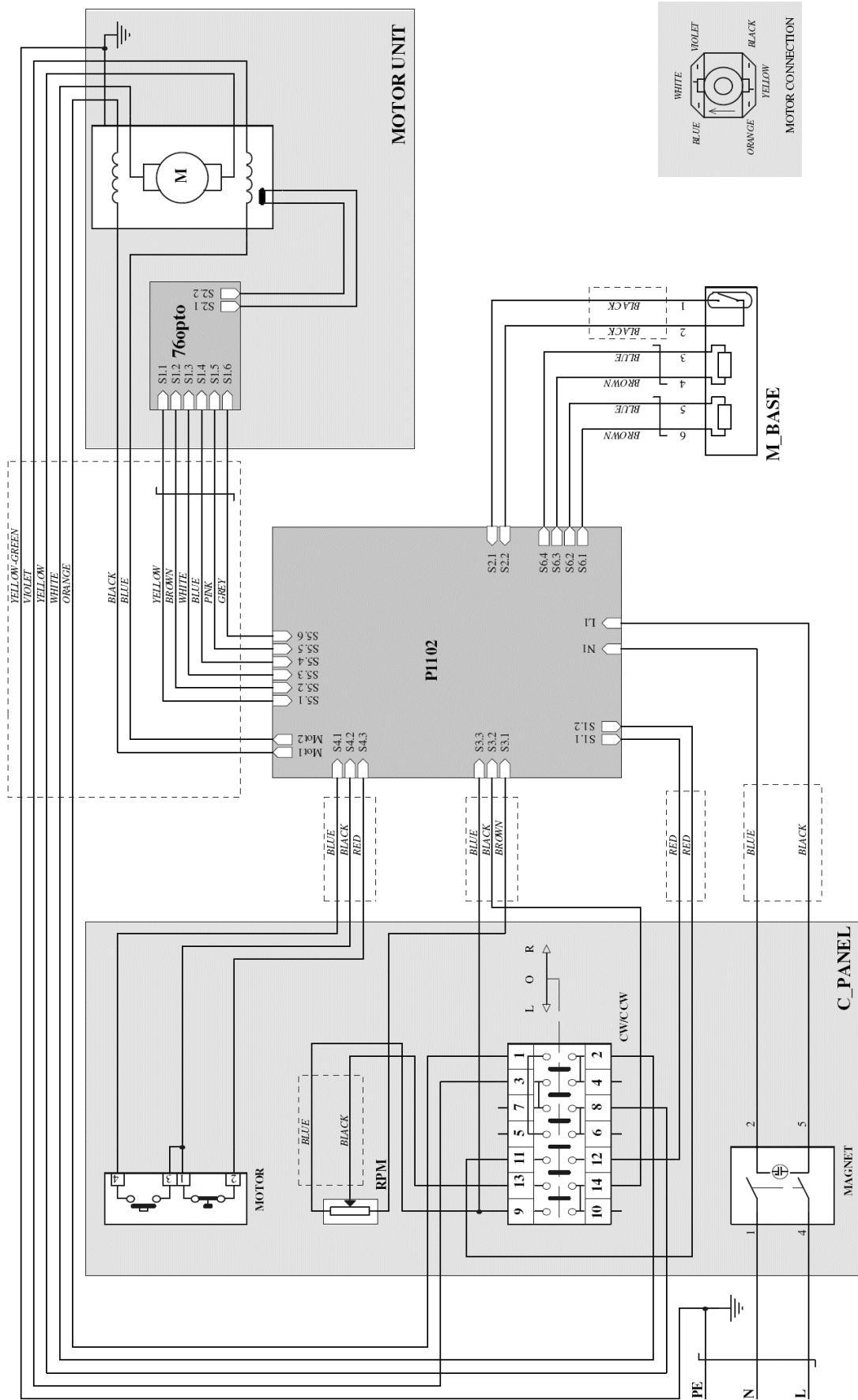

6. D3X RS EXPLODED DRAWINGS AND PARTS LIST

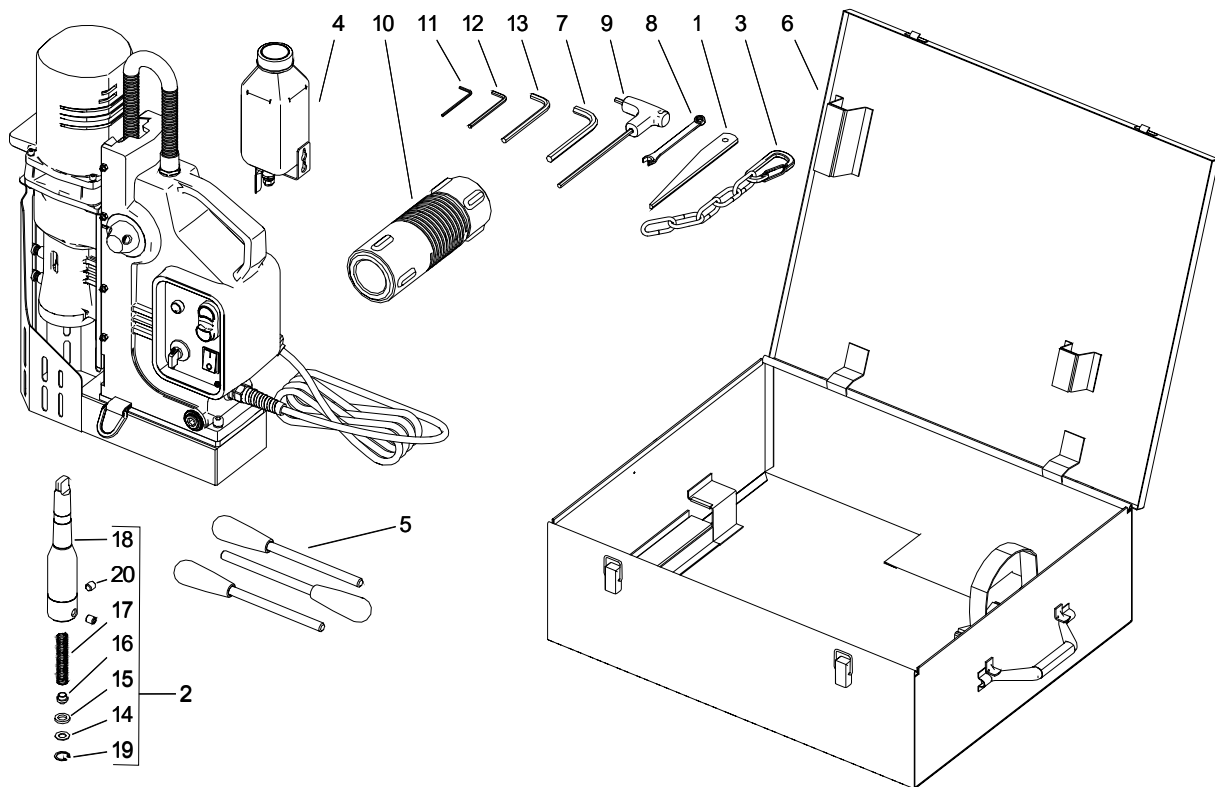

ITEM	PART NUMBER	DESCRIPTION	Q-TY
1	KLN-0103-00-00-00-0	WEDGE MT3	1
2	UCW-0173-00-00-00-0	ARBOR ASSY AMT3-U19/3-3	1
3	LNC-0223-00-01-00-0	SAFETY CHAIN 1.5 M (5 FT)	1
4	UKL-0399-11-00-00-0	COOLING SYSTEM	1
5	DZW-0400-07-00-00-0	SPOKE HANDLE ASSY	3
6	SKR-0400-12-00-00-1	METAL BOX	1
7	KLC-000004	10 MM HEX WRENCH	1
8	KLC-000003	8 MM COMBINATION WRENCH	1
9	KLC-000037	5 MM HEX WRENCH WITH HANDLE	1
10	OPK-000001	TOOL CAN	1
11	KLC-000005	2.5 MM HEX WRENCH	1
12	KLC-000007	4 MM HEX WRENCH	1
13	KLC-000009	6 MM HEX WRENCH	1
14	PDK-0139-00-04-00-0	WASHER 18.8x10x1	1
15	USZ-0140-05-04-00-0	SEAL	1
16	WYP-0154-00-02-00-0	PLUNGER	1
17	SPR-0154-00-03-00-0	SPRING 1.6x12.4x159	1
18	KRP-0173-00-01-00-0	ARBOR BODY	1
19	PRS-000009	INTERNAL RETAINING RING 19w	1
20	WKR-000032	HEX SOCKET SET SCREW WITH FLAT POINT M10x10	2

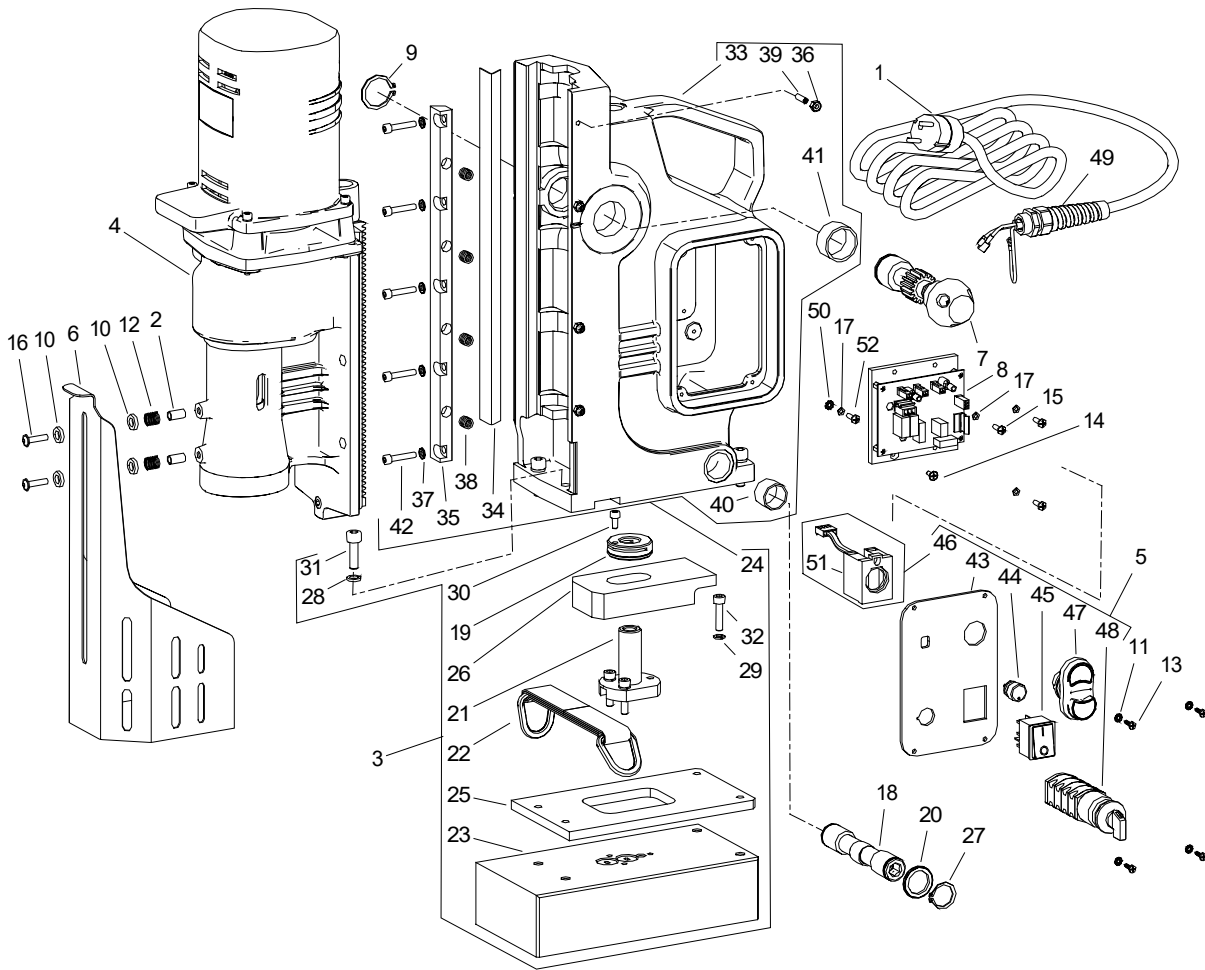

ITEM	PART NUMBER	DESCRIPTION	Q-TY
1	SZN-0212-10-02-00-2	POWER CORD 230V 3x1.5 WITH STRAIN RELIEF ASSY (EU)	1
1	SZN-0075-00-51-00-5	POWER CORD 120V 3x2.08 WITH STRAIN RELIEF ASSY (US)	1
1	SZN-0212-10-02-00-5	POWER CORD 230V 3x1.5 WITH STRAIN RELIEF ASSY (AU)	1
1	PWD-0212-10-02-00-6	POWER CORD 230V 3x1.5 WITH STRAIN RELIEF ASSY (INDIA)	1
2	TLJ-0399-06-00-00-0	BOTTOM SLEEVE	2
3	STJ-0473-01-00-00-1	FRAME ASSY	1
4	NPD-0473-02-00-00-1	DRIVE ASSY L-R – 230V	1
4	NPD-0473-02-00-00-0	DRIVE ASSY L-R – 120V	1
5	MSK-0473-03-00-00-0	PANEL PLATE ASSY	1
6	OSL-0400-04-00-00-0	GUARD ASSY	1
7	WLK-0400-05-00-00-0	PINION SHAFT ASSY	1
8	ZSP-0473-04-00-00-1	ELECTRONIC CONTROL SYSTEM – 230V	1
8	ZSP-0473-04-00-00-0	ELECTRONIC CONTROL SYSTEM – 115V	1
9	PRS-000019	EXTERNAL RETAINING RING 28z	1
10	PDK-000151	NYLON WASHER 8.1x14x3	4
11	PDK-000161	EXTERNAL TOOTH LOCK WASHER 3.7	4
12	SPR-000030	PUSH SPRING	2
13	WKR-000415	CROSS RECESSED PAN HEAD SELF-TAPPING SCREW 3.5x13	4
14	WKR-000150	CROSS RECESSED COUNTERSUNK HEAD SCREW M4x10	1
15	WKR-000184	CROSS RECESSED PAN HEAD SCREW M4x12	3
16	WKR-000395	HEX SOCKET ROUND HEAD SCREW WITH FLANGE M5x20	2
17	PDK-000043	SPRING WASHER 4.1	4

ITEM	PART NUMBER	DESCRIPTION	Q-TY
18	WLK-0153-02-04-00-0	ECCENTRIC SHAFT	1
19	NKR-0153-02-05-00-0	SPECIAL NUT	1
20	PDK-0153-02-06-00-0	SPECIAL WASHER 21.5x32x3	2
21	SRB-0165-01-03-00-0	SPECIAL BOLT	1
22	PAS-0205-00-20-00-1	D-RING STRAP – BLACK	1
23	PDS-0396-01-00-00-2	ELECTROMAGNETIC BASE	1
24	KRP-0473-01-01-00-1	BODY ASSY	1
25	PLY-0400-01-04-00-0	SWIVEL BASE PLATE	1
26	LPA-0400-01-05-00-0	PLATE CLAMPING ARM	1
27	PRS-000013	EXTERNAL RETAINING RING 21z	2
28	PDK-000051	SPRING WASHER 8.2	4
29	PDK-000046	SPRING WASHER 6.1	3
30	SRB-000075	HEX SOCKET HEAD CAP SCREW M5x10	1
31	SRB-000153	HEX SOCKET HEAD CAP SCREW M8x25	4
32	SRB-000115	HEX SOCKET HEAD CAP SCREW M6x25	3
33	KRP-0473-01-01-01-1	BODY	1
34	LST-0400-01-01-03-0	GIB	1
35	LST-0473-01-01-02-0	ADJUSTABLE GIB	1
36	NKR-000016	HEX NUT M5	4
37	PDK-000017	ROUND WASHER 5.3	5
38	SPR-000043	SPRING 1.6x8x14.5	4
39	WKR-000077	HEX SOCKET SET SCREW WITH FLAT POINT M5x16	4
40	TLJ-000014	SLIDE SLEEVE 21x24x16	2
41	TLJ-000010	SELF-LUBRICATING SLEEVE 28x32x16	2
42	SRB-000087	HEX SOCKET HEAD CAP SCREW M5x25	5
43	MSK-0473-03-01-00-0	PANEL PLATE	1
44	WZK-0400-03-03-00-0	ROTATIONAL SPEED WIRE SET	1
45	PNK-000013	MAGNET SWITCH	1
46	WZK-0400-03-02-00-0	START-STOP WIRE SET	1
47	PRC-000007	START-STOP SWITCH	1
48	WZK-0473-03-04-00-0	LEFT-RIGHT SWITCH WIRE SET	1
49	DLW-000007	CABLE GLAND WITH STRAIN RELIEF PG11	1
50	PDK-000060	EXTERNAL TOOTH LOCK WASHER 4.3	1
51	BLO-000023	START-STOP CONTACT BLOCK	1
52	WKR-000193	CROSS RECESSED PAN HEAD SCREW M4x8	1

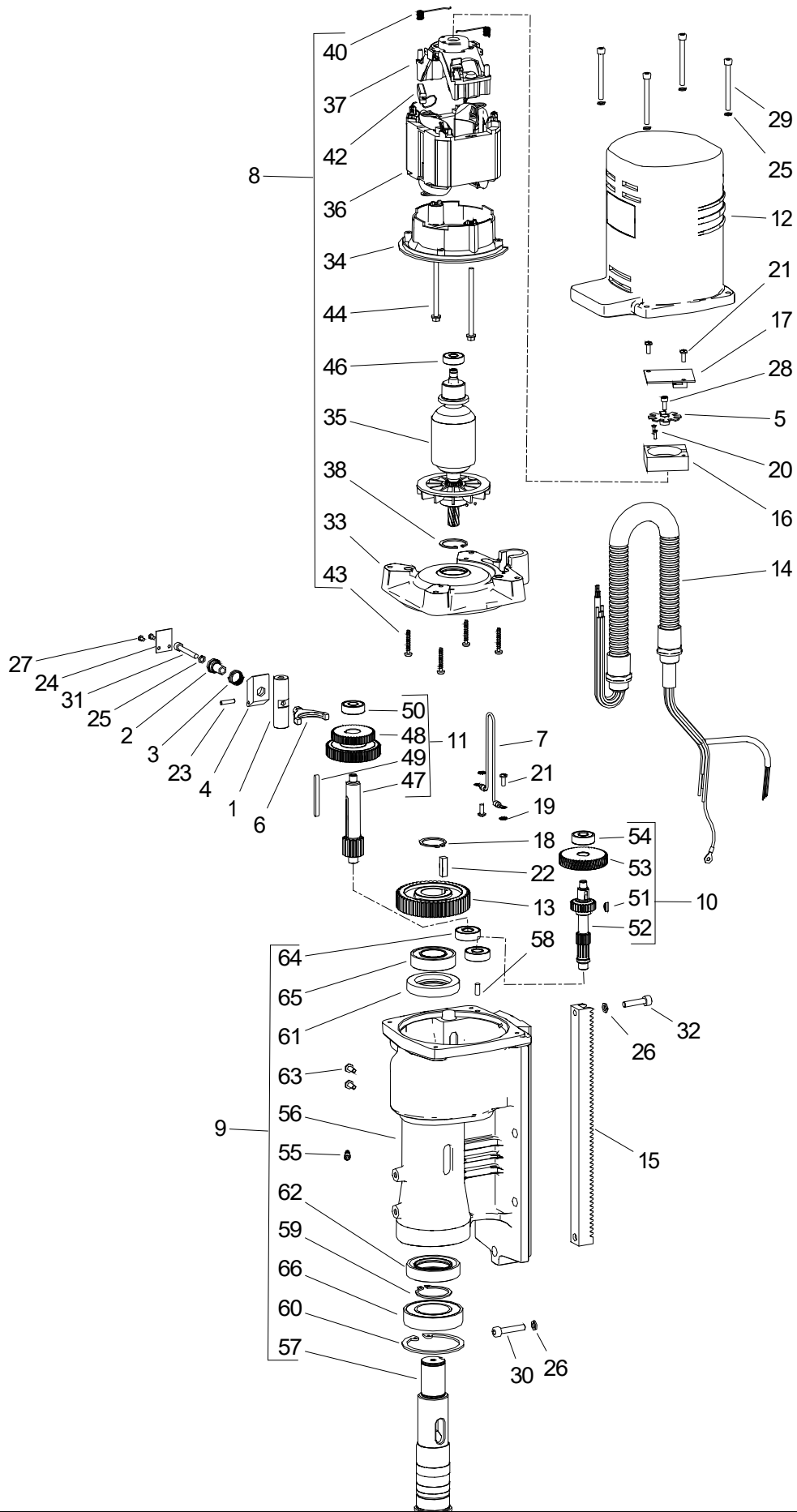

NPD-0473-02-00-00-1		DRIVE ASSY L-R – 230V	
NPD-0473-02-00-00-0		DRIVE ASSY L-R – 120V	
ITEM	PART NUMBER	DESCRIPTION	Q-TY
1	WLK-0171-00-21-00-2	LINK SHAFT	1
2	TLJ-0171-00-22-00-0	SWITCH SLEEVE	1
3	SPR-0171-00-23-00-0	SWITCH SPRING	1
4	DZW-0171-00-24-00-0	SHIFT LEVER	1
5	TRC-0171-05-00-00-0	PULSE DISK ASSY	1
6	WDL-0211-00-28-00-1	SHIFT FORK	1
7	PWD-0399-02-07-00-0	DRIVE GROUND WIRE	1
8	SLN-0473-02-01-00-1	MOTOR L-R ASSY 230V	1
8	SLN-0473-02-01-00-0	MOTOR L-R ASSY 120V	1
9	KRP-0400-02-02-00-0	GEARBOX BODY ASSY	1
10	WLK-0400-02-02-10-0	PINION SHAFT z12, m=1, z24, m=1 ASSY	1
11	WLK-0400-02-02-20-0	PINION SHAFT z12, m=1.5 ASSY	1
12	OBD-0400-02-03-00-1	MOTOR HOUSING	1
13	KOL-0400-02-04-00-0	GEAR z50	1
14	WZK-0473-02-05-00-0	MOTOR WIRE ASSY	1
15	LST-0400-02-06-00-0	GEAR RACK	1
16	KRP-0400-02-07-00-0	ENCODER BODY	1
17	MDL-0400-02-08-00-0	ENCODER MODULE	1
18	PRS-000017	EXTERNAL RETAINING RING 25z	1
19	PDK-000060	EXTERNAL TOOTH LOCK WASHER 4.3	2
20	WKR-000458	SCREW FOR PLASTIC 2.2x8	2
21	WKR-000183	CROSS RECESSED PAN HEAD SCREW M4x10	4
22	WPS-000054	KEY 6x6x20	1
23	KLK-000013	SPRING DOWEL PIN 4x16	1
24	TBL-0202-00-30-00-0	GEAR PLATE	1
25	PDK-000045	SPRING WASHER 5.1	5
26	PDK-000046	SPRING WASHER 6.1	2
27	WKR-000180	CROSS RECESSED PAN HEAD SCREW M3x5	2
28	SRB-000254	HEX SOCKET HEAD CAP SCREW M4x10	1
29	SRB-000094	HEX SOCKET HEAD CAP SCREW M5x50	4
30	SRB-000118	HEX SOCKET HEAD CAP SCREW M6x30	1
31	SRB-000091	HEX SOCKET HEAD CAP SCREW M5x35	1
32	SRB-000115	HEX SOCKET HEAD CAP SCREW M6x25	1
33	PKR-0473-02-01-10-1	MOTOR COVER	1
34	KRW-0400-02-01-02-0	FAN GUIDE	1
35	WRN-0473-02-01-20-1	ROTOR ASSY – 230V	1
35	WRN-0473-02-01-20-0	ROTOR ASSY – 120V	1
36	STN-000029	STATOR – 230V	1
36	STN-000028	STATOR – 120V	1
37	OBD-000024	UPPER HOUSING	1
38	PRS-000018	INTERNAL RETAINING RING 28w	1
40	SPR-000042	BRUSH SPRING	2
42	SCZ-000033	BRUSH – 230V	2
42	SCZ-000034	BRUSH – 115V	2
43	WKR-000524	TORX PAN HEAD TAPPING SCREW 4x25	4
44	SRB-000286	HEXAGON BOLT M5x76	2
46	LOZ-000055	BALL BEARING 8x22x7	1

NPD-0473-02-00-00-1		DRIVE ASSY L-R – 230V	
NPD-0473-02-00-00-0		DRIVE ASSY L-R – 120V	
ITEM	PART NUMBER	DESCRIPTION	Q-TY
47	WLK-0400-02-02-21-0	PINION SHAFT z12, m=1.5	1
48	KOL-0400-02-02-22-0	MOVABLE WHEEL z=43	1
49	WPS-000055	KEY 4x4x45	1
50	LOZ-000071	BALL BEARING 8x24x8	1
51	WPS-0211-00-17-00-1	KEY 3x3.7	1
52	WLK-0400-02-02-11-0	PINION SHAFT z12, m=1, z24, m=1	1
53	KOL-0400-02-02-12-1	HELICAL INPUT GEAR z47, m=1, m=17	1
54	LOZ-000071	BALL BEARING 8x24x8	1
55	KNC-0234-00-10-00-0	HOSE FITTING	1
56	KRP-0400-02-02-01-1	GEARBOX BODY	1
57	WRZ-0400-02-02-02-0	SPINDLE	1
58	KLK-000045	DOWEL PIN 5n6x12	1
59	PRS-000024	EXTERNAL RETAINING RING 35z	1
60	PRS-000035	INTERNAL RETAINING RING 62w	1
61	PRS-000077	SEAL 35x55x10	1
62	PRS-000081	SEAL 35x56x12	1
63	WKR-000450	CROSS RECESSED PAN HEAD SCREW M5x10	2
64	LOZ-000034	BALL BEARING 10x26x8	2
65	LOZ-000028	BALL BEARING 25x47x12	1
66	LOZ-000051	BALL BEARING 35x62x14	1
–	SMR-000001	GREASE LUBRIPLATE BP1	0.48 kg

7. DECLARATION OF CONFORMITY

EC Declaration of Conformity

We

***PROMOTECH sp. z o.o.
ul. Elewatorska 23/1
15-620 Białystok
Poland***

declare with full responsibility that:

D3X RS Drilling Machine with Electromagnetic Base

is manufactured in accordance with the following standards:

- EN 50144-1
- EN 55014

and satisfies safety regulations of the guidelines: 2004/108/EC, 2006/95/EC, 2006/42/EC.

Białystok, 26 July 2012



Marek Siergiej
CEO

8. QUALITY CERTIFICATE

Machine control card

Drilling Machine with Electromagnetic Base

- D3X RS 115 V**
- D3X RS 230 V**

Serial number

Spindle radial runout.....

Slide to base travel perpendicularity.....

Spindle axis to base perpendicularity

Base holding force

(surface with the thickness of 22 mm and roughness $R_a \leq 1.25$)

Electric test

Type of test	Result	Name of tester
Test with sinusoidal voltage (voltage 1000 V, frequency 50 Hz)	 Date
Resistance of the protective circuit Ω Signature

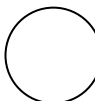
Quality control 

Adjustments, inspections

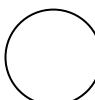
Quality control 

9. WARRANTY CARD

WARRANTY CARD No.....

..... in the name of Manufacturer warrants the D3X RS Drilling Machine with Electromagnetic Base to be free of defects in material and workmanship under normal use for a period of 12 months from the date of sale.

This warranty does not cover tools as well as damage or wear that arise from misuse, accident, tempering, or any other causes not related to defects in workmanship or material.

Date of production

Serial number

Date of sale

Signature of seller.....

1.06 / 31 October 2018

WE RESERVE THE RIGHT TO MAKE CHANGES IN THIS MANUAL WITHOUT NOTICE

3/4" SHANK M2AL ANNULAR CUTTERS			
		1" D.O.C.	2" D.O.C.
M2AL Cutter Diameter	DECIMAL EQUIVALENT	PART#	PART#
7/16"	0.4375	SM-AC-0438-1	SM-AC-0438-2
1/2"	0.5000	SM-AC-0500-1	SM-AC-0500-2
9/16"	0.5625	SM-AC-0563-1	SM-AC-0563-2
5/8"	0.6250	SM-AC-0625-1	SM-AC-0625-2
11/16"	0.6875	SM-AC-0688-1	SM-AC-0688-2
3/4"	0.7500	SM-AC-0750-1	SM-AC-0750-2
13/16"	0.8125	SM-AC-0813-1	SM-AC-0813-2
7/8"	0.8750	SM-AC-0875-1	SM-AC-0875-2
15/16"	0.9375	SM-AC-0938-1	SM-AC-0938-2
1"	1.0000	SM-AC-1000-1	SM-AC-1000-2
1-1/16"	1.0620	SM-AC-1063-1	SM-AC-1063-2
1-1/8"	1.1250	SM-AC-1125-1	SM-AC-1125-2
1-3/16"	1.1870	SM-AC-1188-1	SM-AC-1188-2
1-1/4"	1.2500	SM-AC-1250-1	SM-AC-1250-2
1-5/16"	1.3120	SM-AC-1313-1	SM-AC-1313-2
1-3/8"	1.3750	SM-AC-1375-1	SM-AC-1375-2
1-7/16"	1.4370	SM-AC-1438-1	SM-AC-1438-2
1-1/2"	1.5000	SM-AC-1500-1	SM-AC-1500-2
1-9/16"	1.5620	SM-AC-1563-1	SM-AC-1563-2
1-5/8"	1.6250	SM-AC-1625-1	SM-AC-1625-2
1-11/16"	1.6870	SM-AC-1688-1	SM-AC-1688-2
1-3/4"	1.7500	SM-AC-1750-1	SM-AC-1750-2
1-13/16"	1.8120	SM-AC-1813-1	SM-AC-1813-2
1-7/8"	1.8750	SM-AC-1875-1	SM-AC-1875-2
1-15/16"	1.9370	SM-AC-1938-1	SM-AC-1938-2
2"	2.0000	SM-AC-2000-1	SM-AC-2000-2
2-1/16"	2.0620	SM-AC-2063-1	SM-AC-2063-2
2-1/8"	2.1250	SM-AC-2125-1	SM-AC-2125-2
2-3/16"	2.1870	SM-AC-2188-1	SM-AC-2188-2
2-1/4"	2.2500	SM-AC-2250-1	SM-AC-2250-2
2-5/16"	2.3120	SM-AC-2313-1	SM-AC-2313-2
2-3/8"	2.3750	SM-AC-2375-1	SM-AC-2375-2
14mm	0.5512	SM-AC-14-M-1	SM-AC-14-M-2
15mm	0.5906	SM-AC-15-M-1	SM-AC-15-M-2
16mm	0.6299	SM-AC-16-M-1	SM-AC-16-M-2
17mm	0.6693	SM-AC-17-M-1	SM-AC-17-M-2
18mm	0.7087	SM-AC-18-M-1	SM-AC-18-M-2
19mm	0.7480	SM-AC-19-M-1	SM-AC-19-M-2
20mm	0.7874	SM-AC-20-M-1	SM-AC-20-M-2
21mm	0.8268	SM-AC-21-M-1	SM-AC-21-M-2
22mm	0.8661	SM-AC-22-M-1	SM-AC-22-M-2
23mm	0.9055	SM-AC-23-M-1	SM-AC-23-M-2
24mm	0.9449	SM-AC-24-M-1	SM-AC-24-M-2
25mm	0.9843	SM-AC-25-M-1	SM-AC-25-M-2
26mm	1.0230	SM-AC-26-M-1	SM-AC-26-M-2
28mm	1.1020	SM-AC-28-M-1	SM-AC-28-M-2
29mm	1.1410	SM-AC-29-M-1	SM-AC-29-M-2
31mm	1.2200	SM-AC-31-M-1	SM-AC-31-M-2