



The tools of innovation.

OPERATOR'S MANUAL

Torch Runner (HS)

CUTTING CARRIAGE

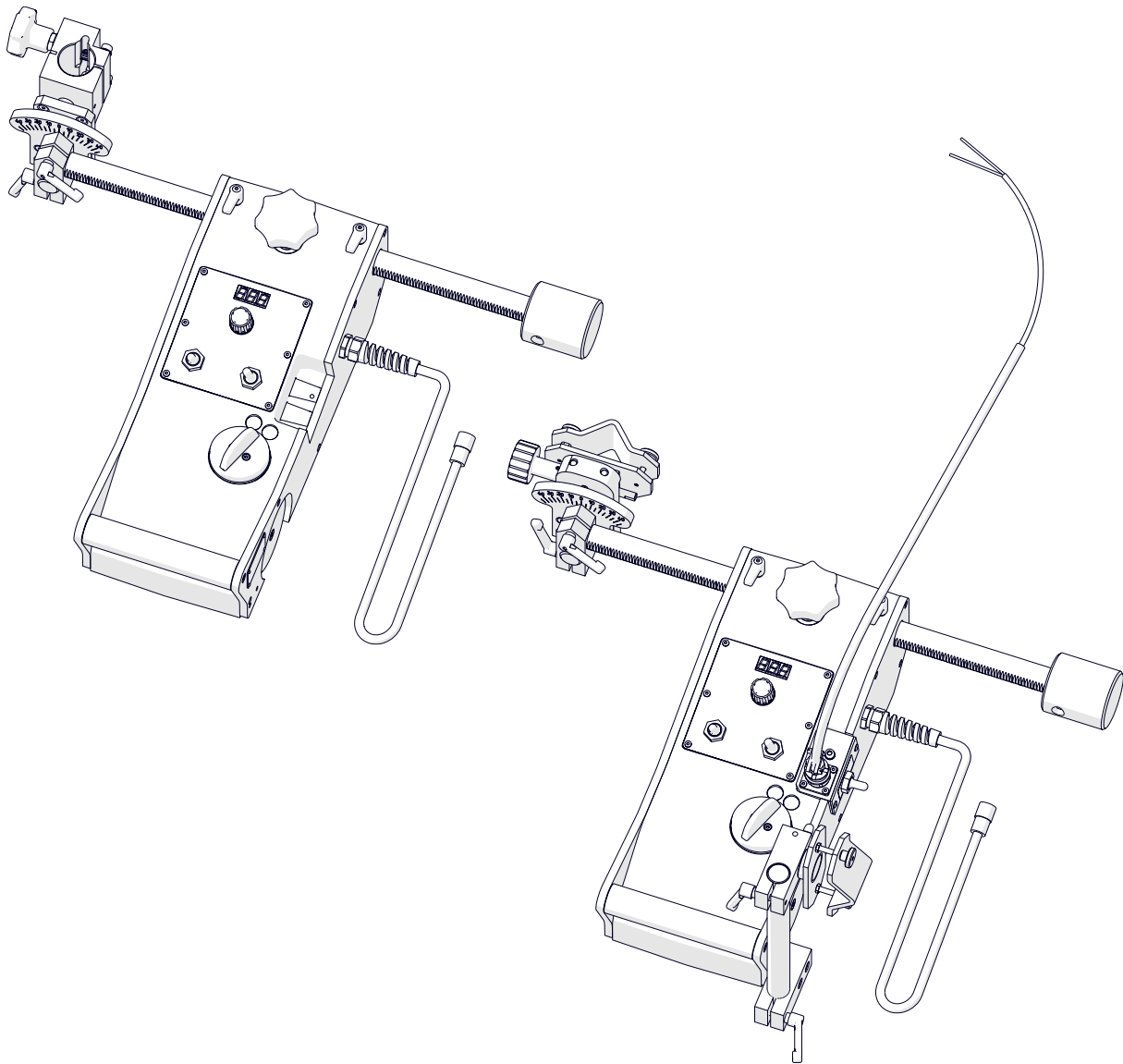

112 Inverness Circle East Suite F Englewood, CO 80112

1-87STEELMAX, FAX 303-690-9172

www.steelmax.com sales@steelmax.com

Contents

1. GENERAL INFORMATION	3
1.1. Application	3
1.2. Technical data.....	3
1.3. Equipment included	3
1.4. Dimensions	5
1.5. Design	6
2. SAFETY PRECAUTIONS.....	7
3. STARTUP AND OPERATION	9
3.1. Preparing	9
3.2. Operating.....	10
3.3. Changing the unit of speed	11
3.4. Troubleshooting	12
4. MAINTENANCE	13
5. ACCESSORIES	14
5.1. Track.....	14
5.2. 1000 mm (39") rack	15
5.3. 2.6 kg (5.7 lbs) counterweight	16
5.4. Roller support	16
5.5. Cable anchor	17
5.6. Torch holders.....	17
5.7. Slide rack holder	19
5.8. Circle cutting attachments.....	21
5.9. Left and right heat protection shield	23
5.10. Bottom heat protection shield	23
5.11. Magnetic units	24
5.12. Vacuum track system	25
5.13. Gas manifold (for oxy-fuel cutting)	26
5.14. Gas manifold bracket (for oxy-fuel cutting).....	28
5.15. Arc ignition set (for plasma cutting).....	29
6. 115–230 V WIRING DIAGRAM	30
7. 115–230 V HS WIRING DIAGRAM	31
8. 115–230 V EXPLODED VIEWS AND PARTS LIST.....	32
9. 115–230 V HS EXPLODED VIEWS AND PARTS LIST.....	36
10. DECLARATION OF CONFORMITY	40
11. QUALITY CERTIFICATE.....	41
12. WARRANTY CARD.....	42

1. GENERAL INFORMATION

1.1. Application

The Torch Runner (HS) is a cutting carriage designed to cut steel by using oxy-fuel torches with the handle diameter of 35 mm (1.38") or plasma torches with the handle diameter of 28–35 mm (1.10–1.38"). The carriage travels horizontally on the workpiece or track tilted up to 10°.

Accessories allow, for example, using torches with different handle diameters, using two torches at the same time, and cutting holes with the radius of 240–2500 mm (0.8–8.2 ft).

1.2. Technical data

	Torch Runner	Torch Runner HS
Voltage	1~ 115–230 V, 50–60 Hz	1~ 115–230 V, 50–60 Hz
Power	20 W	20 W
Work position	Horizontal	Horizontal
Torch diameter	35 mm (1.38")	28–35 mm (1.10–1.38")
Ground clearance	8 mm (0.31")	8 mm (0.31")
Speed	0–150 cm/min (0–59 in/min)	10–300 cm/min (4–118 in/min)
Weight	16.8 kg (37 lbs)	16.8 kg (37 lbs)

1.3. Equipment included

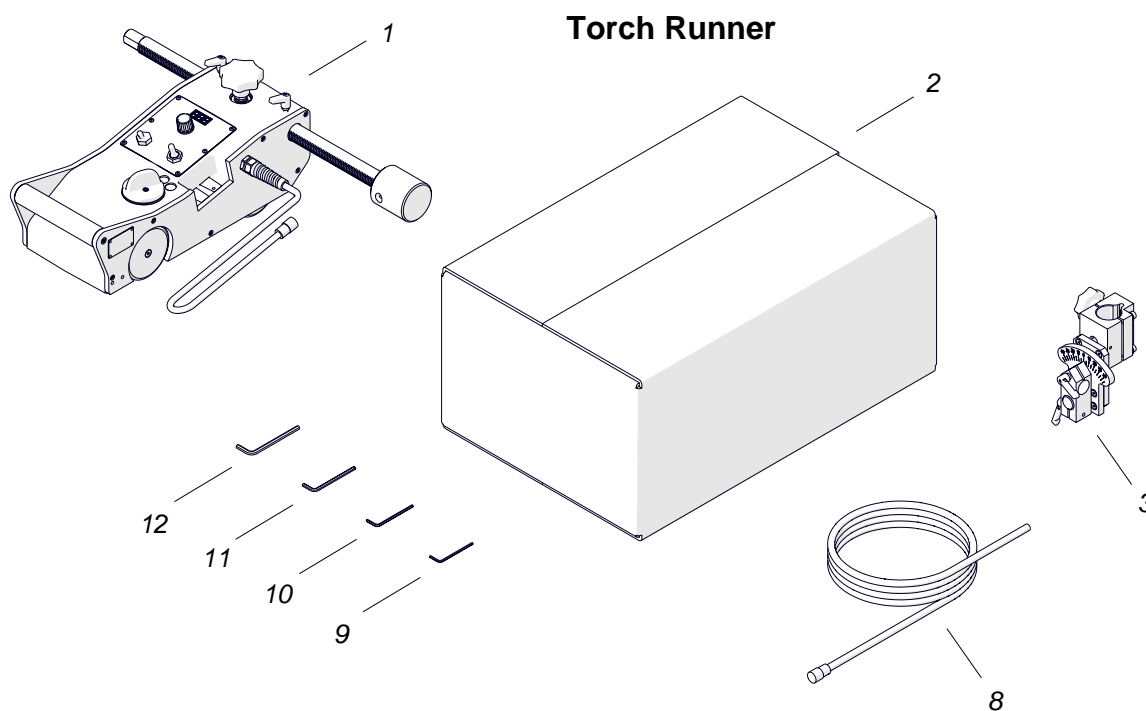

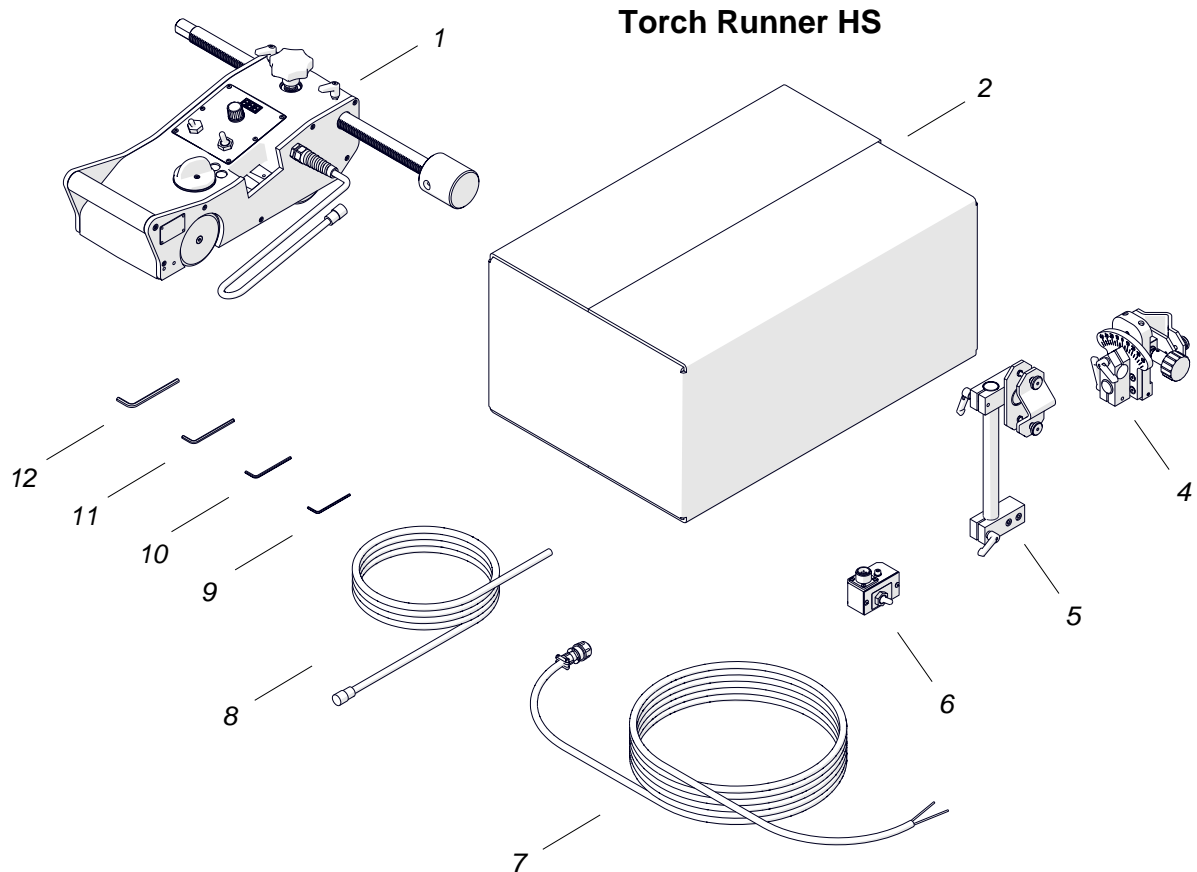

		Torch Runner	Torch Runner HS
1	Carriage	1 unit	1 unit
2	Foam-filled cardboard box	1 unit	1 unit
3	35 mm precise machine torch holder	1 unit	–
4	28–35 mm precise torch holder	–	1 unit
5	Cable anchor	–	1 unit
6	Arc ignition set	–	1 unit
7	6.5 m (21 ft) arc ignition cable	–	1 unit
8	3 m (10 ft) power cord	1 unit	1 unit
9	2.5 mm hex wrench	1 unit	1 unit
10	3 mm hex wrench	1 unit	1 unit
11	4 mm hex wrench	1 unit	1 unit
12	5 mm hex wrench	1 unit	1 unit
–	Operator's Manual	1 unit	1 unit

1.4. Dimensions

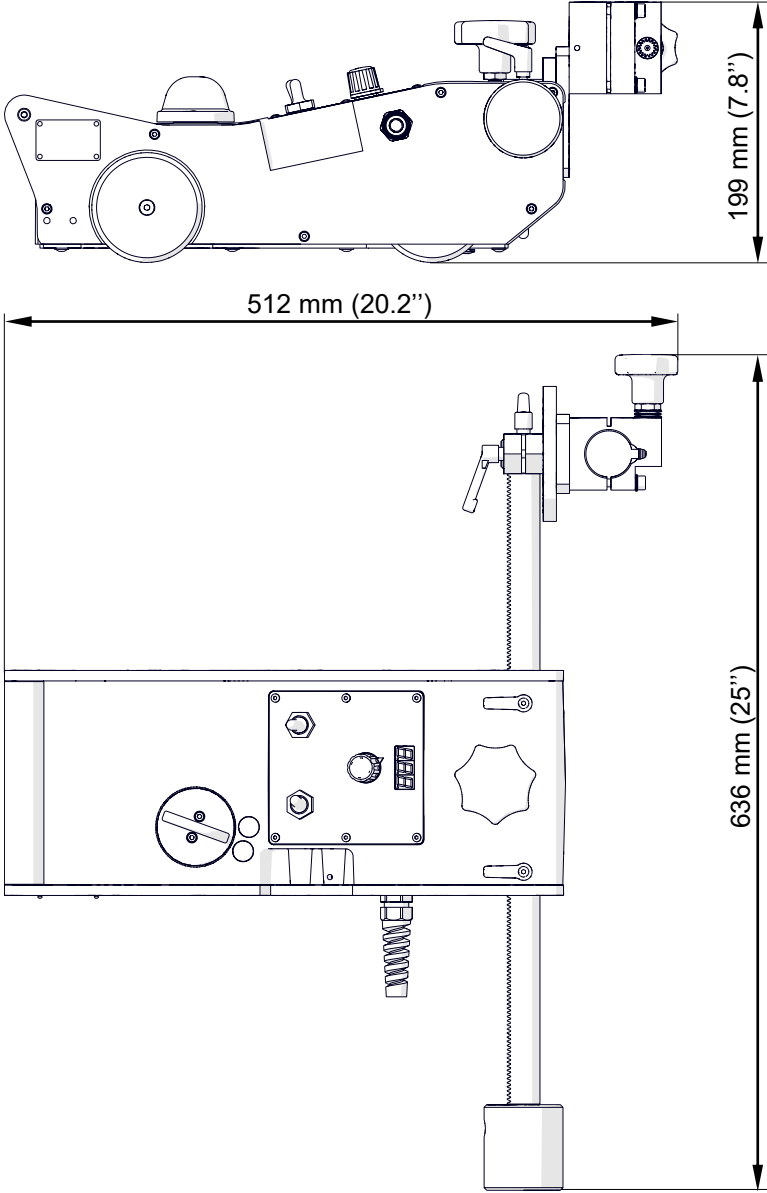

1.5. Design

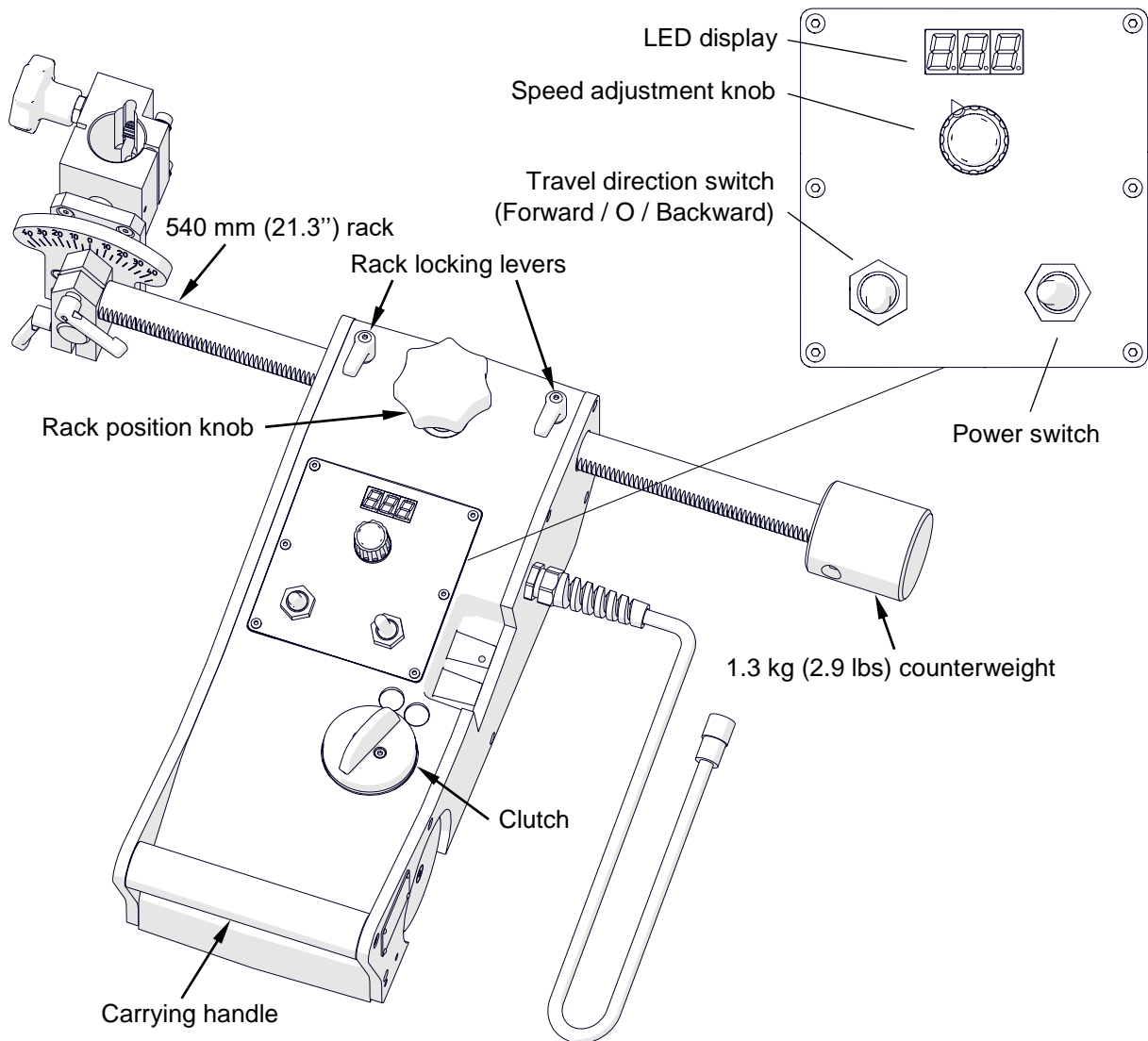

2. SAFETY PRECAUTIONS

1. Before starting, read this Operator's Manual and complete proper occupational safety and health training.
2. Use only in applications specified in this Operator's Manual.
3. The carriage must be complete and all parts must be genuine and fully functional.
4. The specifications of the power source must conform to those specified on the rating plate.
5. Connect the carriage into a properly grounded power source.
6. Never carry the carriage by the cords or arc ignition cable and never pull them because this may damage them and result in electric shock.
7. Untrained bystanders must not be present near the carriage.
8. Before starting, ensure the correct condition of the carriage, power source, power cords, arc ignition cable, plugs, and control panel.
9. Keep the carriage dry, and never expose it to rain, snow, or frost.
10. Keep the work area well lit, clean, and free of obstacles.
11. Never use near flammable liquids or gases, or in explosive environments.
12. Transport and position the carriage by using the carrying handle.
13. Do not stay below the carriage placed at heights.
14. Plug the cords and arc ignition cable into sockets only when the power switch is set to 'O'.
15. Keep the sockets clean. Do not use compressed air for cleaning.
16. Install only torches which handle diameter is the same as the diameter of the torch holder in use.
17. Keep the torch cables from coming in contact with the surface. They must be suspended to reduce the load of the carriage.
18. Use the torch according to the torch manual.
19. Use the carriage in horizontal positions only.
20. Always use eye protection (helmet, shield, and screen), hearing protection, gloves, and protective clothing during work. Do not wear loose clothing.
21. Before every use, inspect the carriage to ensure it is not damaged. Check whether any part is cracked or improperly fitted. Make sure to maintain proper conditions that may affect the operation of the carriage.

22. Never try to manually stop the travel. To stop, set the clutch to OFF or the travel direction switch to 'O'.
23. Maintain only when the carriage is unplugged from the power source.
24. Repair only in a service center appointed by the seller.
25. If the carriage falls from any height, is wet, or has any other damage that could affect the technical state of the carriage, stop the work and promptly send the carriage to the service center for inspection and repair.
26. Never leave the carriage unattended during work.
27. Remove from the worksite and store in a secure and dry place when not in use.

3. STARTUP AND OPERATION

3.1. Preparing

Before starting, clean the wheels of the carriage and remove the anti-corrosion coating from the track. Use the carrying handle to transport the carriage to the worksite. Set the power switch and the travel direction switch to 'O', and set the clutch to OFF. Then, plug the power cord into the power source and insert the torch into the torch holder (Fig. 1).

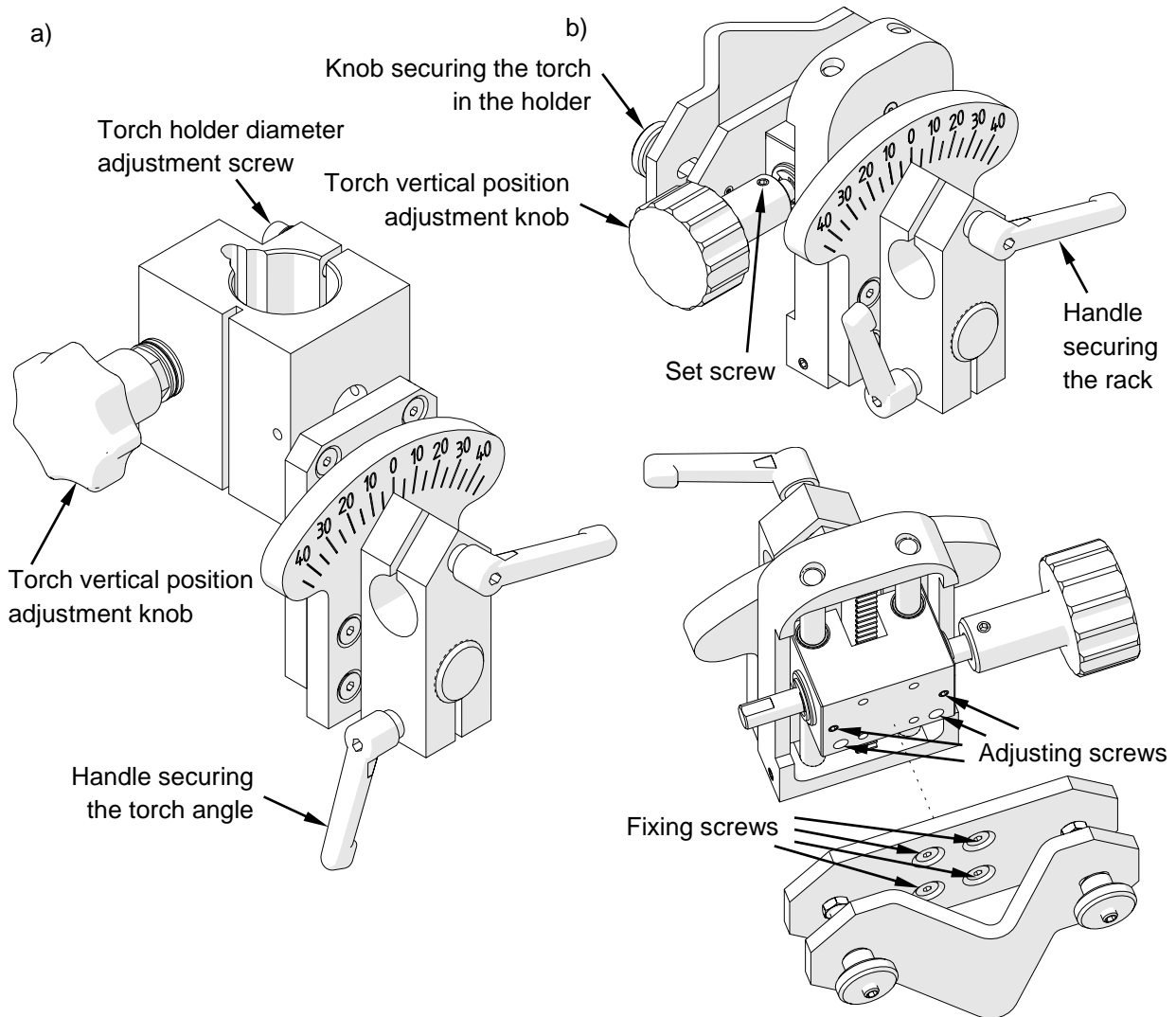

Fig. 1. Design of the precise machine torch holder for oxy-fuel cutting (a) and of the precise torch holder for plasma cutting (b)

The precise machine torch holder (Fig. 1a) allows torches with the handle diameter of 35 mm (1.38") equipped with a rack. Loosen the lower handle to precisely set the torch angle. Use the knob to adjust the vertical position of the torch.

The precise torch holder (Fig. 1b) is designed for torches with the handle diameter of 28–35 mm (1.10–1.38") and allows precise adjustment of the torch angle. The knob can be installed at either side after loosening the set screw and is used to adjust the vertical position of the torch. To adjust the resistance of the vertical move, use the 2.5 mm hex wrench and unscrew all fixing screws, and then use the 2 mm hex wrench and adjust the adjusting screws.

Use the rack position knob to adjust the horizontal position of the torch, and use the rack locking levers to lock the rack in position.

Then, connect the torch to a proper gas source. Depending on the cutting method (oxy-fuel or plasma) install into the carriage slot either a gas manifold or the arc ignition set in the manner described in the subsection of the respective accessory.

Position the carriage on the workpiece or track so that the torch is placed right above the starting point of the cut. Then, set the clutch to ON.

3.2. Operating

Set the power switch to 'I' to turn on the power, which will light all parts of the display (888). Then, the *EUR* appears if the unit of speed is set to centimeters per minute, or *USA* for inches per minute. Next, the carriage speed appears. The speed can be changed by rotating the knob on the panel. If needed, set the clutch to OFF and travel the carriage manually.

To start the cutting, light the torch as described in the torch manual. Adhere to all rules included in the torch manual.

Use the travel direction switch to select a direction of travel. Then, the real speed of the carriage appears on the display. To stop the travel, set the travel direction switch to 'O' or the clutch to OFF. To extinguish the torch flame, proceed as described in the torch manual.

After the work is finished, use the power switch to turn off the power and unplug the carriage from the power source. Clean the teeth of the rack once a week.

3.3. Changing the unit of speed

To change the unit of speed between centimeters per minute and inches per minute, unplug the carriage from the power source and follow the steps shown in Fig. 2.

After the unit is changed and the carriage powered, the current unit of measure appears. When the jumper cap connects the left and center pin, the display shows *EUR* and the speed is given in centimeters per minute. When the jumper cap connects the center and right pin, the display shows *USA* and the speed is given in inches per minute. The 2.5 mm hex wrench needed to unscrew the control panel is not included in standard equipment.

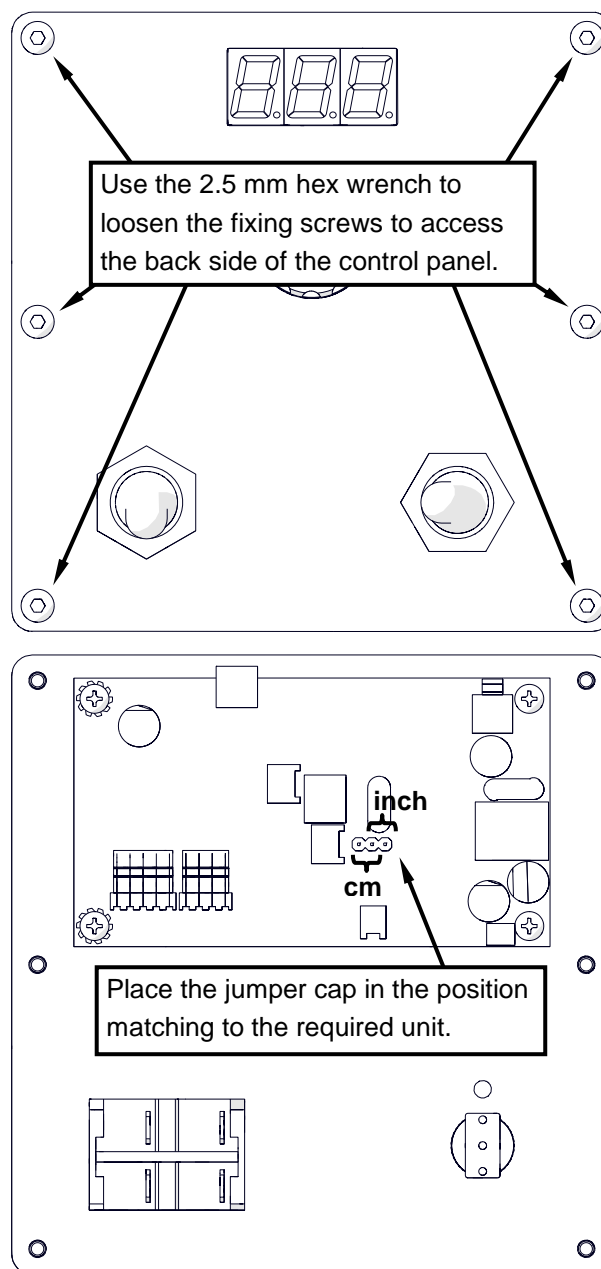

Fig. 2. Changing the unit of speed

3.4. Troubleshooting

Message	Problem	Solution
0.55.	Not all display segments lit after powering indicate a problem with the display or controller.	Contact service center for inspection and repair.
EUR	Speed displayed in centimeters per minute instead of inches per minute.	Follow instructions given in the section "Changing the unit of speed."
USA	Speed displayed in inches per minute instead of centimeters per minute.	Follow instructions given in the section "Changing the unit of speed."
Er.5.	<p>1. Travel direction switch not set to 'O' when powering.</p> <p>2. Displayed during travel indicates a malfunction of the travel direction switch or travel direction identification circuit of the controller.</p>	<p>1. Set the travel direction switch to 'O'. If the message still appears, contact service center for inspection and repair.</p> <p>2. Contact service center for inspection and repair.</p>
erL	Motor overload (safe current level exceeded) that promptly stops the carriage.	<p>Adjust the arrangement of the cables that block the travel and remove any other elements that block the carriage or its wheels.</p> <p>If this message still appears, contact service center for inspection and repair.</p>

4. MAINTENANCE

Daily:

1. Clean the wheels.
2. Clean the torch nozzle. Replace if damaged.

Monthly:

1. Check whether the knob and switches work as intended. Replace if loose or damaged.
2. Inspect cables, cords, and hoses. Replace if damaged.
3. Tighten screws if loose.

5. ACCESSORIES

5.1. Track

Increases the cutting precision by forcing straight-line travel. The length of a single rail is 1800 mm (70.9") and the V-groove centerline is 152 mm (6"). To connect two rails, use the 4 mm hex wrench, connecting plate, M5x6 screws, and 5.3 mm washers as shown in the figure below.

Part number:
TRO-0475-13-00-00-0

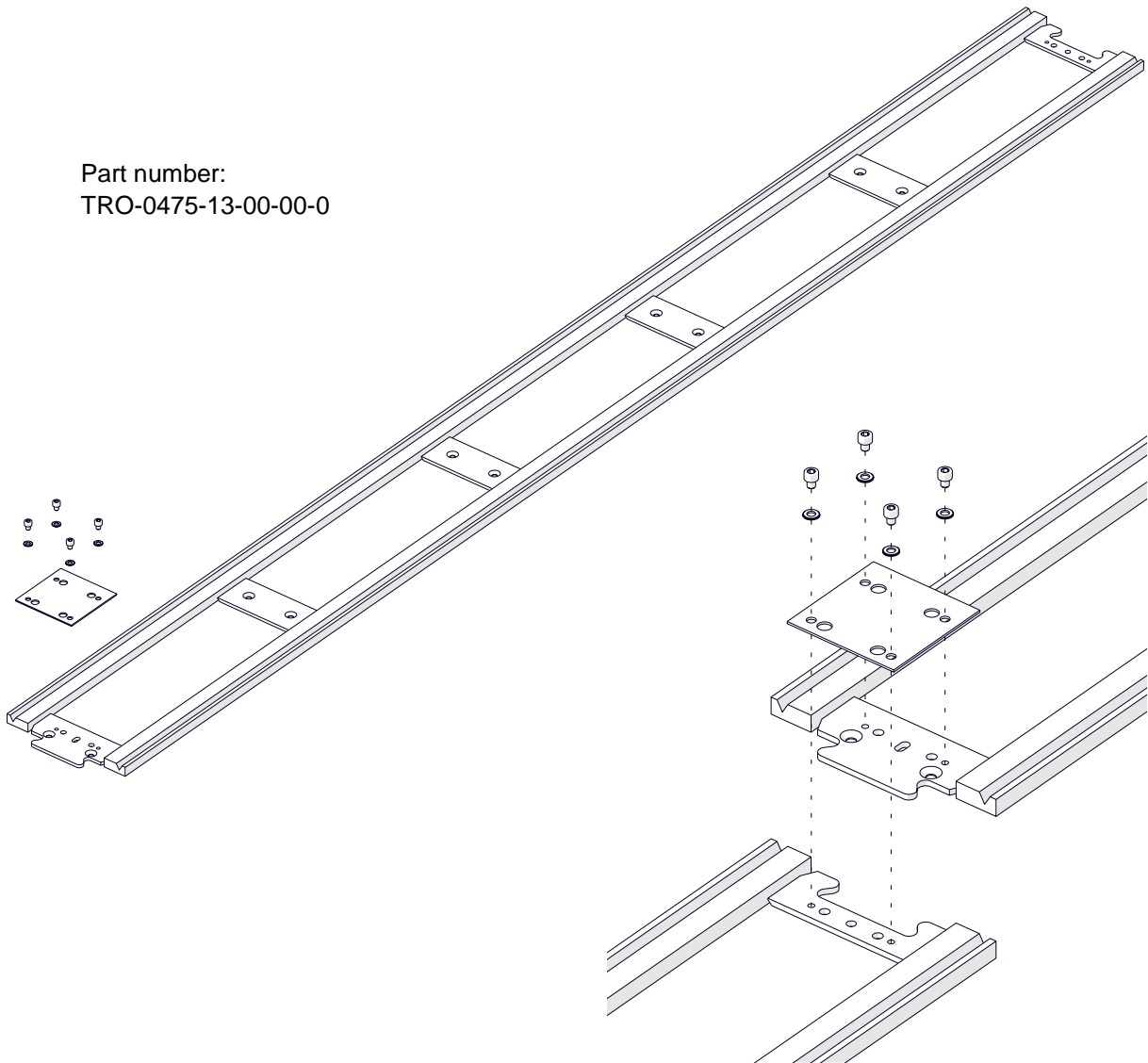

5.2. 1000 mm (39") rack

Increases the reach of the torch holder.

Part number:
RAM-0475-23-00-00-0

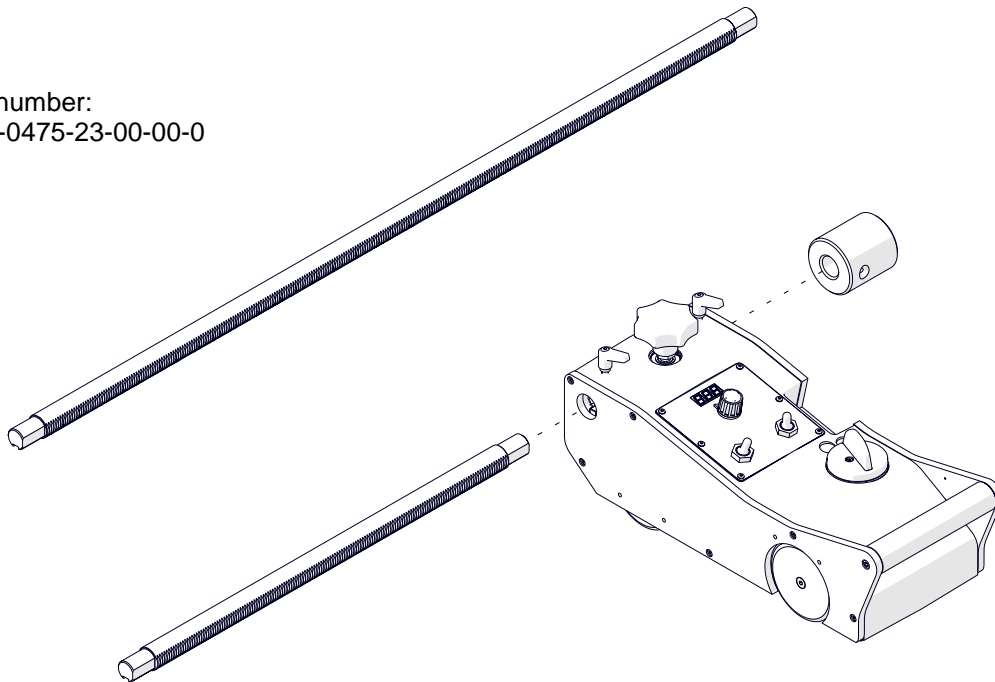

To remove the installed rack, use the 3 mm hex wrench to loosen the set screw and remove the counterweight. Then, loosen the handle of the torch holder and remove the holder. Next, unlock two rack locking levers and rotate the rack position knob to move the rack out of the carriage body. Install in reverse order. Position the rack teeth sideways to engage them with the gear of the knob. Note that using the 1000 mm (39") rack may also require the roller support or 2.6 kg counterweight to balance the carriage.

5.3. 2.6 kg (5.7 lbs) counterweight

Provides balance when using additional holders, 1000 mm (39") rack, or heavier torch. To remove the counterweight, use the 3 mm hex wrench to loosen the set screw. Install in reverse order.

Part number:
PWG-0475-10-00-00-0

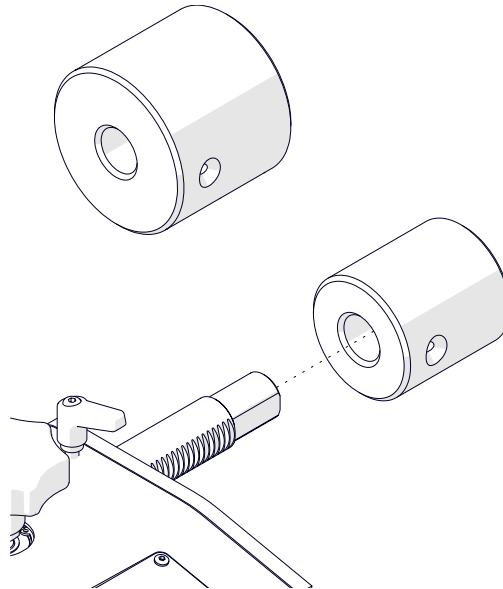

5.4. Roller support

Provides balance when using the 1000 mm (39") rack or a heavier torch.

Part number:
PDT-0475-26-00-00-0

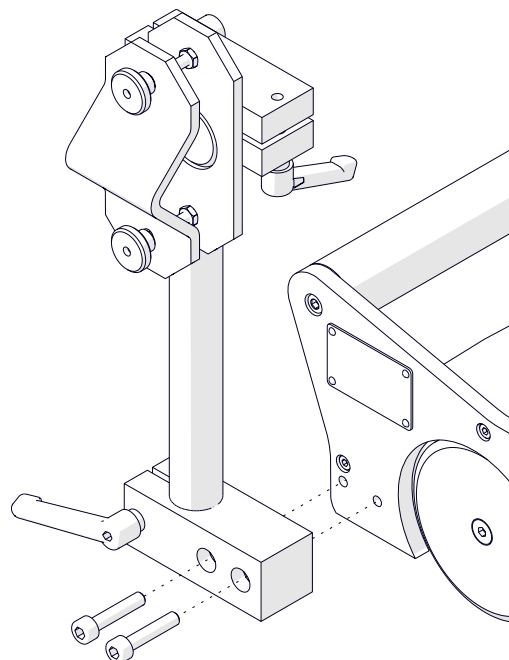

To install, loosen the handle of the torch holder and remove the holder. Then, place the support onto the rack, secure with the handle, and reinstall the holder.

5.5. Cable anchor

Anchors gas cables and power cord to relieve stress for the torch holder. Install the anchor to the side wall with the 5 mm hex wrench and two M6x30 screws.

Part number:
PDT-0475-34-00-00-0

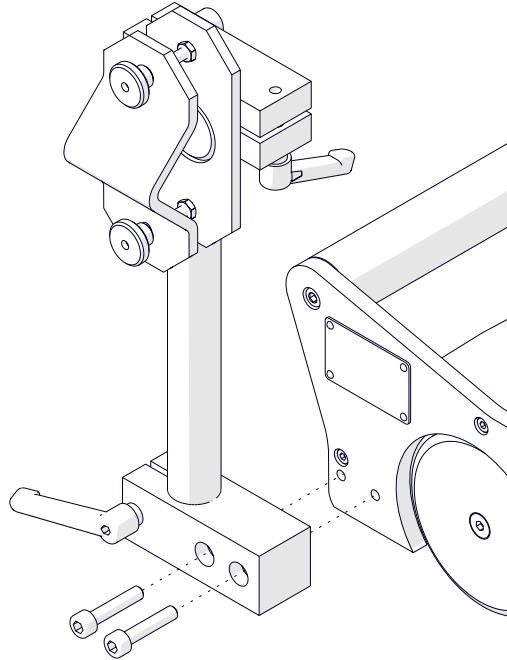

5.6. Torch holders

5.6.1. Standard torch holder

Designed for torches with the handle diameter of 28–35 mm (1.10–1.38”) and allows rough adjustment of the torch angle.

Part number:
UCW-0475-28-00-00-0

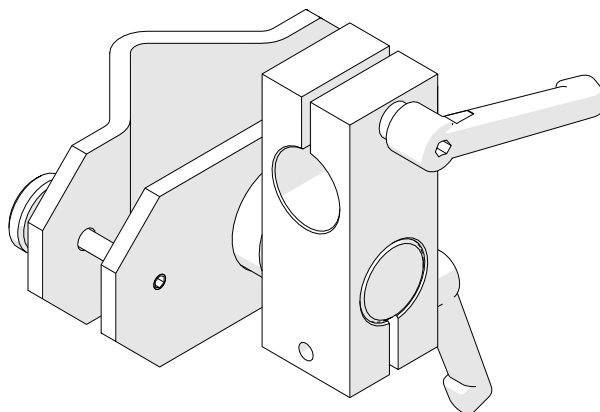

5.6.2. Precise torch holder

Designed for torches with the handle diameter of 28–35 mm (1.10–1.38”) and allows precise adjustment of the torch angle.

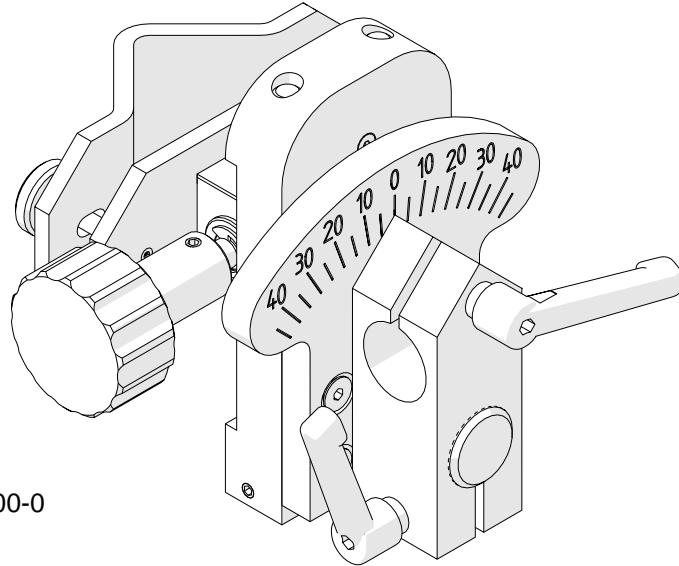

Part number:
UCW-0475-08-00-00-0

5.6.3. Machine torch holder (for oxy-fuel cutting)

Designed for torches with the handle diameter of 35 mm (1.38”) equipped with a rack. The holder allows adjustment of the vertical position of the torch by using the knob and rough adjustment of the angle.

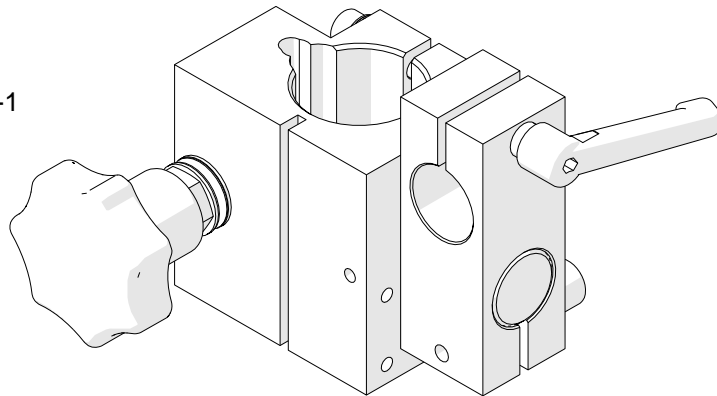

Part number:
UCW-0475-29-00-00-1

5.6.4. Precise machine torch holder (for oxy-fuel cutting)

Designed for torches with the handle diameter of 35 mm (1.38”) equipped with a rack. It allows adjustment of the vertical position of the torch by using the knob and precise adjustment of the angle.

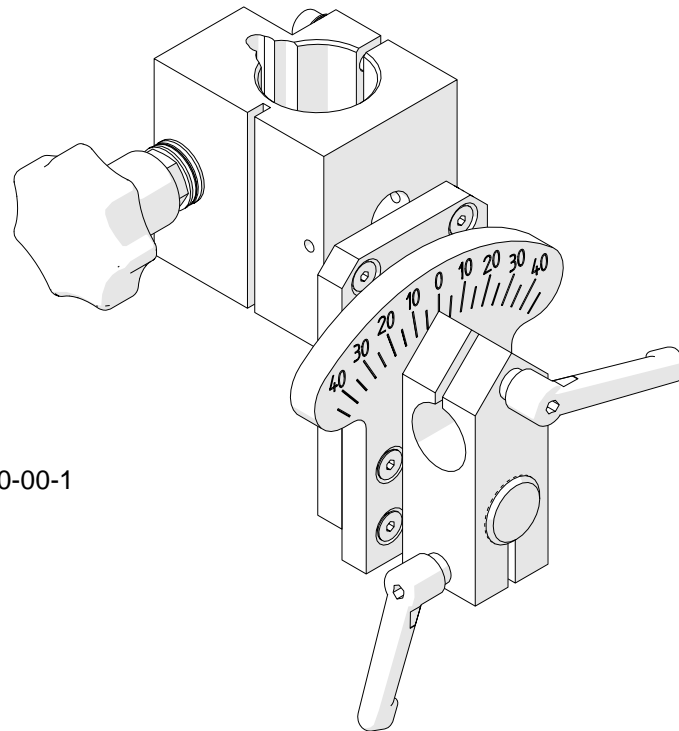

Part number:
UCW-0475-42-00-00-1

5.7. Slide rack holder

Designed to be combined with torch holders, which enables use of a second torch independently of the standard torch.

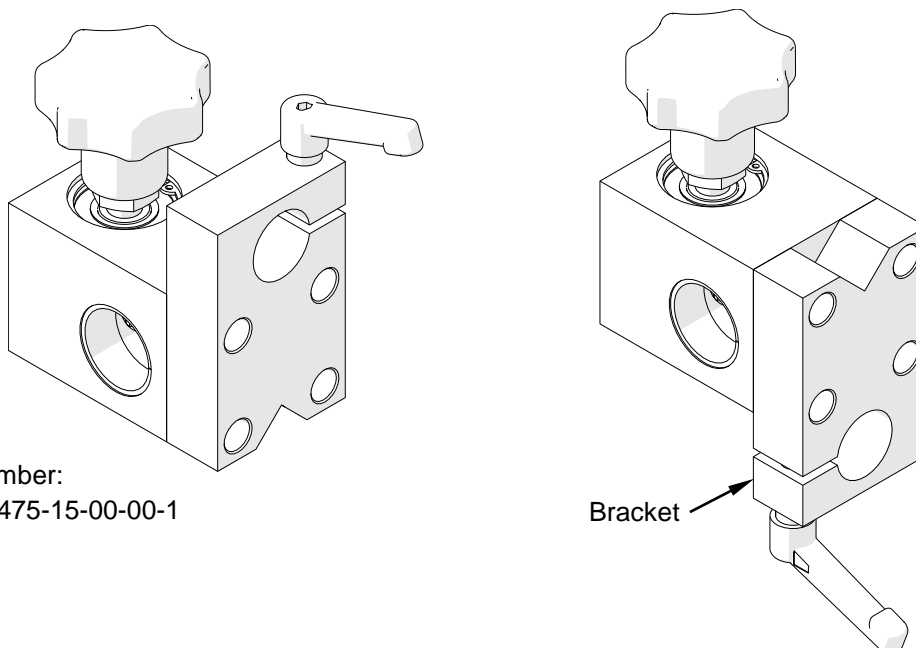

Part number:
UCW-0475-15-00-00-1

To adapt the rack holder for use with a precise torch holder, use the 4 mm hex wrench and unscrew four screws from the rack holder, rotate the bracket by 180°, and secure with the screws. Before linking to the rack holder, remove the clamping block (part with one or two handles) from the torch holder to be installed. Remove the counterweight or holder in use, and then place the combined holder onto the rack. Next, rotate the knob to set the combined holder in the required position along the rack.

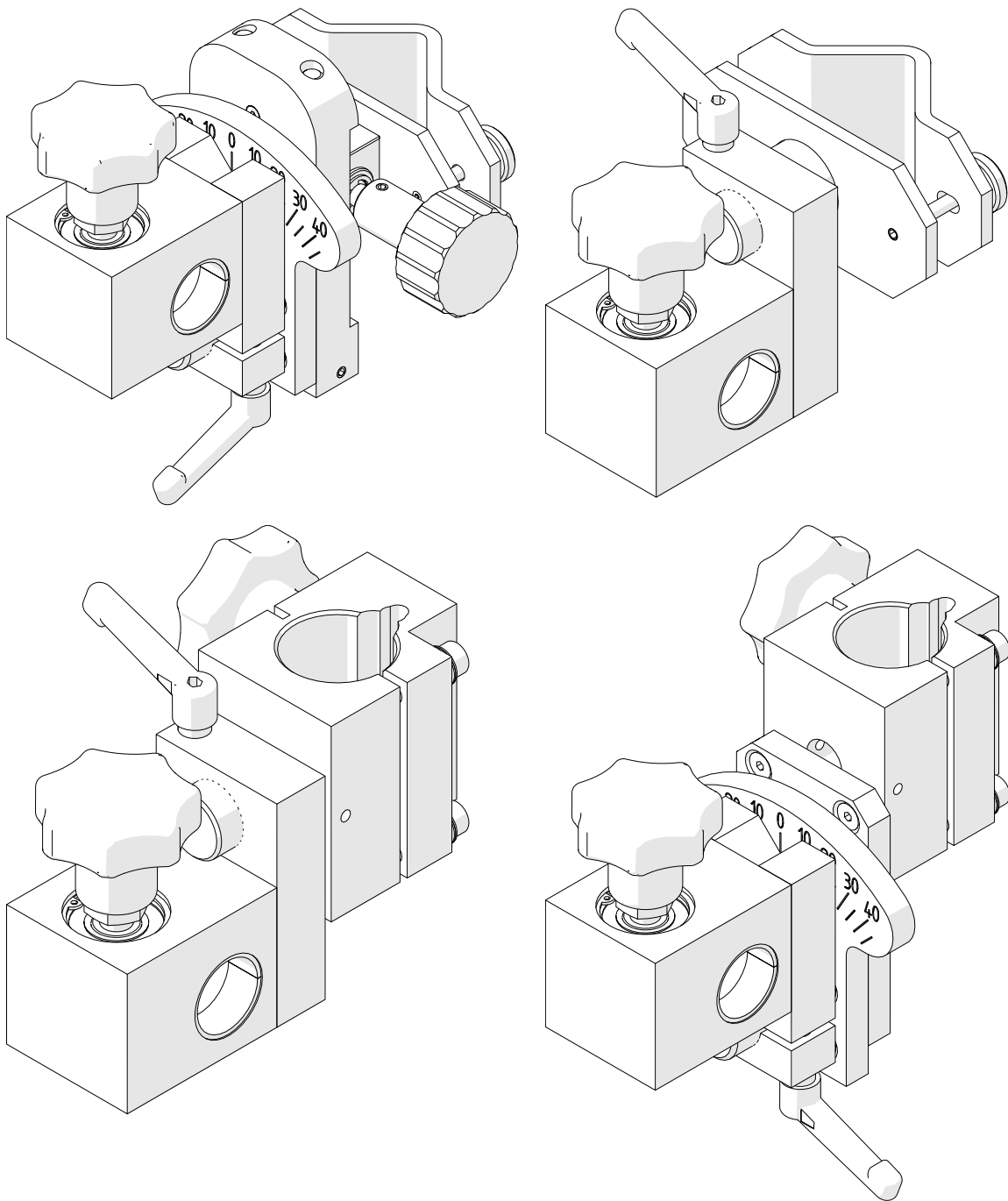

5.8. Circle cutting attachments

5.8.1. Circle cutting attachment for 240–1000 mm radius

Allows cutting holes with the radius of 240–1000 mm (0.8–3.3 ft; when used with the standard rack). To install, use the 3 mm hex wrench and unscrew two front screws from the bottom plate, and then use them to tighten the bracket to the exposed holes. Next, use the 4 mm hex wrench to fix the arm to the side wall with two M5x16 screws. Set the pilot pin above the center of the circle and turn on the magnet with the magnet lever.

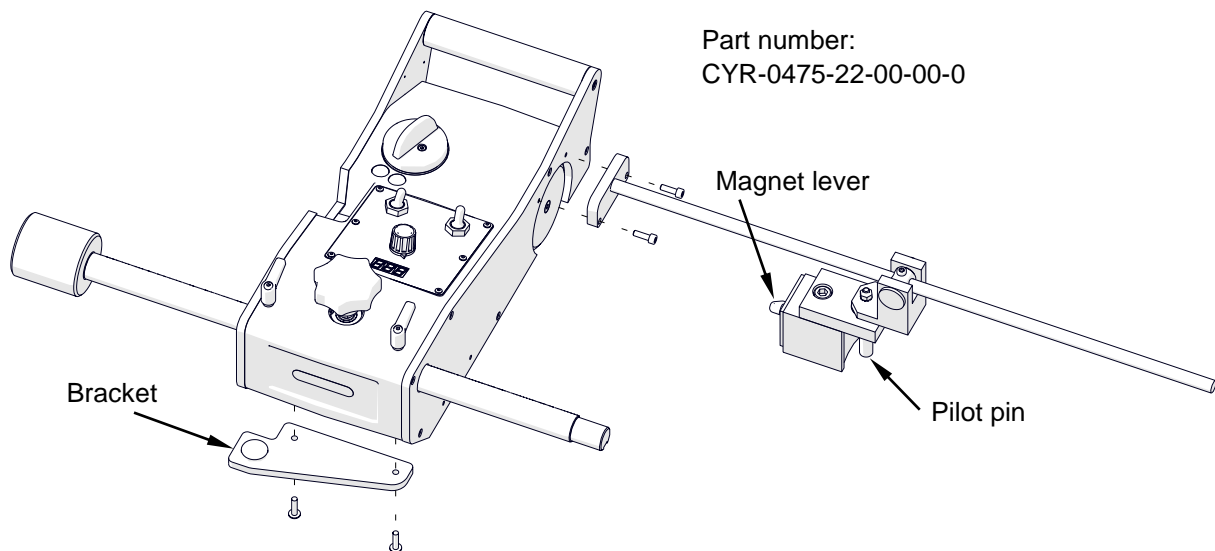

5.8.2. Circle cutting attachment for 400–2500 mm radius

Allows cutting holes with the radius of 400–2500 mm (1.3–8.2 ft; when used with the standard rack). To install, use the 3 mm hex wrench and unscrew two front screws from the bottom plate and use them to install the bracket. Next, use the 5 mm hex wrench to install the arm to the side wall with two M6x30 screws. Place the tip of the pilot pin in the center of the circle and lock the levers of the clamping blocks.

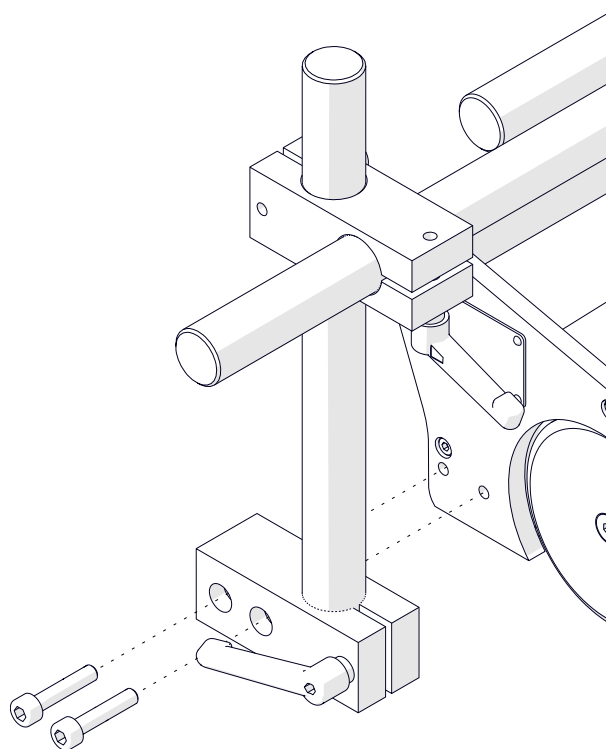
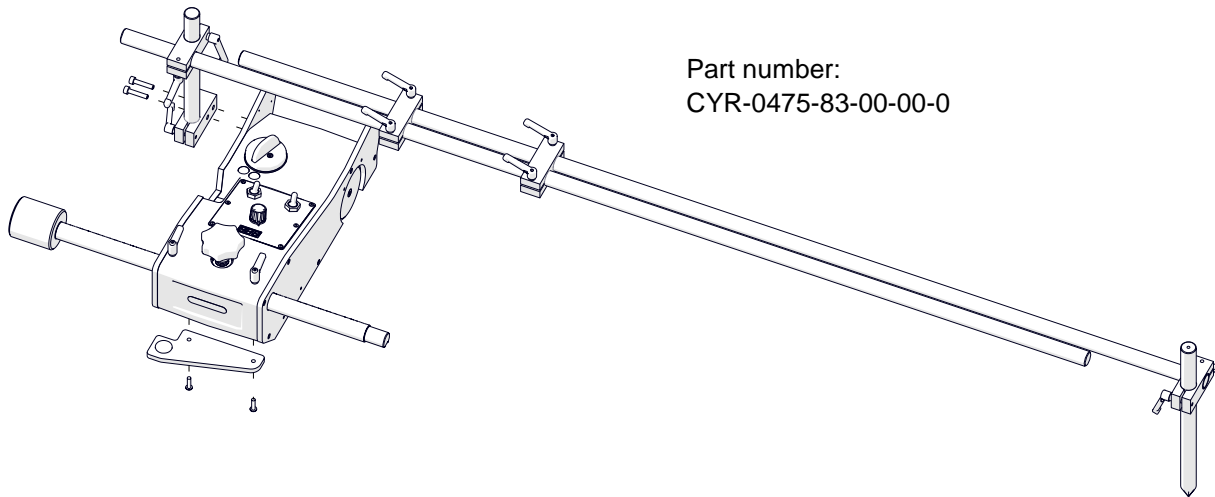

5.9. Left and right heat protection shield

Additionally protect the carriage from the influence of a high temperature. Install as shown in the figure below.

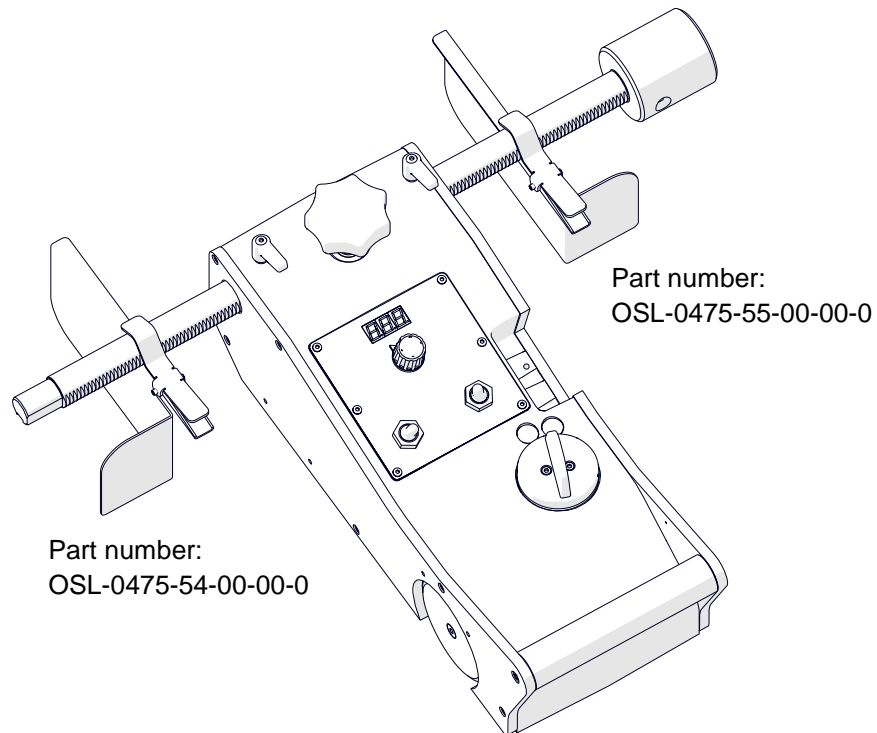

5.10. Bottom heat protection shield

Additionally protects the carriage from the influence of a high temperature. To install, loosen five screws with the 3 mm hex wrench, slide the shield under the heads of the screws according to the direction of the arrow, and then tighten the screws.

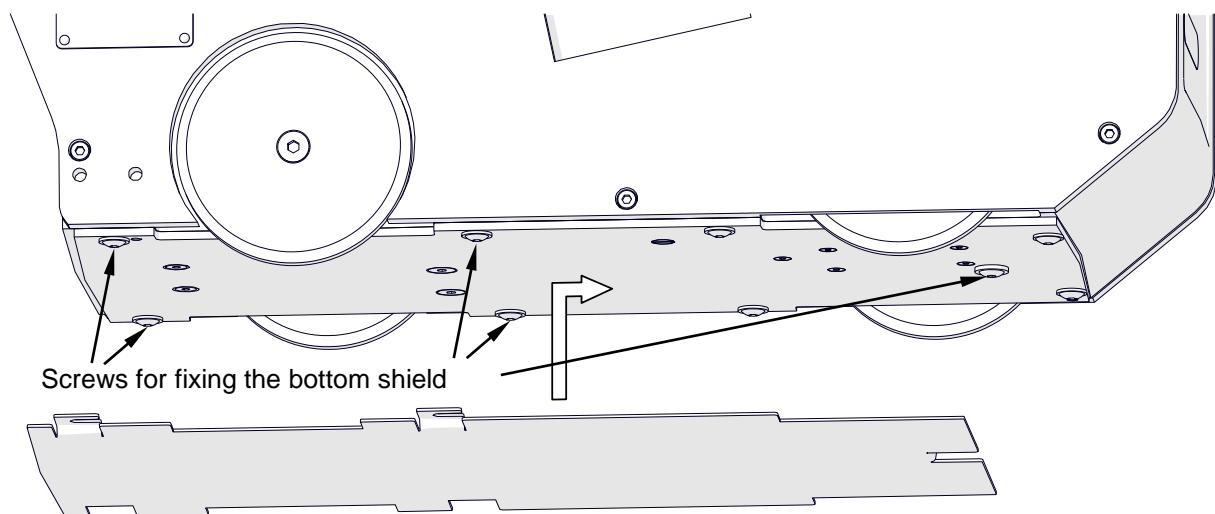

Part number: OSL-0475-53-00-00-0

5.11. Magnetic units

5.11.1. Magnetic unit

Allows clamping the track to ferromagnetic surfaces. The holding force on a 5 mm (0.2") thick surface is 1200 N up to a temperature of 100°C (212°F). At 180°C (356°F) the force decreases to 720 N.

Part number:
ZSP-0475-44-00-00-0

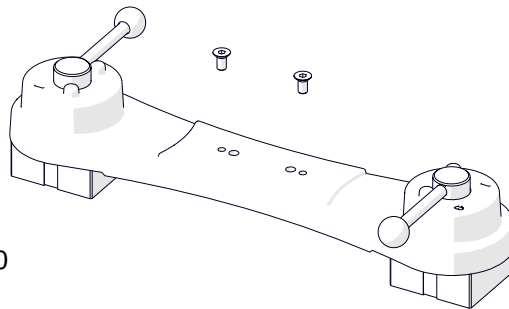

Tighten the unit to the track with the 4 mm hex wrench and two M6x12 screws. To clamp the unit to the surface, set the levers to 'I'.

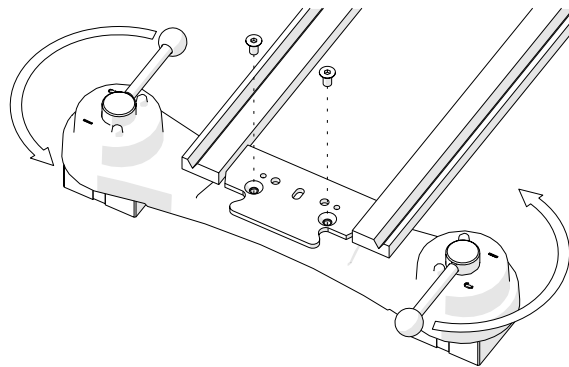

5.11.2. Narrow magnetic unit

Allows clamping the track to ferromagnetic surfaces. The holding force on a 5 mm (0.2") thick surface is 750 N up to a temperature of 100°C (212°F). At 180°C (356°F) the force decreases to 450 N.

Part number:
PDS-0582-10-00-02-0

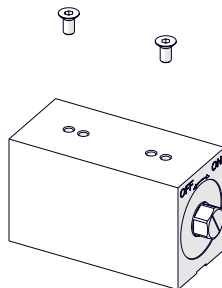

Install the unit in the same way as the magnetic unit is installed. To clamp the unit to the surface, use the 17 mm flat wrench (not included) and rotate the side screw to ON.

5.12. Vacuum track system

Dedicated to fixing the track to non-ferromagnetic surfaces.

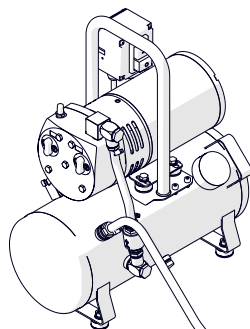

Part number (vacuum pump with safety reservoir):
AGR-0541-24-10-00-0 (115 V US)
AGR-0541-24-20-00-0 (230 V CEE)

Other parts of the system are described in a separate manual.

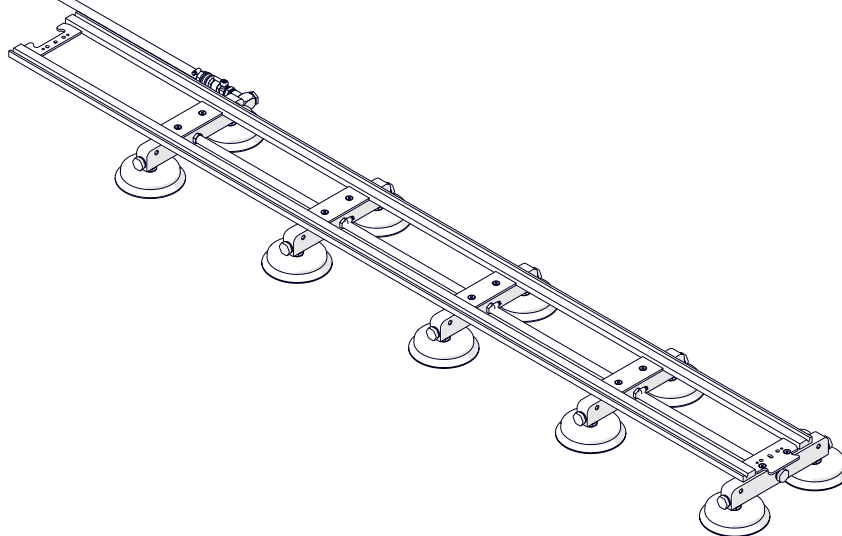

5.13. Gas manifold (for oxy-fuel cutting)

Provides safe gas delivery to 2- or 3-hose torches. Manifolds are available with or without gas cut-off valve in both metric and imperial versions.

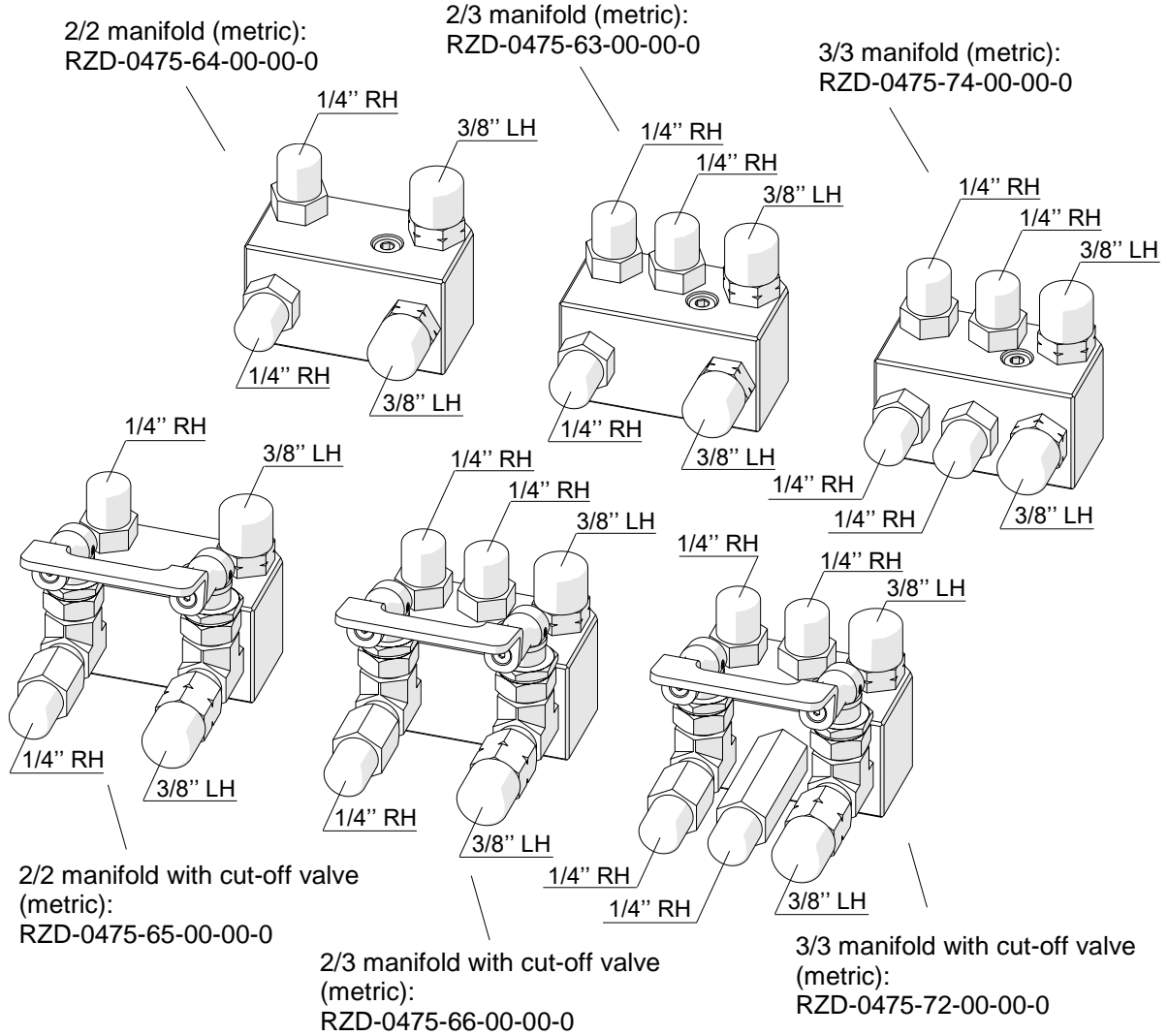

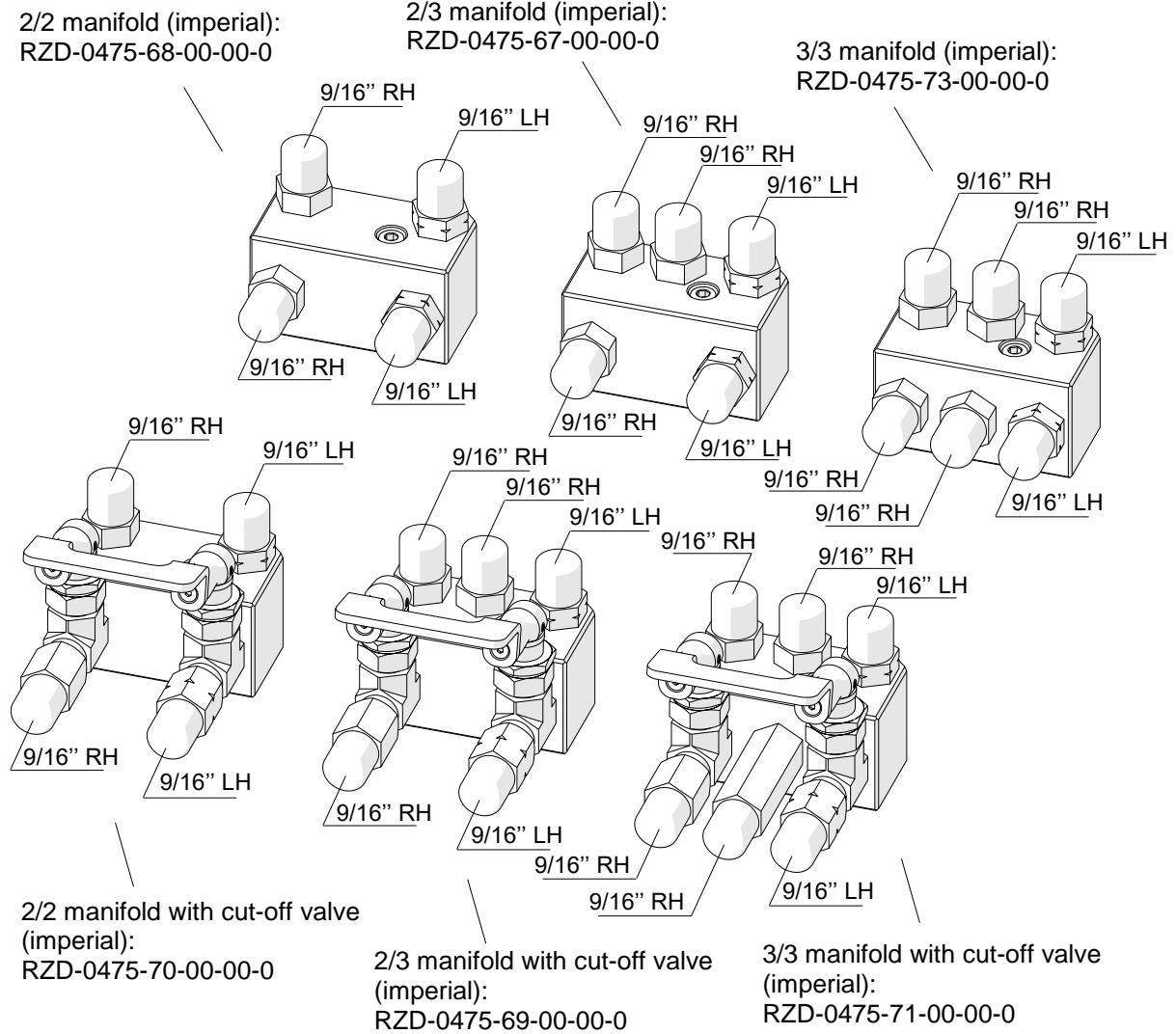

To install, place the manifold into the slot and tighten with the 4 mm hex wrench and the M5x45 screw.

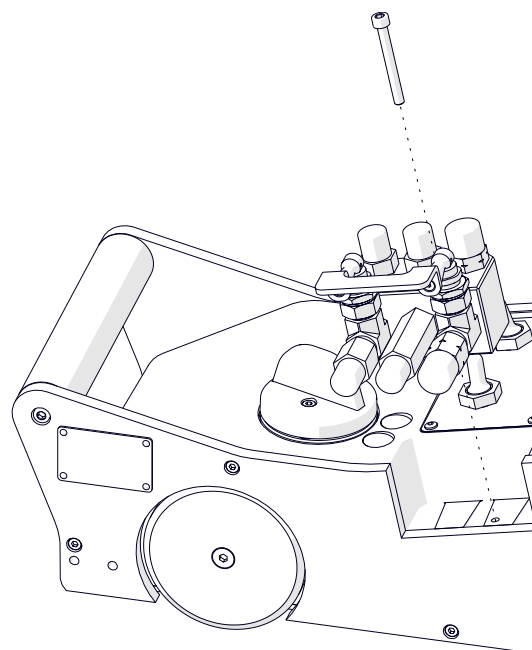

5.14. Gas manifold bracket (for oxy-fuel cutting)

Allows use of a second gas manifold. Use the 5 mm hex wrench and M6x8 screws to tighten the bracket to the side wall or, if used with the cable anchor, use the 5 mm hex wrench and M6x30 screws to tighten the bracket between the cable anchor and the side wall.

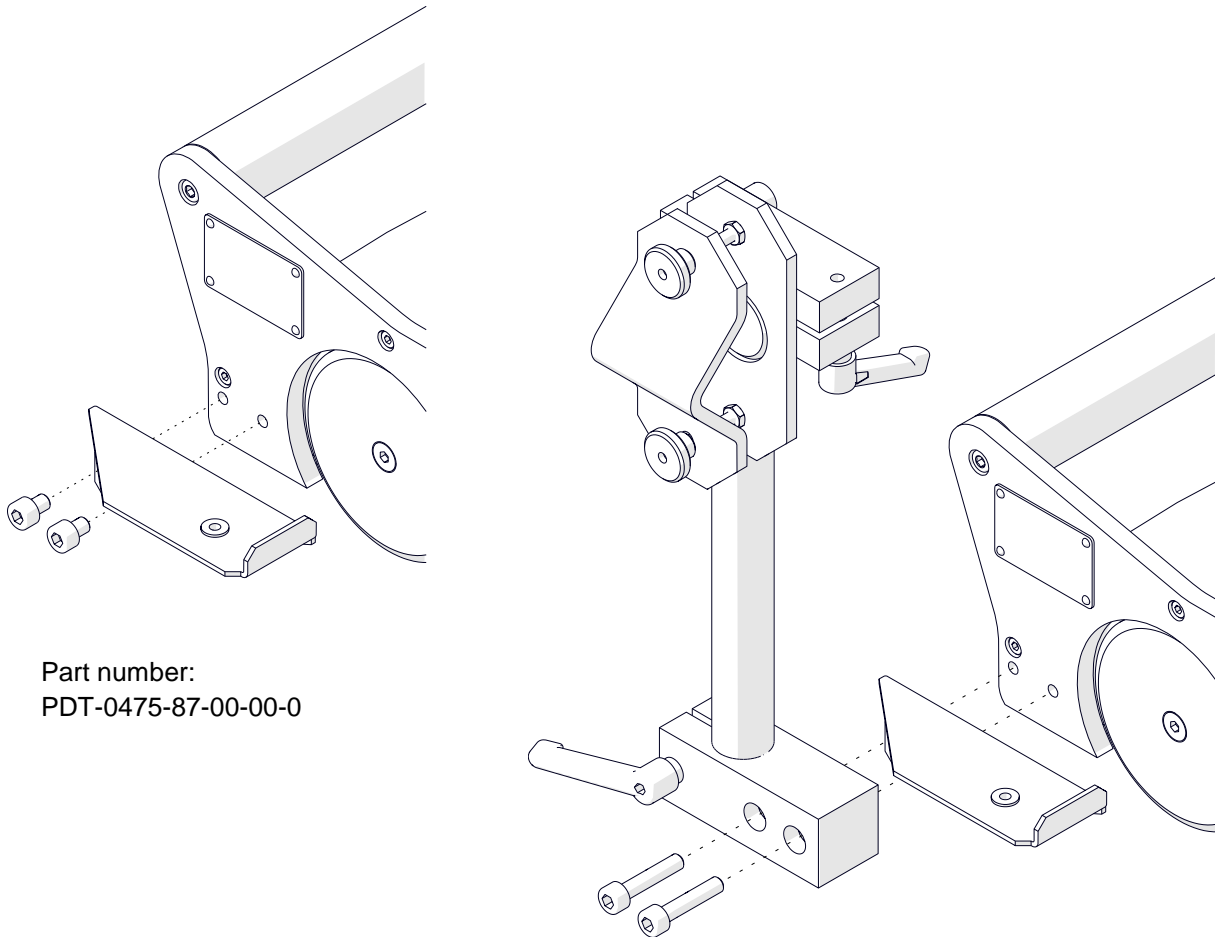

Part number:
PDT-0475-87-00-00-0

5.15. Arc ignition set (for plasma cutting)

Allows control of one torch by using the arc ignition cable.

Part number (arc ignition set):
ZSP-0475-58-00-00-0

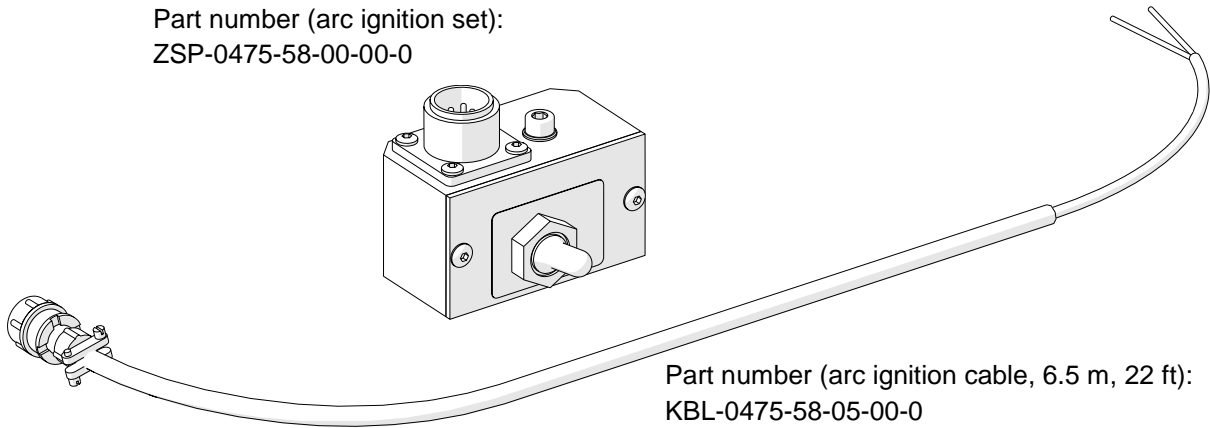

Part number (arc ignition cable, 6.5 m, 22 ft):
KBL-0475-58-05-00-0

To install, place the arc ignition set into the carriage slot, and then tighten the set with the 4 mm hex wrench and the M5x50 screw. Next, plug the cable into the socket and connect the brown wire to the first terminal of the cutting circuit, and connect the blue wire to the second terminal of the same circuit, according to the diagram shown in the figure.

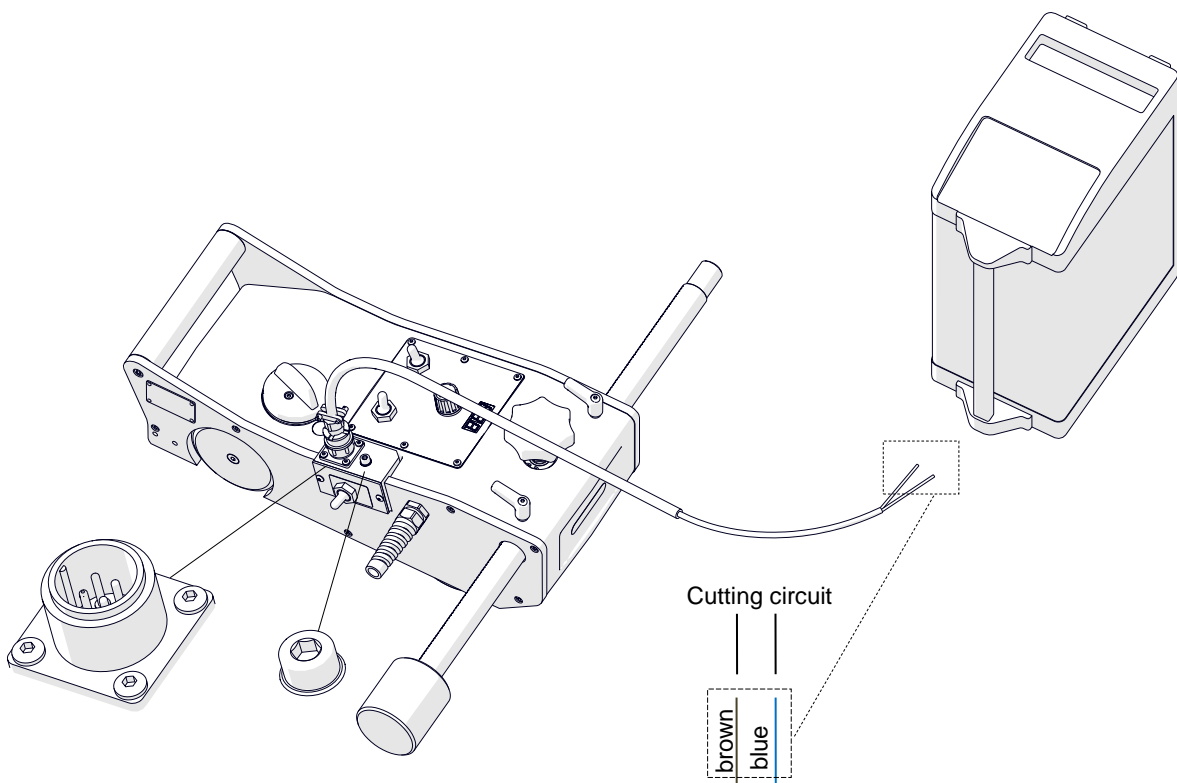

6. 115–230 V WIRING DIAGRAM

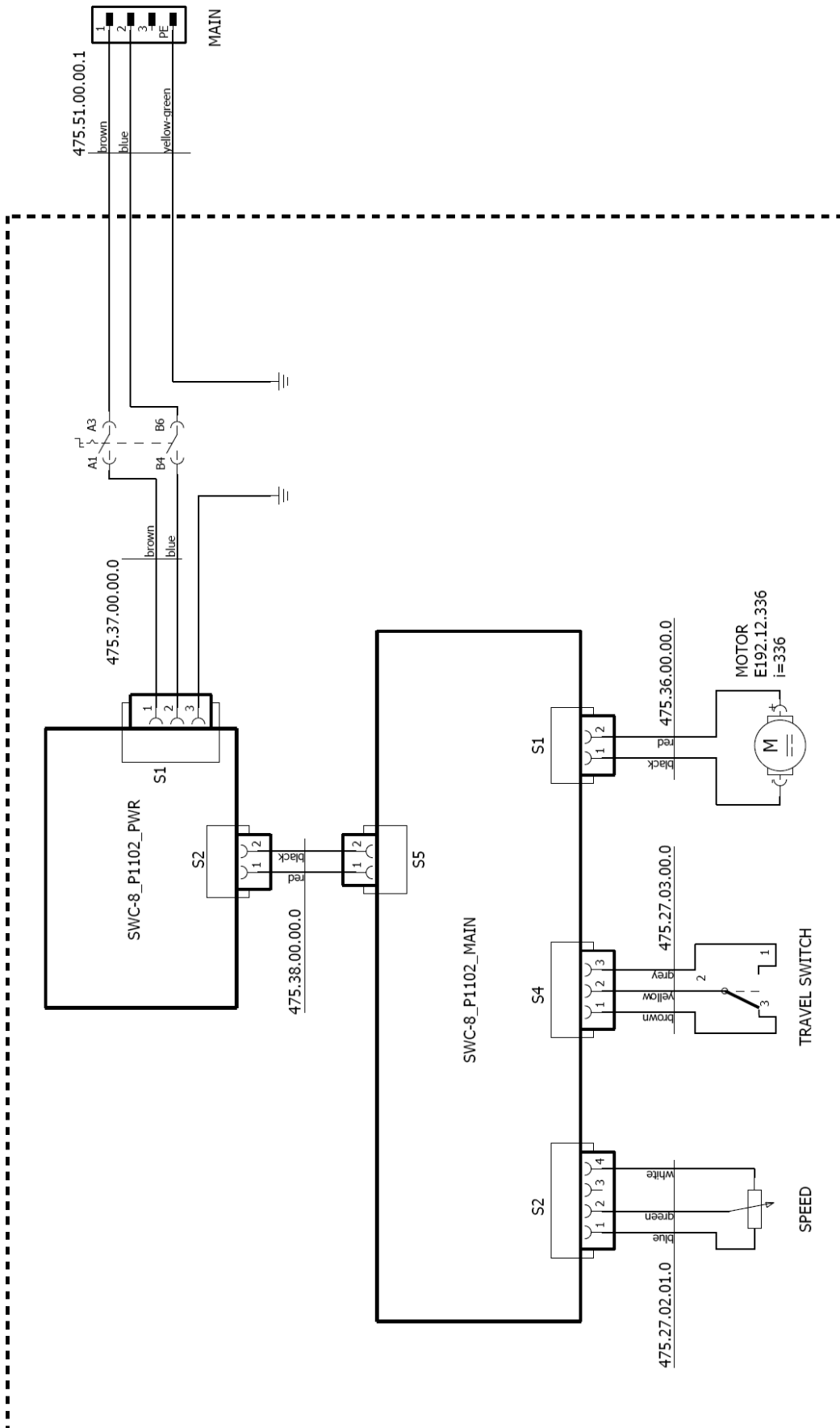

7. 115–230 V HS WIRING DIAGRAM

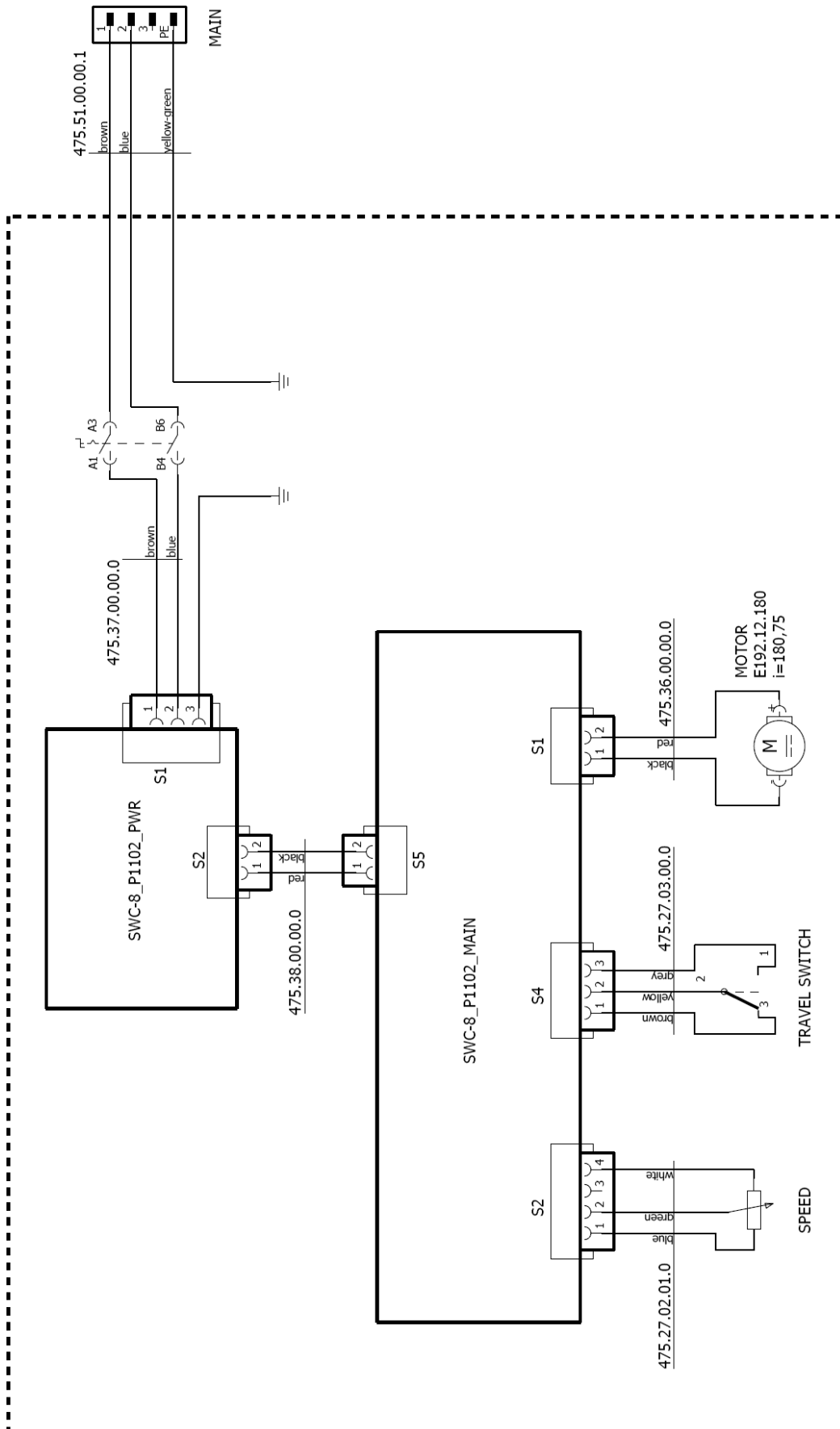

8. 115–230 V EXPLODED VIEWS AND PARTS LIST

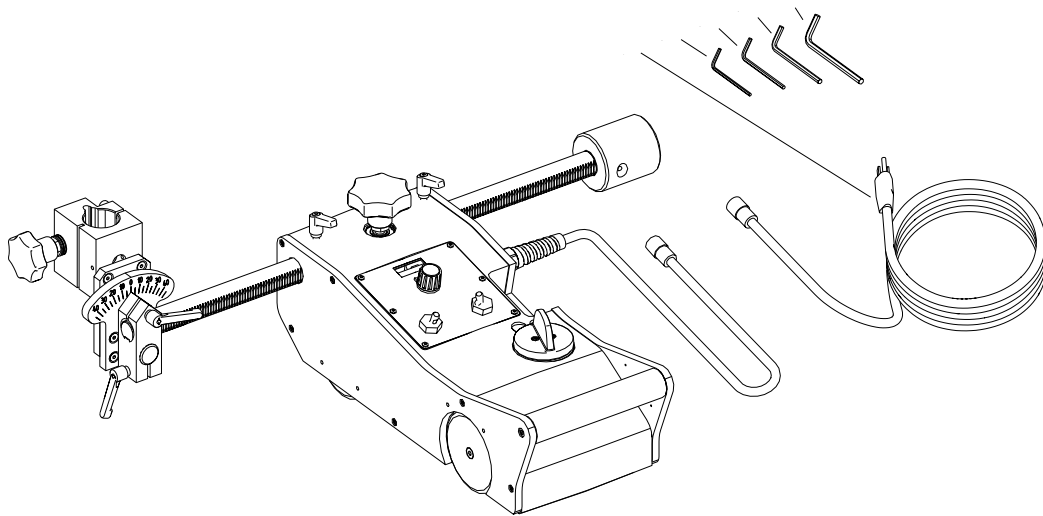

ITEM	PART NUMBER	DESCRIPTION	Q-TY
1	PWD-0466-18-00-00-0	POWER CORD 230V (CEE)	1
1	PWD-0466-21-00-00-0	POWER CORD 230V (AU)	1
1	PWD-0466-16-00-00-0	POWER CORD 120V (USA)	1
1	PWD-0466-23-00-00-0	POWER CORD 120V (UK type G)	1
1	PWD-0466-24-00-00-0	POWER CORD 3x1.5 – WITHOUT PLUG	1
2	KLC-000005	2.5 MM HEX WRENCH	1
3	KLC-000006	3 MM HEX WRENCH	1
4	KLC-000007	4 MM HEX WRENCH	1
5	KLC-000008	5 MM HEX WRENCH	1

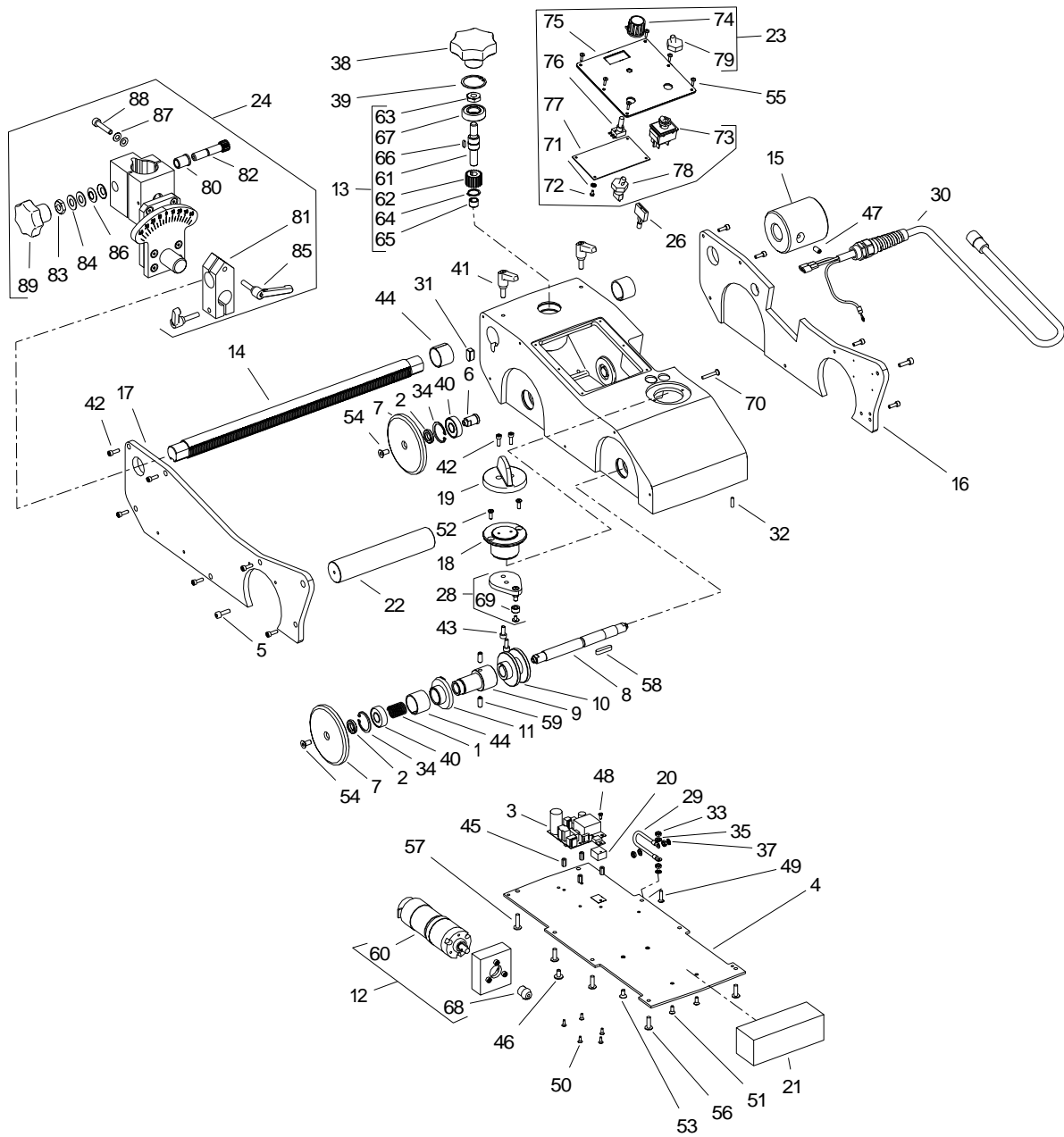

ITEM	PART NUMBER	DESCRIPTION	Q-TY
1	SPR-0256-00-07-00-0	CLUTCH SPRING	1
2	PDK-0256-00-13-00-0	DISTANCE WASHER	4
3	MDL-0466-02-03-00-1	POWER SUPPLY ELECTRONIC CONTROLLER ASSY	1
4	PKR-0475-01-00-00-2	BOTTOM COVER	1
5	SRB-000083	HEX SOCKET HEAD CAP SCREW M5x16	2
6	WLK-0475-03-01-00-0	BACK SHAFT	2
7	KOL-0475-03-02-00-1	DRIVE WHEEL II	4
8	WLK-0475-04-01-00-1	DRIVE SHAFT	1
9	ZBI-0475-04-02-00-0	DRIVING RING I	1
10	ZBI-0475-04-03-00-0	DRIVING RING II	1
11	KOL-0475-04-05-00-0	WHEEL	1
12	ZSP-0475-05-00-00-0	MOTOR ASSY	1
13	ZSP-0475-06-00-00-1	FEED ASSY	1
14	RAM-0525-07-00-00-0	RACK 540 MM (21")	1
15	PWG-0475-09-00-00-0	COUNTERWEIGHT 1.3 KG (2.9 LBS)	1
16	OSL-0475-11-00-00-1	COVER I	1
17	OSL-0475-12-00-00-1	COVER II	1
18	WLC-0475-16-00-00-0	CLUTCH KNOB	1
19	PNK-0475-16-03-00-2	CLUTCH	1
20	WSP-0475-17-00-00-0	POWER SUPPLY BRACKET	1
21	BLO-0475-18-00-00-0	BALLAST	1
22	RKJ-0475-19-00-00-0	CARRYING HANDLE	1
23	PNL-0475-27-00-00-0	CONTROL PANEL	1
24	UCW-0475-42-00-00-1	PRECISE MACHINE TORCH HOLDER	1
25*	WZK-0475-36-00-00-0	MOTOR WIRE SET	1
26	WZK-0475-37-00-00-0	POWER SWITCH WIRE SET	1
27*	WZK-0475-38-00-00-0	POWER SUPPLY-CONTROL PANEL WIRE SET	1
28	RAM-0475-47-00-00-0	SWITCH ARM ASSY	1
29	WZK-0475-50-00-00-0	GROUNDING WIRE SET	1
30	WZK-0475-51-00-00-1	POWER WIRE SET	1
31	WPS-0475-52-00-00-0	KEY 8x7x16	1
32	KLK-000034	DOWEL PIN 4n6x14	2
33	NKR-000013	HEX NUT M4	4
34	PRS-000018	INTERNAL RETAINING RING 28w	3
35	PDK-000015	ROUND WASHER 4.3	2
36	PDK-000140	SILICONE WASHER 18x13	1
37	PDK-000166	EXTERNAL TOOTH LOCK WASHER 4.3	2
38	PKT-000038	STAR KNOB D63	1
39	PRS-000022	INTERNAL RETAINING RING 32w	1
40	LOZ-000038	BALL BEARING 12x28x8	4
41	RKJ-000070	HANDLEVER M6-16	2
42	SRB-000062	HEX SOCKET HEAD CAP SCREW M4x12	14
43	SRB-000078	HEX SOCKET HEAD CAP SCREW M5x12	2
44	TLJ-000069	SELF LUBRICATING SLEEVE SBT 25x28x20	3
45	TLJ-000023	SLEEVE M3x10	4
46	WKR-000335	HEX SOCKET ROUND HEAD SCREW WITH FLANGE M5x10	1
47	WKR-000050	HEX SOCKET SET SCREW WITH FLAT POINT M6x12	1
48	WKR-000339	SELF-TAPPING SCREW M3x6	1
49	WKR-000166	COUNTERSUNK HEAD SCREW M4x16	1
50	WKR-000398	HEX SOCKET COUNTERSUNK HEAD SCREW M3x8	5

ITEM	PART NUMBER	DESCRIPTION	Q-TY
51	WKR-000130	HEX SOCKET COUNTERSUNK HEAD SCREW M4x10	2
52	WKR-000131	HEX SOCKET COUNTERSUNK HEAD SCREW M4x12	2
53	WKR-000133	HEX SOCKET COUNTERSUNK HEAD SCREW M5x10	2
54	WKR-000141	HEX SOCKET COUNTERSUNK HEAD SCREW M6x12	4
55	WKR-000287	HEX SOCKET BUTTON HEAD SCREW M3x10	6
56	WKR-000449	HEX SOCKET ROUND HEAD SCREW WITH FLANGE M5x16	6
57	WKR-000395	HEX SOCKET ROUND HEAD SCREW WITH FLANGE M5x20	2
58	WPS-000069	KEY A 5x5x25	1
59	ZTR-000004	BALL LOCK M6	2
60	MTR-0475-05-03-00-0	GEAR MOTOR ASSY	1
61	WLK-0475-06-02-00-1	GEAR SHAFT	1
62	KOL-0475-06-03-00-0	GEAR z=20 m=1	2
63	NKR-000087	NUT M10 SHORT	1
64	PRS-000005	EXTERNAL RETAINING RING 15z	1
65	TLJ-000095	SELF LUBRICATING SLEEVE 10/12x08	1
66	WPS-000005	KEY 3x3x10	1
67	LOZ-000101	BALL BEARING 15x32x8	1
68	ZBK-0475-05-02-00-0	COG	1
69	TLJ-0475-16-06-00-0	SLEEVE	1
70	WKR-000167	COUNTERSUNK HEAD SCREW M4x25	1
71	PDK-000058	EXTERNAL TOOTH LOCK WASHER 3.2	4
72	WKR-000181	CROSS RECESSED PAN HEAD SCREW M3x6	4
73	PNK-000026	LEVER SWITCH 641 H/3	1
74	PKT-000028	POTENTIOMETER KNOB	1
75	MSK-0475-27-01-00-0	PANEL PLATE ASSY	1
76	WZK-0475-27-02-01-0	POTENTIOMETER WIRE SET	1
77	MDL-0475-27-02-02-0	ELECTRONIC CONTROLLER	1
78	WZK-0475-27-03-00-0	TRAVEL DIRECTION WIRE SET	1
79	OSL-000036	LEVER SWITCH COVER	1
80	TLJ-0261-04-04-00-0	SLEEVE BEARING	1
81	KST-0475-08-03-00-0	BAR CLAMPING BLOCK	1
82	WLK-0475-29-04-00-0	GEAR SHAFT	1
83	NKR-000087	NUT M10 SHORT	1
84	PDK-000194	WASHER 10x22x1	2
85	RKJ-000043	HANDLEVER M6-25	2
86	SPR-000053	DISC SPRING 10.2x20x0.5	2
87	SPR-000010	DISC SPRING 6.2x12.5x0.6	4
88	SRB-000118	HEX SOCKET HEAD CAP SCREW M6x30	2
89	PKT-000039	KNOB D50xM10	1

* not shown in the drawing

9. 115–230 V HS EXPLODED VIEWS AND PARTS LIST

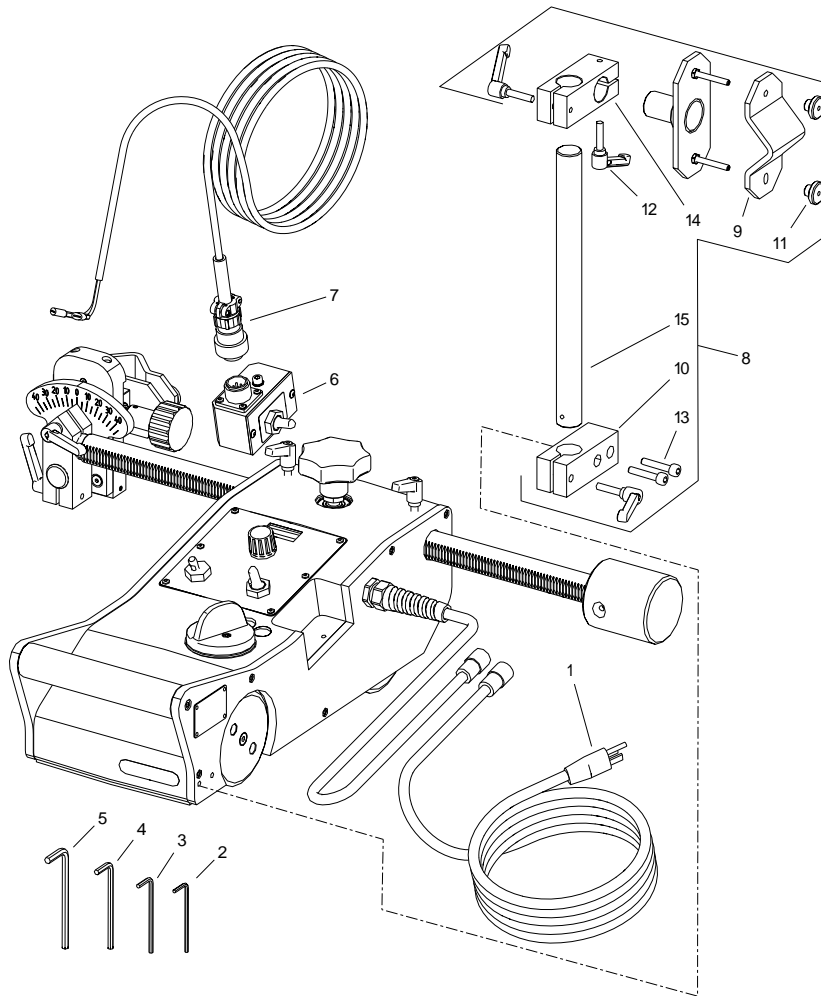

ITEM	PART NUMBER	DESCRIPTION	Q-TY
1	PWD-0466-18-00-00-0	POWER CORD 230V (CEE)	1
1	PWD-0466-21-00-00-0	POWER CORD 230V (AU)	1
1	PWD-0466-16-00-00-0	POWER CORD 120V (USA)	1
1	PWD-0466-23-00-00-0	POWER CORD 120V (UK type G)	1
1	PWD-0466-24-00-00-0	POWER CORD 3x1.5 – WITHOUT PLUG	1
2	KLC-000005	2.5 MM HEX WRENCH	1
3	KLC-000006	3 MM HEX WRENCH	1
4	KLC-000007	4 MM HEX WRENCH	1
5	KLC-000008	5 MM HEX WRENCH	1
6	ZSP-0475-58-00-00-0	ARC IGNITION SET	1
7	KBL-0475-58-05-00-0	START-STOP ARC IGNITION CABLE 6.5 M (20 FT)	1
8	PDT-0475-34-00-00-0	CABLE ANCHOR	1
9	DCS-0475-25-00-00-0	TORCH CLAMP	1
10	KST-0475-34-02-00-0	CLAMPING BLOCK	1
11	NKR-000077	KNURLED NUT M5	2
12	RKJ-000043	HANDLEVER M6-25	3
13	SRB-000118	HEX SOCKET HEAD CAP SCREW M6x30	2
14	KST-0466-43-04-00-0	DOUBLE CLAMPING BLOCK	1
15	WLK-0475-26-03-00-0	BAR	1

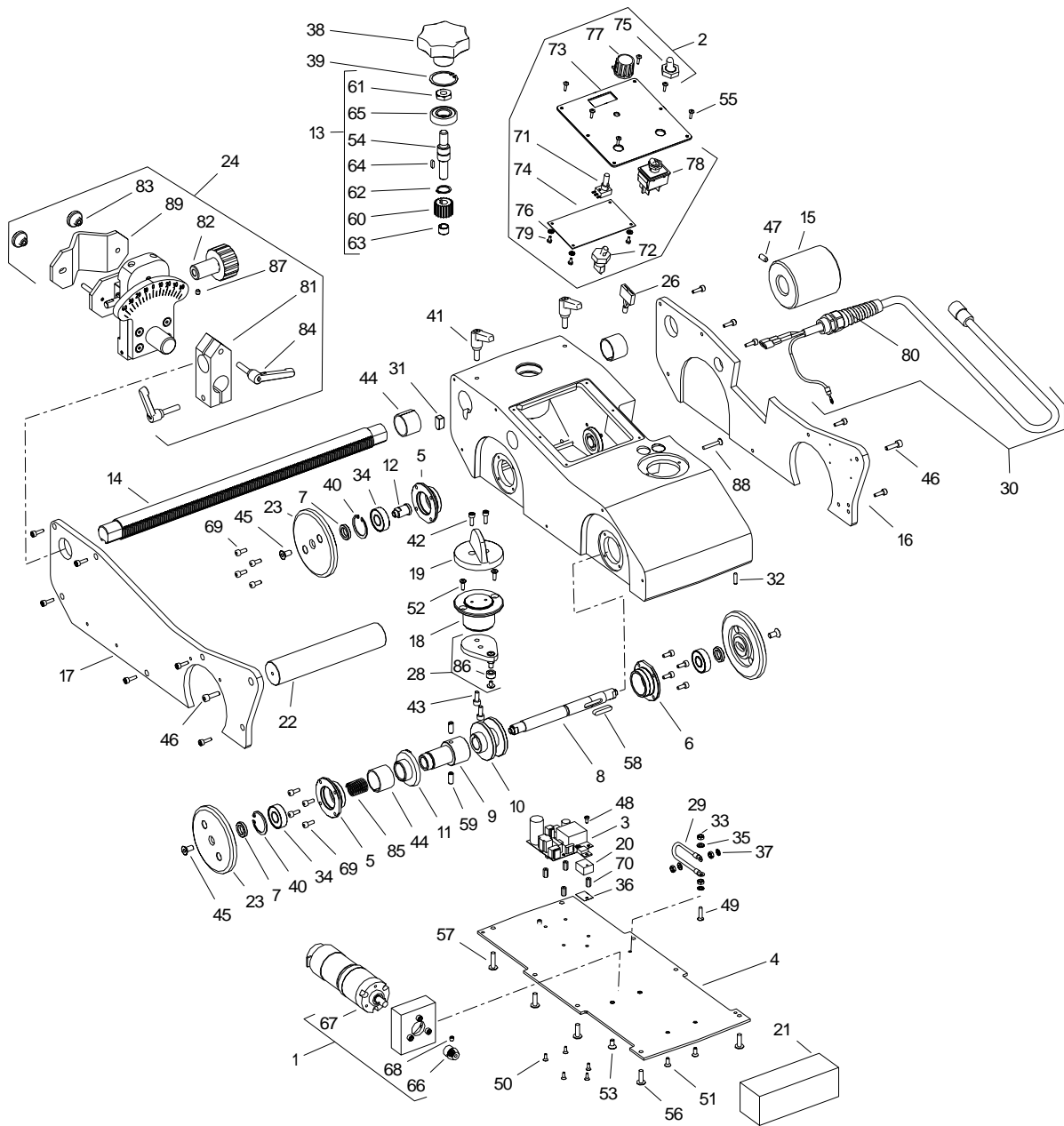

ITEM	PART NUMBER	DESCRIPTION	Q-TY
1	ZSP-0527-01-01-00-0	MOTOR ASSY	1
2	PNL-0527-02-00-00-0	CONTROL PANEL	1
3	MDL-0466-02-03-00-1	POWER SUPPLY ELECTRONIC CONTROLLER ASSY	1
4	PKR-0475-01-00-00-2	BOTTOM COVER	1
5	TLJ-0256-00-02-00-0	RESISTING SHAFT SLEEVE	3
6	TLJ-0256-00-03-00-0	OPEN SHAFT SLEEVE	1
7	PDK-0256-00-13-00-0	DISTANCE WASHER	4
8	WLK-0475-04-01-00-1	DRIVE SHAFT	1
9	ZBI-0475-04-02-00-0	DRIVING RING I	1
10	ZBI-0475-04-03-00-0	DRIVING RING II	1
11	KOL-0475-04-05-00-0	WHEEL	1
12	WLK-0475-03-01-00-0	BACK SHAFT	2
13	ZSP-0475-06-00-00-1	FEED ASSY	1
14	RAM-0525-07-00-00-0	ARM I	1
15	PWG-0475-09-00-00-0	COUNTERWEIGHT 1.3 KG (2.9 LBS)	1
16	OSL-0475-11-00-00-1	COVER I	1
17	OSL-0475-12-00-00-1	COVER II	1
18	WLC-0475-16-00-00-0	CLUTCH KNOB	1
19	PNK-0475-16-03-00-2	CLUTCH	1
20	WSP-0475-17-00-00-0	POWER SUPPLY BRACKET	1
21	BLO-0475-18-00-00-0	BALLAST	1
22	RKJ-0475-19-00-00-0	CARRYING HANDLE	1
23	KOL-0475-03-02-00-0	DRIVE WHEEL II	4
24	UCW-0475-08-00-00-0	PRECISE HOLDER	1
25*	WZK-0475-36-00-00-0	MOTOR WIRE SET	1
26	WZK-0475-37-00-00-0	POWER SWITCH WIRE SET	1
27*	WZK-0475-38-00-00-0	POWER SUPPLY-CONTROL PANEL WIRE SET	1
28	RAM-0475-47-00-00-0	SWITCH ARM ASSY	1
29	WZK-0475-50-00-00-0	GROUNDING WIRE SET	1
30	WZK-0475-51-00-00-1	POWER WIRE SET	1
31	WPS-0475-52-00-00-0	KEY 8x7x16	1
32	KLK-000034	DOWEL PIN 4n6x14	2
33	NKR-000013	HEX NUT M4	4
34	LOZ-000038	BALL BEARING 12x28x8	4
35	PDK-000015	ROUND WASHER 4.3	2
36	PDK-000140	SILICONE WASHER 18x13	1
37	PDK-000166	EXTERNAL TOOTH LOCK WASHER 4.3	2
38	PKT-000038	STAR KNOB D63	1
39	PRS-000022	INTERNAL RETAINING RING 32w	1
40	PRS-000018	INTERNAL RETAINING RING 28w	3
41	RKJ-000070	HANDLEVER M6-16	2
42	SRB-000062	HEX SOCKET HEAD CAP SCREW M4x12	14
43	SRB-000078	HEX SOCKET HEAD CAP SCREW M5x12	2
44	TLJ-000069	SELF LUBRICATING SLEEVE SBT 25x28x20	3
45	WKR-000141	HEX SOCKET COUNTERSUNK HEAD SCREW M6x12	4
46	SRB-000083	HEX SOCKET HEAD CAP SCREW M5x16	2
47	WKR-000050	HEX SOCKET SET SCREW WITH FLAT POINT M6x12	1
48	WKR-000339	SELF-TAPPING SCREW M3x6	1
49	WKR-000166	COUNTERSUNK HEAD SCREW M4x16	1
50	WKR-000398	HEX SOCKET COUNTERSUNK HEAD SCREW M3x8	5

ITEM	PART NUMBER	DESCRIPTION	Q-TY
51	WKR-000130	HEX SOCKET COUNTERSUNK HEAD SCREW M4x10	2
52	WKR-000131	HEX SOCKET COUNTERSUNK HEAD SCREW M4x12	2
53	WKR-000133	HEX SOCKET COUNTERSUNK HEAD SCREW M5x10	3
54	WLK-0475-06-02-00-1	GEAR SHAFT	1
55	WKR-000287	HEX SOCKET BUTTON HEAD SCREW M3x10	6
56	WKR-000449	HEX SOCKET ROUND HEAD SCREW WITH FLANGE M5x16	6
57	WKR-000395	HEX SOCKET ROUND HEAD SCREW WITH FLANGE M5x20	2
58	WPS-000069	KEY A 5x5x25	1
59	ZTR-000004	BALL LOCK M6	2
60	KOL-0475-06-03-00-0	GEAR z=20 m=1	1
61	NKR-000087	NUT M10 SHORT	1
62	PRS-000005	EXTERNAL RETAINING RING 15z	1
63	TLJ-000095	SELF LUBRICATING SLEEVE 10x12x08	1
64	WPS-000005	KEY 3x3x10	1
65	LOZ-000101	BALL BEARING 15x32x8	1
66	ZBK-0475-05-02-00-0	COG	1
67	MTR-0527-01-01-01-0	GEAR MOTOR ASSY	1
68	WKR-000047	HEX SOCKET SET SCREW WITH FLAT POINT M5x5	1
69	SRB-000061	HEX SOCKET HEAD CAP SCREW M4x10	16
70	TLJ-000023	SLEEVE M3x10	4
71	WZK-0475-27-02-01-0	POTENTIOMETER WIRE SET	1
72	WZK-0475-27-03-00-0	TRAVEL DIRECTION WIRE SET	1
73	MSK-0527-02-01-00-0	PANEL PLATE ASSY	1
74	MDL-0527-02-02-00-0	ELECTRONIC CONTROLLER	1
75	OSL-000036	LEVER SWITCH COVER	1
76	PDK-000058	EXTERNAL TOOTH LOCK WASHER 3.2	4
77	PKT-000028	POTENTIOMETER KNOB	1
78	PNK-000026	LEVER SWITCH 641 H/3	1
79	WKR-000181	CROSS RECESSED PAN HEAD SCREW M3x6	4
80	DLW-000007	CABLE GLAND WITH STRAIN RELIEF PG11	1
81	KST-0475-08-03-00-0	BAR CLAMPING BLOCK	1
82	PKT-0475-08-04-00-0	KNOB	1
83	NKR-000077	KNURLED NUT M5	2
84	RKJ-000043	HANDLEVER M6-25	2
85	SPR-0256-00-07-00-0	CLUTCH SPRING	1
86	TLJ-0475-16-06-00-0	SLEEVE	1
87	WKR-000047	HEX SOCKET SET SCREW WITH FLAT POINT M5x5	1
88	WKR-000167	COUNTERSUNK HEAD SCREW M4x25	1
89	DCS-0475-25-00-00-0	TORCH CLAMP	1

* not shown in the drawing

10. DECLARATION OF CONFORMITY

EC Declaration of Conformity

We

***PROMOTECH sp. z o.o.
ul. Elewatorska 23/1
15-620 Białystok
Poland***

declare with full responsibility that:

TORCH RUNNER (HS) CUTTING CARRIAGE

is manufactured in accordance with the following standards:

- EN 50144-1
- EN 60974-10

and satisfies safety regulations of the guidelines: 2004/108/EC, 2006/95/EC, 2006/42/EC.

Person authorized to compile the technical file:

Marek Siergiej, ul. Elewatorska 23/1, 15-620 Białystok



Białystok, 23 February 2012

Marek Siergiej
CEO

11. QUALITY CERTIFICATE

Machine control card

TORCH RUNNER (HS) CUTTING CARRIAGE

- 115–230 V**
- 115–230 V HS**

Serial number

Electric test

Type of test	Result	Name of tester
Insulation electrical strength test (1000 V, 50 Hz)	 Date
Continuity test of the protective earth system Ω Signature

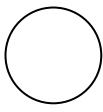
Quality control 

Adjustments, inspections

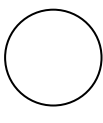
Quality control 

12. WARRANTY CARD

WARRANTY CARD No.....

..... in the name of Manufacturer warrants the Torch Runner (HS) Cutting Carriage to be free of defects in material and workmanship under normal use for a period of 12 months from the date of sale.

This warranty does not cover damage or wear that arise from misuse, accident, tempering or any other causes not related to defects in workmanship or material.

Date of production

Serial number

Date of sale

Signature of seller.....

1.09 / 1 March 2017

WE RESERVE THE RIGHT TO MAKE CHANGES IN THIS MANUAL WITHOUT NOTICE