

**SAFETY INSTRUCTIONS
AND OPERATOR'S MANUAL
FOR
DRILLING MACHINE
D4X**



6200 S Troy Circle, Suite 110
Centennial, CO. 80111

1-87steelmax.com www.steelmax.com sales@steelmax.com

TABLE OF CONTENTS

I.	SAFETY INSTRUCTION	3
1.	General information	3
2.	Important safety instruction.....	3
II.	OPERATING INSTRUCTIONS.....	6
1.	Cutters and optional equipment features.....	6
2.	Magnetic drilling machine start up	9
III.	MAINTENANCE AND SERVICE	17
IV.	TECHNICAL DATA	19
V.	PARTS LIST/EXPLODED VIEW.....	22
VI.	ELECTRICAL DIAGRAM.....	35
VII.	EC DECLARATION OF CONFORMITY	37
VII.	MACHINE TEST CERTIFICATE	38
VIII.	WARRANTY CARD	39
IX.	ANNULAR CUTTERS.....	40



**BEFORE YOU START WORK WITH THE MACHINE,
PLEASE READ THESE INSTRUCTIONS CAREFULLY
AND USE ALL RECOMMENDATIONS.**

I. SAFETY INSTRUCTION

Drilling machine on electromagnetic base should be used only for the purpose described in this manual. Using the machine incorrectly or not for its intended use may result in serious injury and/or death.

1. GENERAL INFORMATION

Portable drilling machines with electromagnetic bases are fast becoming very universal power tools not only at steel fabricating workshops or steel building sites but also at every factory maintenance workshop, truck manufacture & repair company, military equipment service, onboard ship maintenance shop etc.

But full advantages of electromagnetic drilling machines can be achieved only with optimal tooling. Milling cutters are designed and manufactured specifically for use with these machines and offer a whole range of advantages in one pass and with precision not otherwise attainable without heavy stationary equipment. The drill is equipped with a powerful motor and automatically adjustable slides.

2. GENERAL SAFETY ADVICE

Drilling machine must not be used when:

1. The operator has not read the Operator's Manual.
2. The work to be done is not in agreement with the recommendations in this Manual.
3. Drilling machine is not complete or has been repaired with non-original parts.
4. Power supply parameters do not conform to those stated on the motor's plate.
5. Machines operator has not checked the condition of the drilling machine, condition of power cable, control panel or cutter.
6. Power supply connection is not equipped with a protection circuit (fuse or circuit breaker).
7. Machine is not secured with safety chain as a protection from dropping especially when used at heights or in vertical or upside-down positions.
8. Bystanders are present in the immediate vicinity of machine.

Important rules of safe use of drilling machine

- 1) Before attempting to work with the machine check condition of power cord and plug.
- 2) The drilling machine should be connected to an installation equipped with protection circuit (neutral or ground) and protected with a 16 A fuse for 220V and 32 A fuse for

120V. **When used on building sites, it must be supplied through a separation transformer made in the second class of protection.**

- 3) Machine can be used outdoors, but is not weatherproof. Do not expose to rain, snow or frost.
- 4) Machine should not be used on: rusty surfaces, steel plates with thick covering of paint, uneven surfaces, next to a welding machine or left on steel that will be welded.
- 5) In all cases always use a safety chain/strap (see drawing 1). The safety chain should not be loose! To avoid this situation the safety chain should be wrapped around the element it is drilling. Loss of electric power will cause a loss of electromagnetic adherence to the metal and will cause the drill to fall which could cause serious injury or death.
- 6) Do not use the machine in explosion hazard zones.
- 7) Do not start work if the machine has excessive play on guide slides.
- 8) Always wear safety goggles and ear protection.
- 9) Do not remove metal chips with bare hands.

Drawing 1.

Examples how safety chain should be fastened.



Safety chain can also secure the drill through the handle.

- 10) Do not touch the spindle and cutter during work.
- 11) Tools must be fastened firmly. When a milling cutter is used, check before the start of work to assure that tool retaining screws are screwed tight.
- 12) The use of blunt or damaged tools can be hazardous.
- 13) Do not use milling cutter without pilots, and arbors without ejection spring.



Do not touch or replace the tool with power source on – while electromagnetic base is being used.

- 14) Use tools recommended in Operator's Manual only.
- 15) After use, always clean metal chips (with gloves or tool) and coolant from the drilling machine.
- 16) Always unplug the machine from the power supply during any work on the machine.
- 17) In the case that the machine falls on a hard surface, from a height, is wet or is subjected to other unfortunate events that could affect its operation, work should be terminated immediately and the machine should be sent to service for inspection as soon as possible.

It is not advised to use drill on steel thinner than (less than 3/8" (10 mm)). On thin steel (less than 3/8" (10 mm)) the magnet's adhesive power would be significantly reduced which can cause the machines failure to adhere to the metal and individuals injury. The machine should be located on the work piece with the entire surface of the electromagnetic base contacting the metal!
It is recommended that each time, before positioning the machine the metal surface under the electromagnetic base should be sanded down with abrasive paper!



Please follow all recommendations.

II. START UP AND OPERATION

1. Cutters and optional equipment features

This drilling machine's spindle has a socket with a Morse taper which makes it possible to use twist drills or milling cutters by using an AMT Arbor for fixing them in the socket spindle taper [Drawing 2].

Milling cutter (2) is located inside the arbor body (1) and is fastened with screws (3). While fastening the cutter in the socket, be aware that screws should be screwed tight so that they could not come loose. It is important to position the cutter in relation to the socket in such a way that the flats on the cutter shank are positioned opposite to the fixing screws (3). Both fastening screws (3) must be used to fasten the cutter. Pilot (5) is located inside the cutter. It makes it easier to position milling cutter over center of a planned hole. During drilling as the cutter goes deep into steel, the pilot moves back into the arbor body and tightens the discharge spring (4). That spring ejects the slug which is a by-product of milling a hole with a center free cutter.

Basically milling cutters are designed to make through holes. On occasions when there is a need for an overlapping hole the pilot should not be used. [Drawing 3]

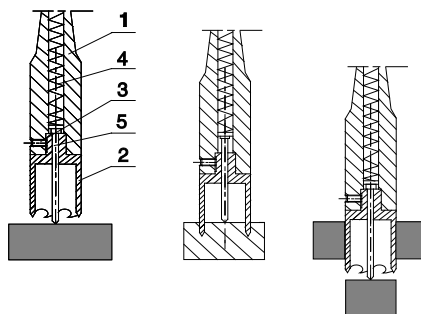

Drawing 2. Principle of milling cutter's work

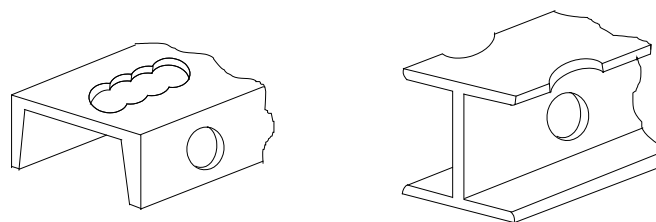

Drawing 3. A few types of holes that can be done with a milling cutter.

1.1 Installing and uninstalling the arbor



The arbor installation and uninstallation should be carried out when the machine is turned off and disconnected from the power grid!

Installing the arbor:

- a) Raise the guard (2) to the maximum,
- b) Clean the inside of the spindle using a cotton cloth,
- c) Before mounting, clean off the lubricant from the new arbor (3),
- d) Place the arbor with the fin on top, and place it in the spindle,
- e) By turning the arbor, align the fin to the appropriate slot in the spindle,
- f) Using a light impact from the bottom side, drive the arbor into the spindle.

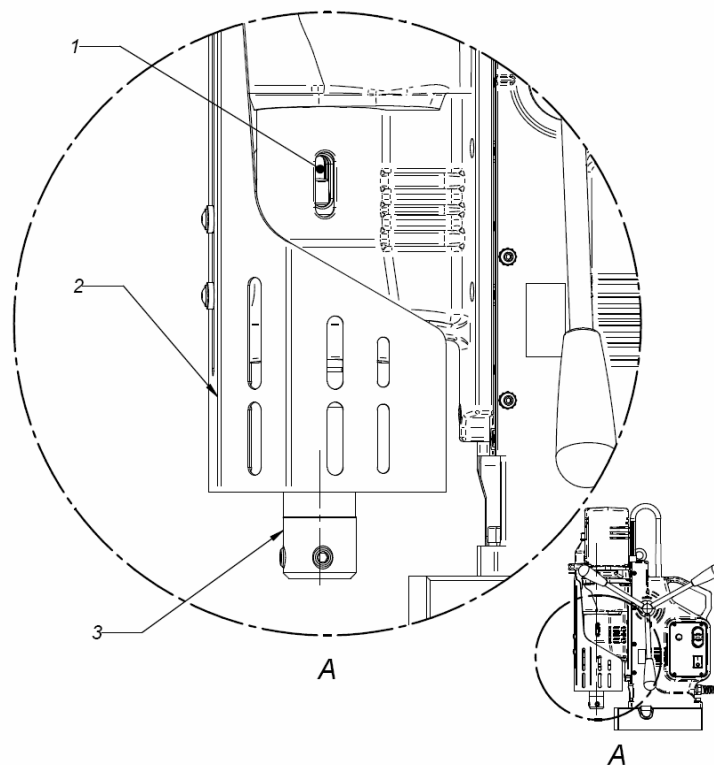

Uninstalling the arbor:

- a) Raise the guard, turn the spindle so that the wedge MT opening in the spindle (1) is lined up with the wedge MT opening in the reducer body,
- b) Place the wedge MT (included as standard equipment) into the uncovered spindle opening (1),
- c) Hold down the arbor (3) with one hand,
- d) Strike the wedge MT lightly with a hammer, taking care to not to damage the arbor,
- e) Carefully remove the arbor from the socket in the spindle,
- f) Remove the wedge MT.

1.2 Installing and uninstalling the milling cutter



Milling cutter installation and uninstallation should be carried out when the machine is turned off and disconnected from the power grid!

Installing the milling cutter:

1. Raise the drive and the slide (2) up using the lever (3);
2. Raise the guard (1) to the maximum in order to attain access to the arbor (4) screws (5);
3. Insert the appropriate type of pilot (6) into the milling cutter (7);
4. Position the milling cutter (7) with the Weldon shank facing up, so that the flat sides of the milling cutter are aligned with the screws (5)
5. Put the milling cutter (7) into the arbor socket (4);
6. Tighten the screws securely (5).

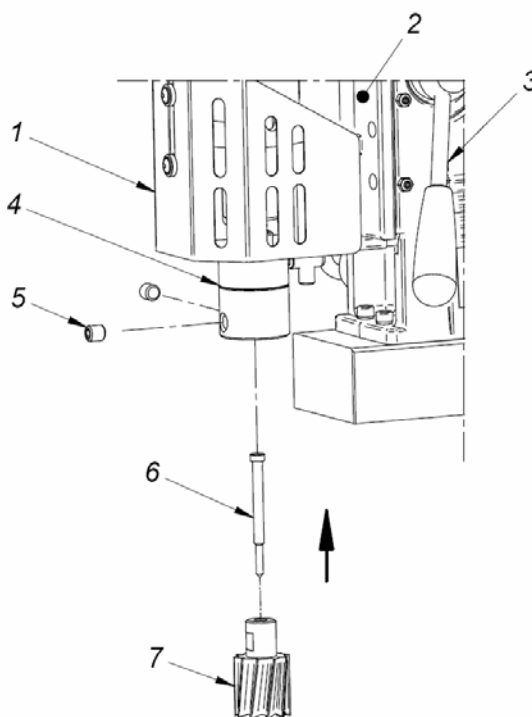

Uninstalling the milling cutter:

1. Raise the drive and the slide (2) up using the lever (3);
2. Raise the guard (1) to the maximum in order to attain access to the arbor (4) screws (5).
3. Loosen the screws (5);
4. Remove the milling cutter (7) and the pilot (6) from the arbor socket (4).

2. Magnetic drilling machine start up

The machine is supplied in a metal box with complete standard equipment.

D4X comes in a standard equipment set which consists of:

• metal box	1pc
• drilling machine	1pc
• arbor SM-AMT4-U-19 4-3	1pc
• cooling system	1pc
• chip guard	1pc
• spoke handles	3pcs
• Hex. Wrench s=2,5	1pc
• Hex. Wrench s=4	1pc
• Hex. Wrench s=5	1pc
• Hex. Wrench s=6	1pc
• 8 mm flat wrench	1pc
• wedge, MT4	1pc
• safety chain with snap hook	1pc
• operator's manual	1pc

2.1 Before first drill:

- The steel elements of the drilling machine are protected for transit and storing with grease film. Before first start up of the machine all grease should be removed
- Before each use all handles should be screwed into pinion.

2.2 Before you cut

Before positioning the machine on work piece always make sure that:

- Work piece is made of ferromagnetic steel (some grades of stainless or acid resistant steel do not readily conduct magnetic flux)
- thickness of work piece is at least 3/8" (10 mm)
- surface of steel under the magnet is flat
- wipe, brush or sand down to clean the surface where you intend to place the drilling machine, so that you remove rust, paint, dirt etc which would reduce adhesive power of the electromagnetic base.

Install drill bit, milling cutter or other tooling such as tap or reamer in the machine before plugging it into electric power. Then plug it in (see paragraph 2) and position where you wish to use it. Place the machine so that the tool is over the centre of the hole you intend to drill and turn the magnetic base ON.

Prior to use always make sure that the machine is secured from dropping with original chain (as described in paragraph I no. 5 “Important rules of safe use of drilling machine”).

2.3 Cutting

- Select the right speed for the tool you intend to use (see the speeds chart in this manual – paragraph IV no.1).

Cooling and lubricant fluid commercially available in concentrated form are recommended for cooling twist drills and annular cutters.

The use of emulsions formed from a mixture of water and drilling oil are acceptable.



Do not use clean water as the liquid cooling and lubricant.

The cooling system is an integral part of the machine and should always be used. (see point 2.7)

Warning: The cooling system can only be used when drilling machine is in vertical position. In other positions an additional external source of cooling should be used, for example: a coolant bottle with a long nozzle or a pressurized system.

- Check the operation of the cooling system. Open coolant reservoir's tap and apply pressure on the pilot by turning spokes counter clockwise. As the pilot starts to sink into the cutter cooling liquid should start to run down cutters inner wall. If there is no liquid flowing down check if the tap is fully opened. It may take a few seconds for cooling liquid to fill the whole system.

- Turn the motor on.

Making a hole with a milling cutter should ideally be done in one pass. The proper method is to put the motor under load in which it experiences about a 10% reduction in speed by listening to the sound it emits. It makes the cutter work better and more easily ejects the slug after the hole is completed. If you experience slugs getting stuck inside a cutter after the hole is complete try to reduce pressure on the cutter or use a different coolant. Do not allow excessive swarf build up around the cutter and arbor.

WARNING: when the milling cutter goes through the material the slug can be pushed out often with considerable strength. Pay attention to avoid injury.

- After a hole is made the cutter should be withdrawn back and both the motor and the electromagnet should be switched OFF in that order.

- When work with the machine is finished the power cord should be disconnected from the power source, the swarf and coolant should be cleaned from the machine and the cutter should be removed and cleaned.



Please follow all recommendations.

2.4 Cutting

1. Check working of cooling system. Open coolant reservoir's tap and apply pressure on the pilot by turning spokes counter clockwise. As the pilot starts to sink into the cutter cooling liquid should start to run down cutters inner wall. If there is no liquid flowing down check if the tap is fully opened. It may take a few seconds for cooling liquid to fill the whole system. (see point 2.8)
2. Turn the motor on.

WARNING: The cooling system can only be used when drilling machine is in vertical position. In other positions additional external source of cooling should be used, for example: a coolant bottle with a long nozzle or a pressurized system.

3. Start the engine by button " " on the control panel (see II point 3). Drilling in the material must be conducted with sensitivity.
4. Some of magnetic drilling machines have a built-in overload system. Overload is indicated by red LED diode on the control panel. Further increasing the engine load causes the activation of the overload system and power source loss. It's possible to continue the drilling operation by pressing the "O" MOTOR switch to reset the system and restart the engine. Periodic, uncommon illumination of LED's diode during the drilling process is normal. This means that the drilling process is used to the maximum extent of the permissible engine capacity.
5. Making a hole with a milling cutter should ideally be done in one pass. It makes the cutter work better and easier to eject the slug after the hole is completed.

WARNING: when the milling cutter goes through the material the slug can be pushed out often with considerable strength. Pay attention to avoid injury.

6. Do not allow excessively long chips (swarf) to accumulate that could interfere with the handles as this could be a safety hazard.
7. After a hole is made the cutter should be withdrawn back and both the motor and the electromagnet should be switched OFF in that order.
8. When work with the machine is finished the power cord should be disconnected from the power source, the machine should be cleaned of swarf and coolant etc. The cutter should be removed and cleaned.
9. The tool should be removed from drill chuck before returning to the toolbox.

2.5 Types of a ground material

As shown on the graphs [Drawing 4] magnetic clamping force of the electromagnetic base to the ferromagnetic ground depends on its magnetic properties. Steel with increased carbon content and some other alloying ingredients have lower magnetic permeability, which causes a decrease in the clamping force. Also the thickness of the work piece, on which the drill is placed, is significant.

Maximum clamping force of the electromagnetic base to a 5 mm (0.2") thick work piece surface is only about 25% of a clamping force obtained from a smooth 22 (0.87") mm thick standard plate.

If such thin ground material does not exist, one can try to carry out drilling of a hole, although with keeping the strictest precautions. The magnitude of force on the feed handle should be very limited.

Appropriate rpm should be adjusted depending on if drilling would be carried out with a drill bit, or with annular type metal cutter. The drill is equipped with a mechanical 2-step reducing gearbox. The general relationship between drilling diameter and drilling speed is shown in graphs [Drawing 5], and a detailed guide is supplied by the manufacturer of drilling tools. The graph is just a general guide and the shown relationship applies to average structural steel.

Cooling agent is fed gravitationally from a coolant bottle through an arbor to the inside of the metal cutter. For on-a-wall and on-a-ceiling positions special cooling pastes or aerosol sprays or pressurized coolant dispersal agents should be used.

2.6 Electromagnetic base clamping force control system

This system for security reasons is an integral part of each drill type. It works by constant monitoring of the electromagnetic force base adhesion value to the substrate. In the case of a reduction in the force value below safety limits to guarantee safe operation of the machine, the system automatically switches off the drive drill. It also does not allow the drive to be started when there is no guarantee of the proper clamping force.

Clamping force depends on: type and thickness of substrate, thick coatings on the substrate, rust or other contaminants, lack of flatness of the substrate, excessive roughness of the surface and excessive wear of the lower part of the electromagnetic base.

If the moto will not start after the magnetic base is clamped it means that the safety system is working properly. The system will not allow drilling without sufficient clamping force for personnel safety reasons.

2.7 Working in difficult areas

While working in difficult access areas as well as left-handed operator the pinions can be moved to the opposite side.

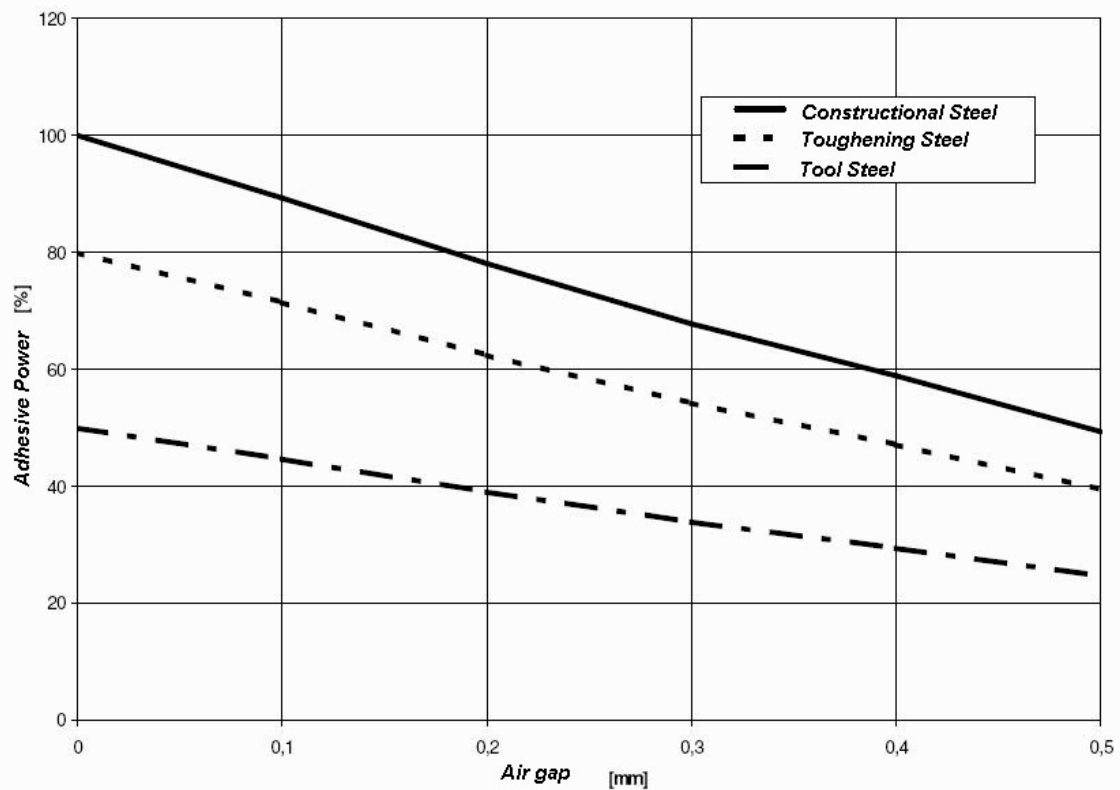
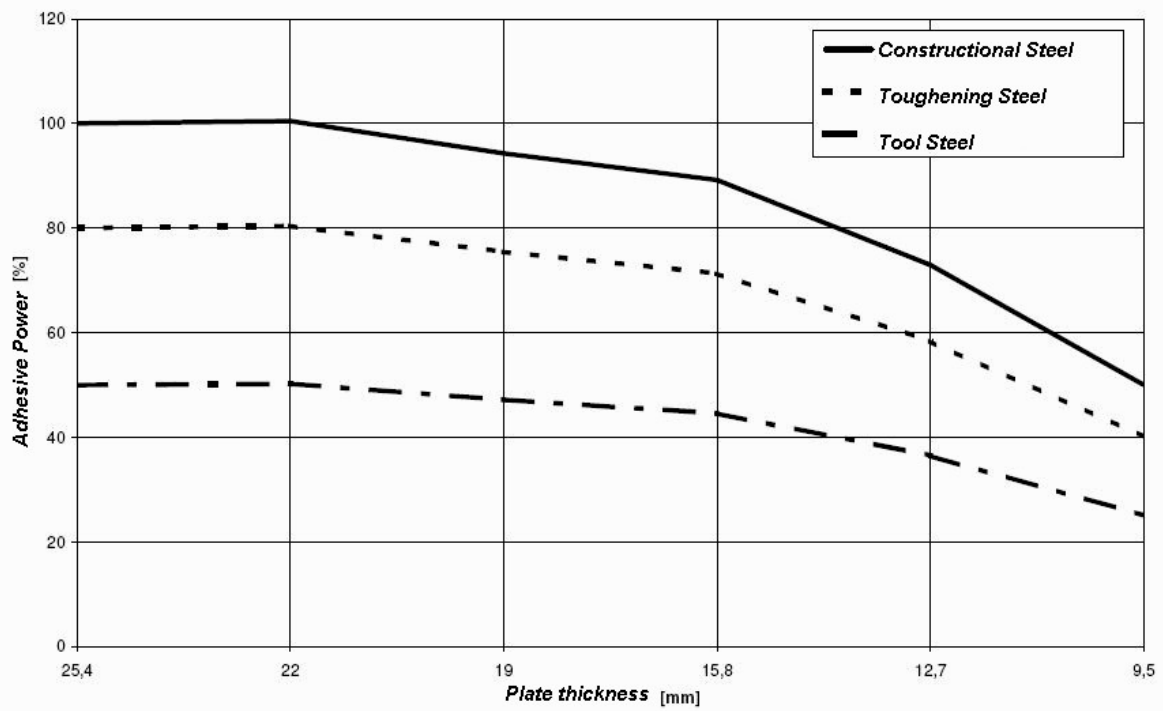

Drawing 4. Clamping force depending on the thickness of the substrate and the value gap.

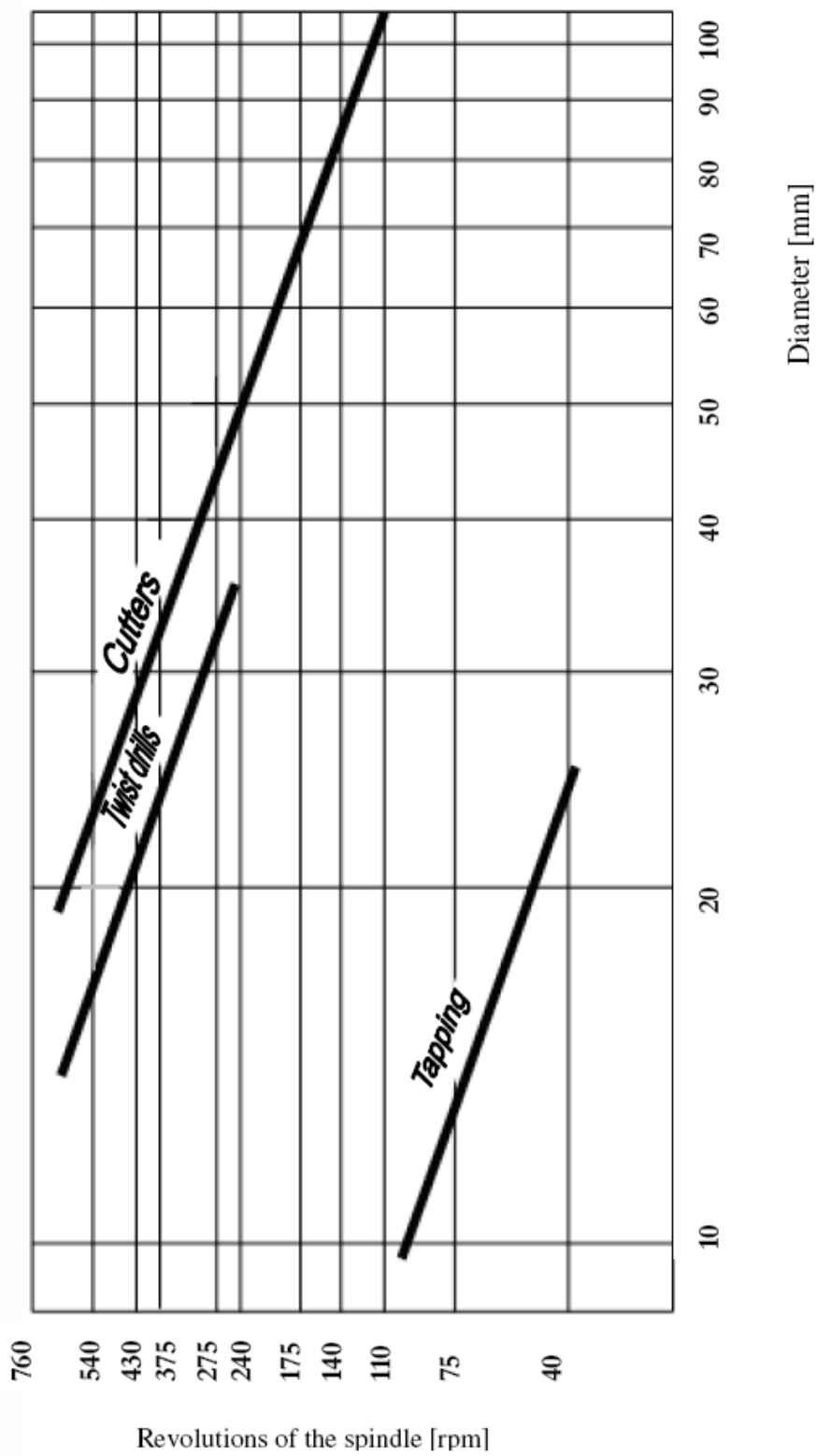

Drawing 5. Dependence of rotational speed on drilling diameter.

2.8 Installing and uninstalling the cooling system

Installing the cooling system:

- Place the machine in the vertical position,
- Slide the drive and the slider (1) up using lever (2),
- Coolant bracket (7) with cooling unit (6) on screws (8) located to the side of the slider,
- Connect the cooling conduit ending (3) with the coolant coupling (4) found in the cooling ring (5).

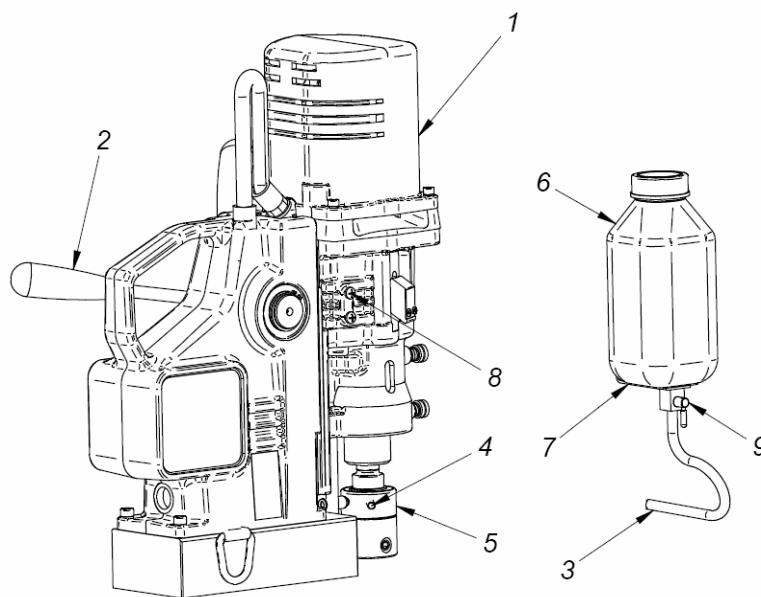

Before starting the machine:

- Remove the bottle's cap,
- Fill it with cooling lubricant,
- Replace bottle cap.

After fulfilling the above actions and making sure that the system has been appropriately fixed, and the cooling conduit (2) is placed correctly on the coolant coupling (4), the bottle cap should be loosened by 1/3 of a turn in order to depressurize it, turn on the valve (3), so that liquid travels to the hose, after which the machine can be started (see II pt. 3)

After ending work, one must remember to tighten the bottle cap and turn off the valve (9) (to prevent liquid from leaking during the time that the machine is not being used) and uninstall the cooling system (6) before placing the machine in the box.

Uninstalling the cooling system:

- Place the machine in the vertical position,
- Slide the drive and the slider (1) up using lever (2),
- Disconnect the cooling conduit ending (3) and the coolant coupling (4) found in the cooling ring (5).
- Take off the cooling system.

2.9 Canceling clearance

The drive and the slider can be moved up and down smoothly using the lever (1), making the screws (2) fixing the strip to the drill body visible through the openings in the slider (5). To loosen screws (2), the slider should be placed in such a position (using levers) so that the openings make the screws visible. After loosening the screws slide the slider up and down several times so that the pressure strip aligns itself and provides for smooth operation.

Canceling clearance

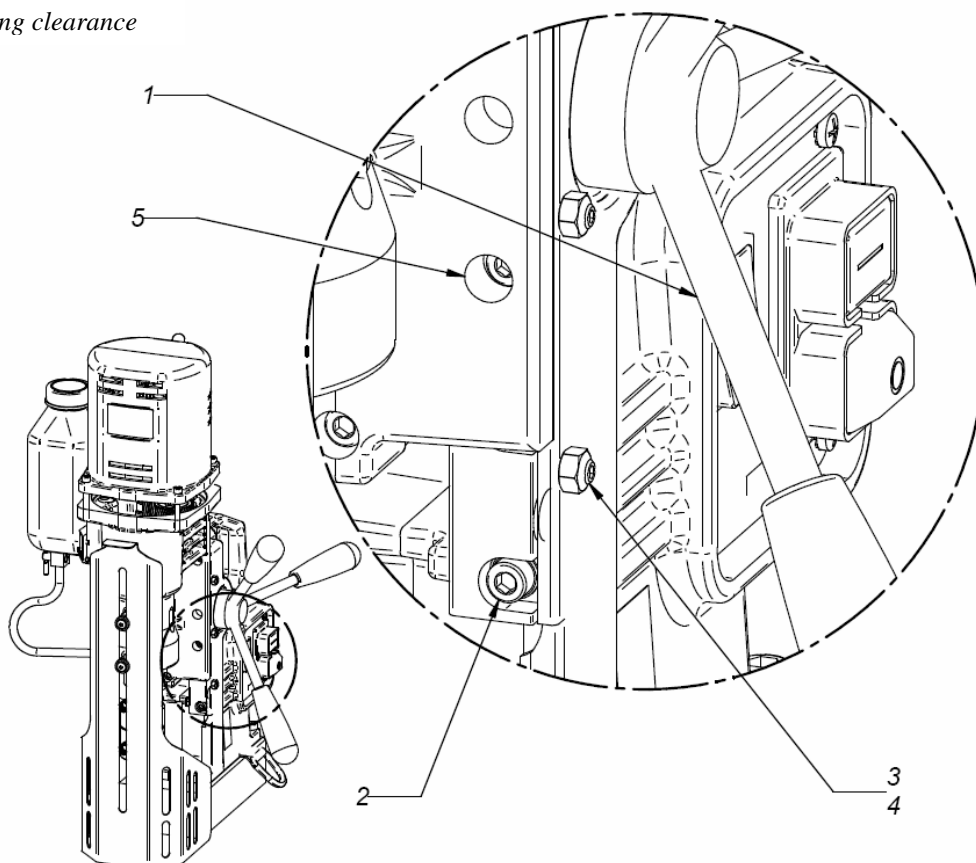

After carrying out these activities and canceling clearance, tighten screws (2) starting from the middle screw. The slider should be located symmetrically around the middle screw. Next, tighten the neighboring screws (2) by moving the slider in the degree necessary for making them visible.

Then, tighten screws (3) until any noticeable resistance is felt. When the screw in this position and blocked with a hexagonal key, tighten the outer counter nut (4). The screws (3) counteract the machining force and protect the pressure strip from shifting during operation.

3. Machine start-up

In order to start the machine press the main switch MAGNET (01) on “I” button. By pressing green button (02) MOTOR on “I” start the motor.

- Stopping the motor is executed with red button „O” (02) (the motor is switched OFF but the electromagnetic base is still ON) (02).
- Blinking of the red LED overload indicator (03) means that the machine is working at the limit of the overload. The machine can be automatically turned off at any time.
- To change the rpm speeds machine use the shift lever (04)

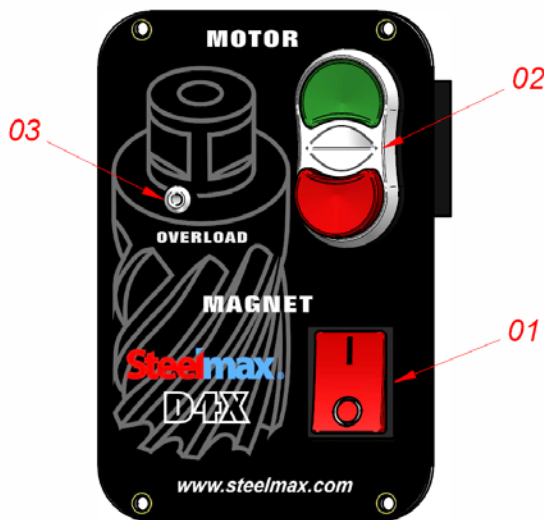

Drawing No.6 Control Panel

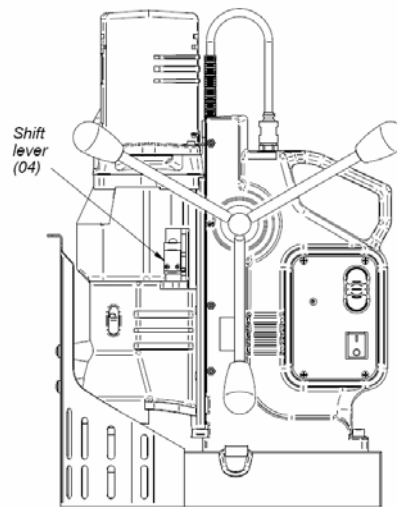

Drawing No.7 View of the machine D4X



To move machine into next drilling spot, stop the motor as described above then push switch MAGNET into the position “O”.

III. MAINTENANCE AND SERVICE

To avoid accidents the drill stand, power cable, wiring, plug connectors, switches must be regularly inspected for damage.

- Perform adjustment of the machine play guides every 50 hours or as necessary performed by the regulation screws. Slide guide tension is correct if the drive can be moved smoothly by using the lever. The slide should not slide down under it's own weight. (see II point 2.9)
- To facilitate the proper distribution of lubricant after every days work the position of the gear lever (used for selection of gearbox speed) should be changed. For example if the machine worked with 150 rpm speed, it should be switched to 300rpm. (see IV point.1).

- After every 250 hours of work check the condition of carbon brushes. If their length is less than 5 mm they should be replaced with original new ones. After replacement new brushes should be run-in without load for about 20 min. Other repair work should be done only by authorized service points, appointed by distributor. Replacement of brushes is possible without removal the of the motor unit from the unit. (see IV) Regularly lubricate brass slide guide inserts with grease as well as the rack and pinion.
- To prevent the machine from rusting (especially when used outdoors) all steel parts should be covered with thin layer of grease film
- Damaged machine parts will be exchanged only with original parts.

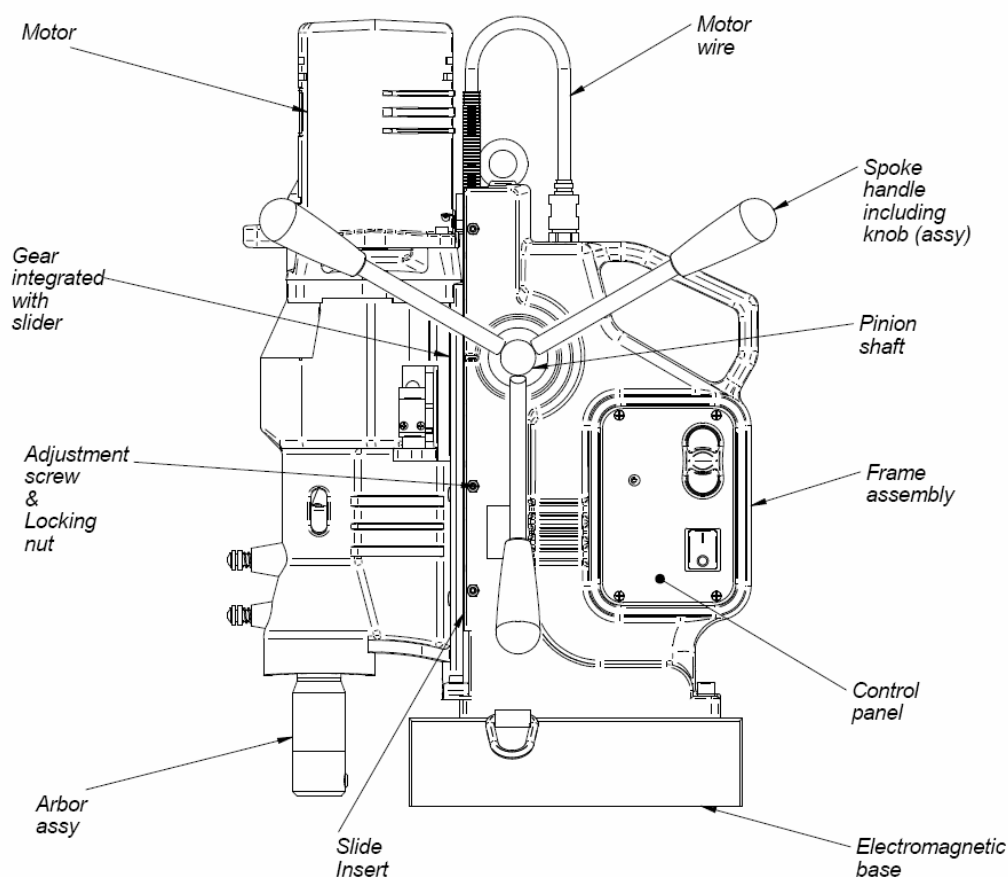

Caution:

In the case that the machine falls on a hard surface, from a height, is wet or is subjected to other adverse events that could affect its technical state - work should be terminated immediately and the machine should be sent to service for inspection as soon as possible.

IV. TECHNICAL DATA

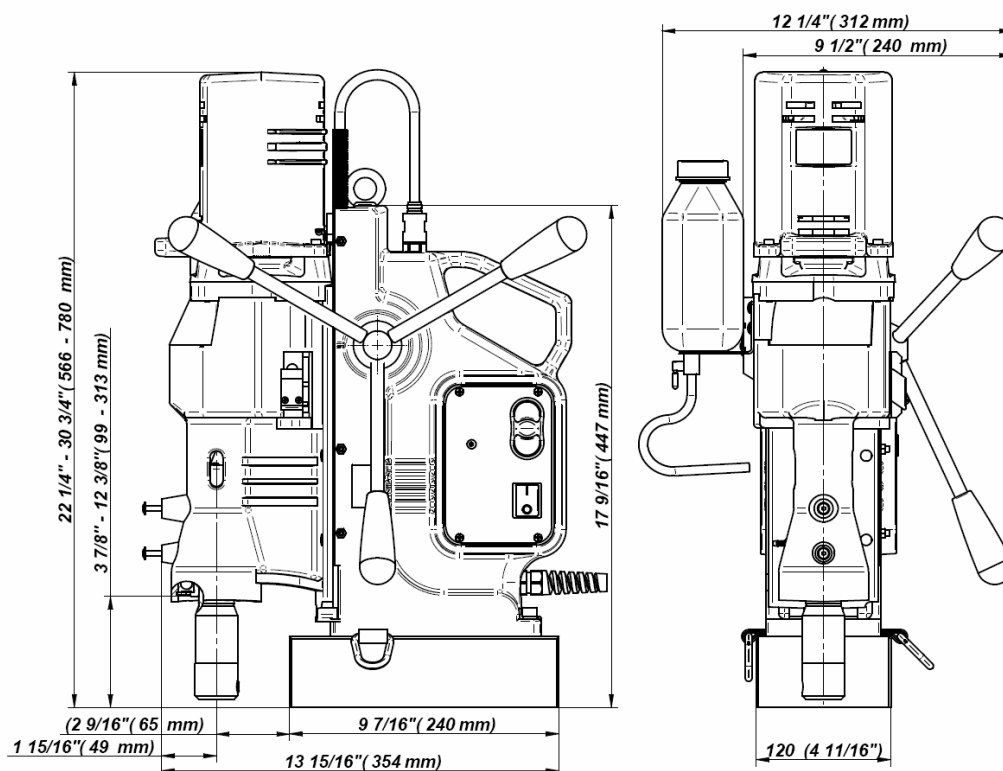

Power supply	<input type="checkbox"/> 110-120V AC / 50-60 Hz <input type="checkbox"/> 220-240V AC / 50-60 Hz
Power required	<input type="checkbox"/> 110-120V - 1700 W <input type="checkbox"/> 220-240V - 1800 W
Motor power	<input type="checkbox"/> 110-120V - 1550 W <input type="checkbox"/> 220-240V - 1650 W
Tool holder	Morse Taper No 4
Max. twist drill diameter	16-47 mm (5/8" - 1 7/8")
Max. annular drill diameter	12-110 mm (1/2" - 4 5/16")
Max. milling depth	76 mm (3")
Insulation Class	I
Standard adhesive force of electromagnet (for steel 7/8" (22 mm) thick and $R_a < 1,25$)	22 000 N
Slide stroke	230 mm (9")
Machine speeds /under load/	I – 85 min ⁻¹ , II – 135 min ⁻¹ III – 160 min ⁻¹ , IV – 250 min ⁻¹
Electromagnetic base	120x240x63 mm (4.7x9.4x2.5")
Length of the power cord	3,0 m (10")
Total weight	31 kg (68 lb)
Noise level	85 dB
Surrounding temperature	0 - 40° C (32-104° F)

Using the drill on the electromagnetic base D4X with special annular cutters we are capable of drilling and reaming holes up to 110mm (4-5/16") diameter and 76mm (3") depth with a precision achievable previously only in a workshop.

Replacement of motor brushes:

For the D4X drill, the state of the carbon brushes should be monitored every 100 working hours.



Replacement of motor brushes should take place when the machine is turned off and the power cable is disconnected from the power grid!

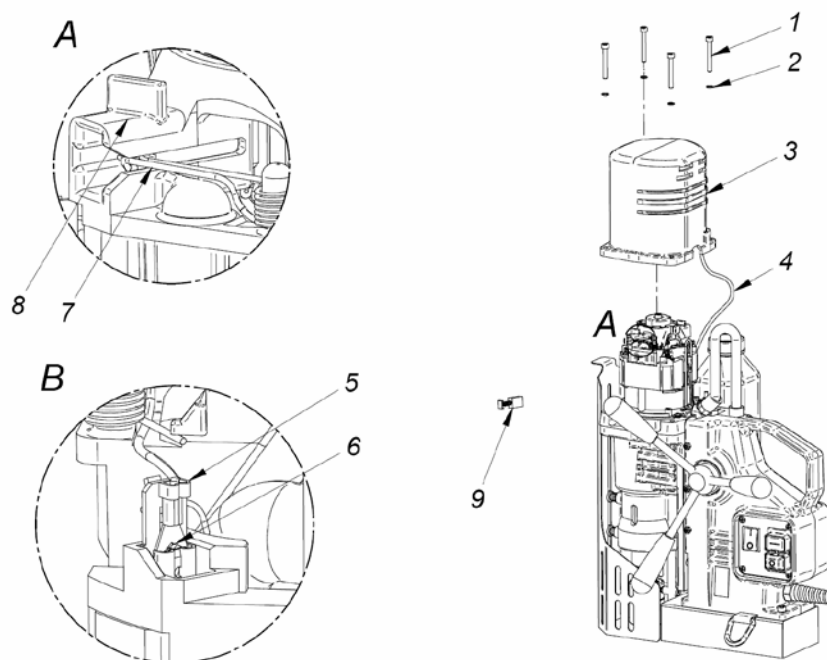

1. Unscrew 4 M5x40 engine cover screws (1), using a 6-kt s=4 wrench.
2. Carefully take off the engine cover (3). Remember that it is connected with the motor by a grounding lead (4).
3. Unplug the connector (6) from the motor brushes using the flat ending (5) of the lead. The ending has a safeguard against its sliding down – first, press the protruding element at the middle of the ending, then carefully slide off the ending from the connector.
4. Push aside the spring arm (7) pressing down the brush and rest it on the surface of the brush holder (8) and remove the brush (9).
5. Inspect brush length - if the length is less than 5mm, the brush should be replaced with an original brush.
6. Carry out all actions in reverse, in order to install the engine.

After replacement, new brushes should be run without load for about 20 minutes on idle gear in order to seat properly. Replacement of engine brushes is possible without removing the drive from the drill.

1. Parameters depending on spindle speed(drilling)

Due to the distribution of lubricant after every days work the position of gear lever (used for selection of gearbox speed) should be changed. For example if machine worked with 85 rpm speed, it should be switched to 250rpm. If machine worked with 135 rpm speed, it should be switched to 160 rpm.

Relationship between machine speed and cutter diameter

The cutter diameter		Rotary speed [rpm]
[inch]	[mm]	
under 2.95	above 75	85
1.93-2.95	50-75	135
1.14-1.93	30-49	160
0.47-1,14	12-29	250

Relationship between machine speed and twist drill diameter

The twist drill diameter		Rotary Speed [rpm]
[inch]	[mm]	
1.93-1.85	30-47	85
0.83-1.93	22-29	135
0.63-0.83	16-21	250

2. Guidelines for grading diameters of twist drills when drilling holes.

Drilling holes of a diameters greater than 18mm to 32mm (11/16 to 1-1/4") should be carried out by preliminary drilling where a diameter of a first hole should be between 70 to 80% of a final hole diameter. Holes greater than 32mm (1-1/4") should be drilled initially with a drill bit of a 18mm (11/16") diameter, then with a drill bit of a 80% of the diameter of a final hole, and finally with use of a drill bit with diameter of a desired size of finished hole. For example: When drilling a 23mm (7/8") diameter hole it is recommended to initially drill it using a drill bit of 16mm (5/8") in diameter and to increase a size of a tool gradually to reach a diameter of the desired hole; 40mm (1-9/16") hole should be drilled consecutively with drill bits of diameters: 18mm (11/16"), 32mm (1-1/4"), 40mm (1-9/16").

Holes diameter [mm]	Drills diameter [mm]			Number of passes
	Drilling	Expanding the hole by drilling	Expanding the hole by drilling	
for 18	for 18			1
18.1 - 32	70% final hole diameter	final hole diameter		2
32.1 - 40	Ø18	80% final hole diameter	final hole diameter	3

V. PARTS LIST/EXPLODED VIEW

WRT-0401-24-10-00-0			DRILLING MACHINE Steelmax D4X /120V	
WRT-0401-24-20-00-0			DRILLING MACHINE Steelmax D4X /230V	
ITEM	PART NUMBER	VERSION	DESCRIPTION	Q-TY
1	STJ-0401-01-00-00-0	1986	FRAME ASSEMBLY	1
2	NPD-0401-02-00-00-0	2488	MOTOR COMPLETE /120V	1
2	NPD-0401-02-00-00-1	1987	MOTOR COMPLETE /230V	1
3	MSK-0401-03-00-00-0	1991	PANEL PLATE ASSY	1
4	OSL-0401-04-00-00-0	2477	GUARD ASSY	1
5	ZSP-0401-05-00-00-0		ELECTRONIC CONTROL SYSTEM /120V	1
5	ZSP-0401-05-00-00-1		ELECTRONIC CONTROL SYSTEM /230V	1
6	TLJ-0399-06-00-00-0		LOWER SLEEVE,	2
7	WLK-0400-05-00-00-0		PINION SHAFT ASSY	1
8	DZW-0400-07-00-00-0		SPOKE HANDLE INCLUDING KNOB (ASSY)	3
9	UKL-0252-03-00-00-0		COOLANT SYSTEM	1
10	SZN-0075-00-51-00-5		POWER CORD 120V 3x2,08	1
10.4	DLW-000007		STRAIN RELIEF PG11	1
10	SZN-0212-10-02-00-2		POWER CORD 230V 3x1,5	1
10.4	DLW-000007		STRAIN RELIEF PG11	1
11	UCW-0173-01-00-00-0		ARBOR ASSY AMT4-U19/4-3	1
12	SPR-000030		PUSH SPRING,	2
13	WKR-000183		SCREW M4X10 PHCRMS	1
14	PRS-000019		EXTERNALE RETAINING RING 28z	1
15	PDK-000060		SPRING WASHER-4.3	6
16	PDK-000043		SPRING WASHER-4.1	5
17	PDK-000151		NYLON WASHER SR1940,	4
18	WKR-000395		SOCKET BUTTON HEAD CAP SCREW WITH FLANGE M5x20,	2
19	WKR-000184		CROSS RECESSED SCREW M4X12	4
20*	NKL-0272-15-00-00-0		LABEL FOR ELECTRICAL INSTALATION,	1
21	WKR-000415		CROSS RECESSED PAN HEAD TAPPING SCREW 3,5x13	4
22	PDK-000161		WASHER,LOCK,INTERNAL STAR 3,7	4
23*	ZST-0401-25-00-00-0	1992	EQUIPMENT SET	1
23.1*	LNC-0223-00-01-00-0		SAFETY CHAIN L=1,5 mb	1
23.2*	KLC-000005		HEX. WRENCH S=2,5	1
23.3*	KLC-000007		HEX. WRENCH S=4	1
23.4*	KLC-000008		HEX. WRENCH S=5	1
23.5*	KLC-000009		HEX. WRENCH S=6	1
23.6*	KLC-000003		FLAT WRENCH S=8	1
23.7*	KLN-0103-00-00-00-0		WEDGE MT3	1
23.8*	OPK-000001		PLASTIC BOX,	1
23.9*	INS-0239-46-00-00-5		SERVICE MANUAL	1
24*	SKR-0401-12-00-00-0	1673	METAL BOX	1
25*	NKL-0272-25-01-03-0		LABEL: WARRANT TO USE OF HEARING AND EYE PROTECTION	1
26*	NKL-0399-10-00-06-0		CLEARANCE CONTROL LABEL	1
27*	NKL-0401-10-10-04-0		LABEL FOR SIDE OF METAL BOX - small	1
28*	NKL-0401-10-10-05-0		LABEL FOR LID OF METAL BOX - big	1
29*	NKL-0300-25-06-02-0		LOGO LABEL	1

*not shown on the drawing

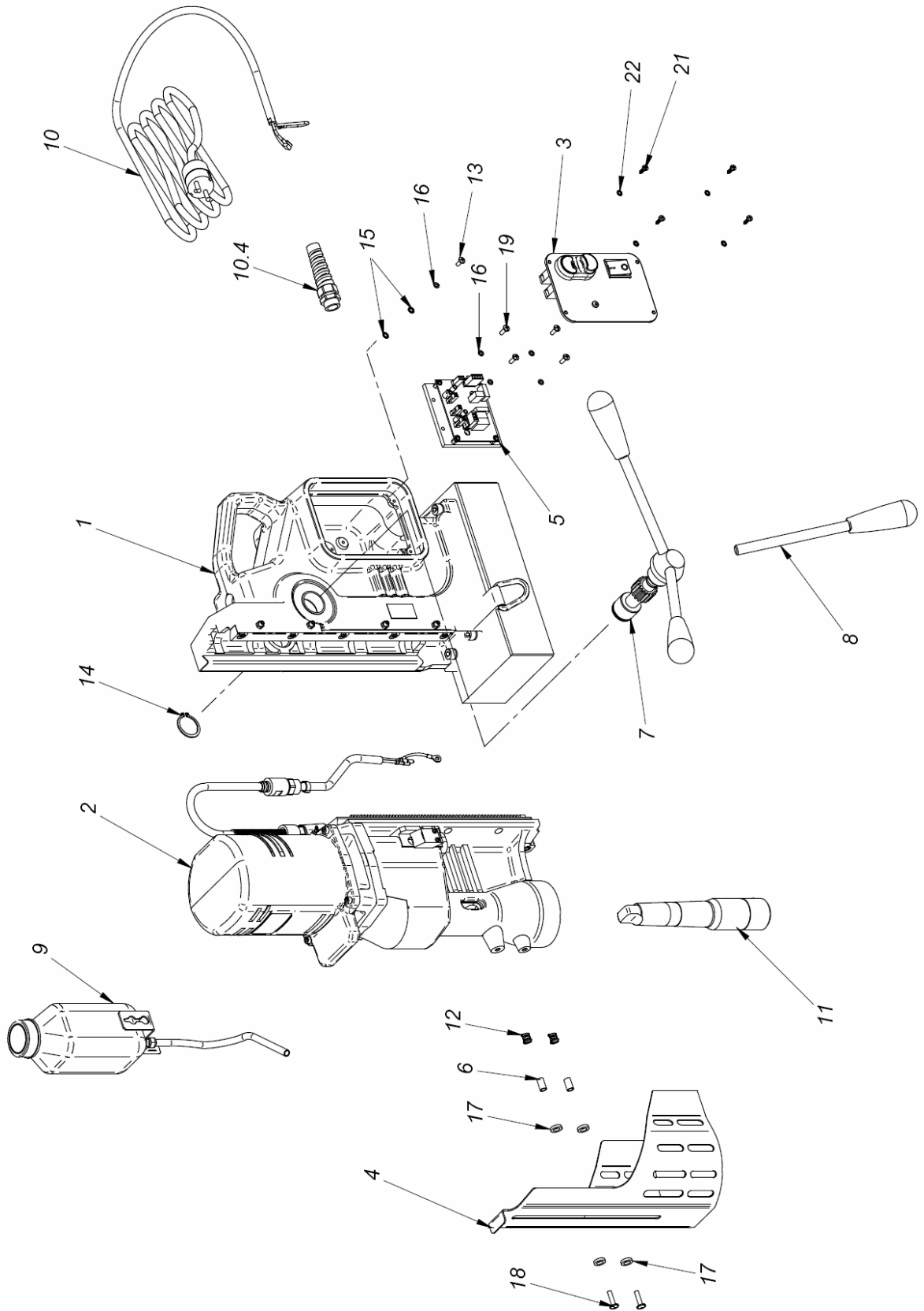

STJ-0401-01-00-00-0			FRAME ASSEMBLY	
ITEM	PART NUMBER	VERSION	DESCRIPTION	Q-TY
1.1	KRP-0400-01-01-00-0	1639	MAIN BODY ASSY	1
1.2	PDS-0402-00-00-00-0		ELECTROMAGNETIC BASE	1
1.3	PAS-0205-00-20-00-1		D-RING STRAP	1
1.4	SRB-000155		HEX. SOCKET BOLT M8x30,	4
1.5	PDK-000051		SPRING WASHER 8,2	4
1.6*	NKL-0400-10-10-02-0		FRAME LABEL	1

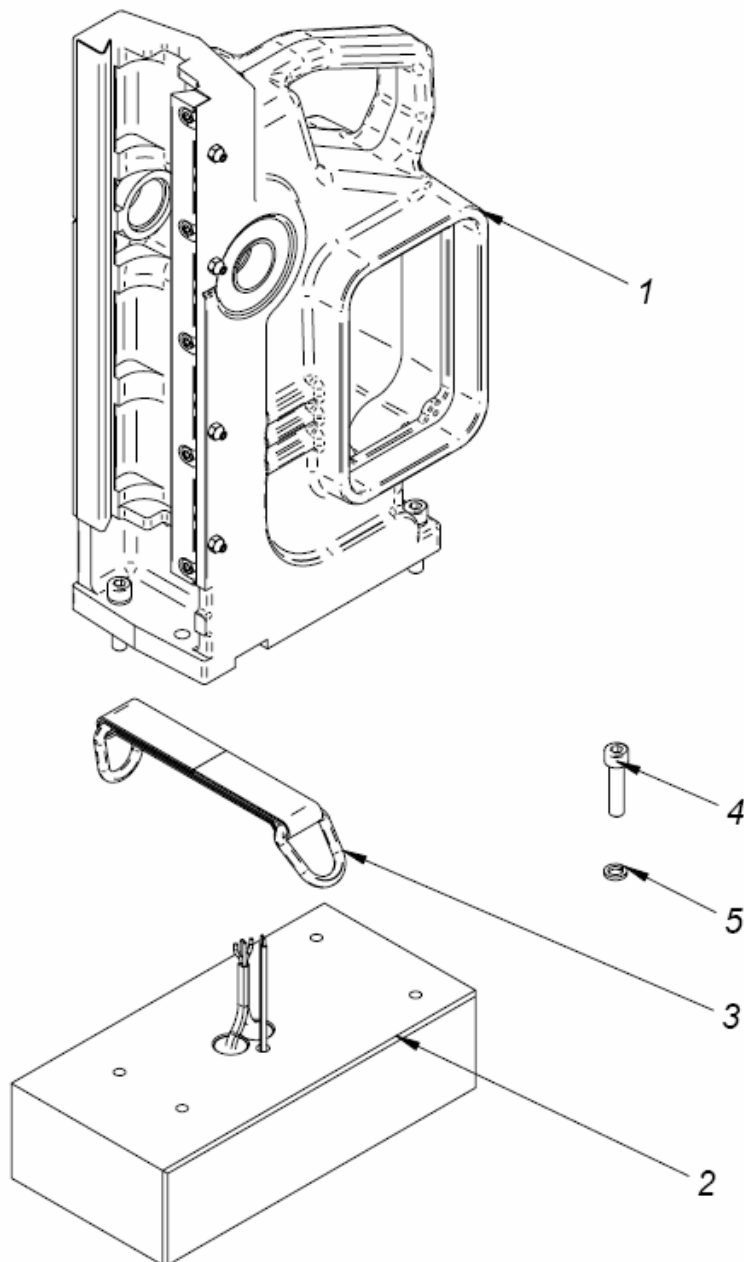

KRP-0400-01-01-00-0			MAIN BODY ASSY	
ITEM	PART NUMBER	VERSION	DESCRIPTION	Q-TY
1.1.1	KRP-0400-01-01-01-1	1636	MAIN BODY	1
1.1.2	LST-0400-01-01-02-0		PRESSURE PLATE	1
1.1.3	LST-0400-01-01-03-0		SLIDE INSERT	1
1.1.4	TLJ-000010		SELF LUBRICATING SLEEVE 28,05H7x32x16,	2
1.1.6	SPR-000043		PRESSURE SPRING 1,6x8x14,5	4
1.1.7	SRB-000086		HEX SOCKET BOLT-M5X20	5
1.1.8	PDK-000017		ROUND WASHER 5,3	5
1.1.9	NKR-000016		HEX. NUT M5	4
1.1.10	WKR-000077		SOCKET SET SCREW M5x16,	4

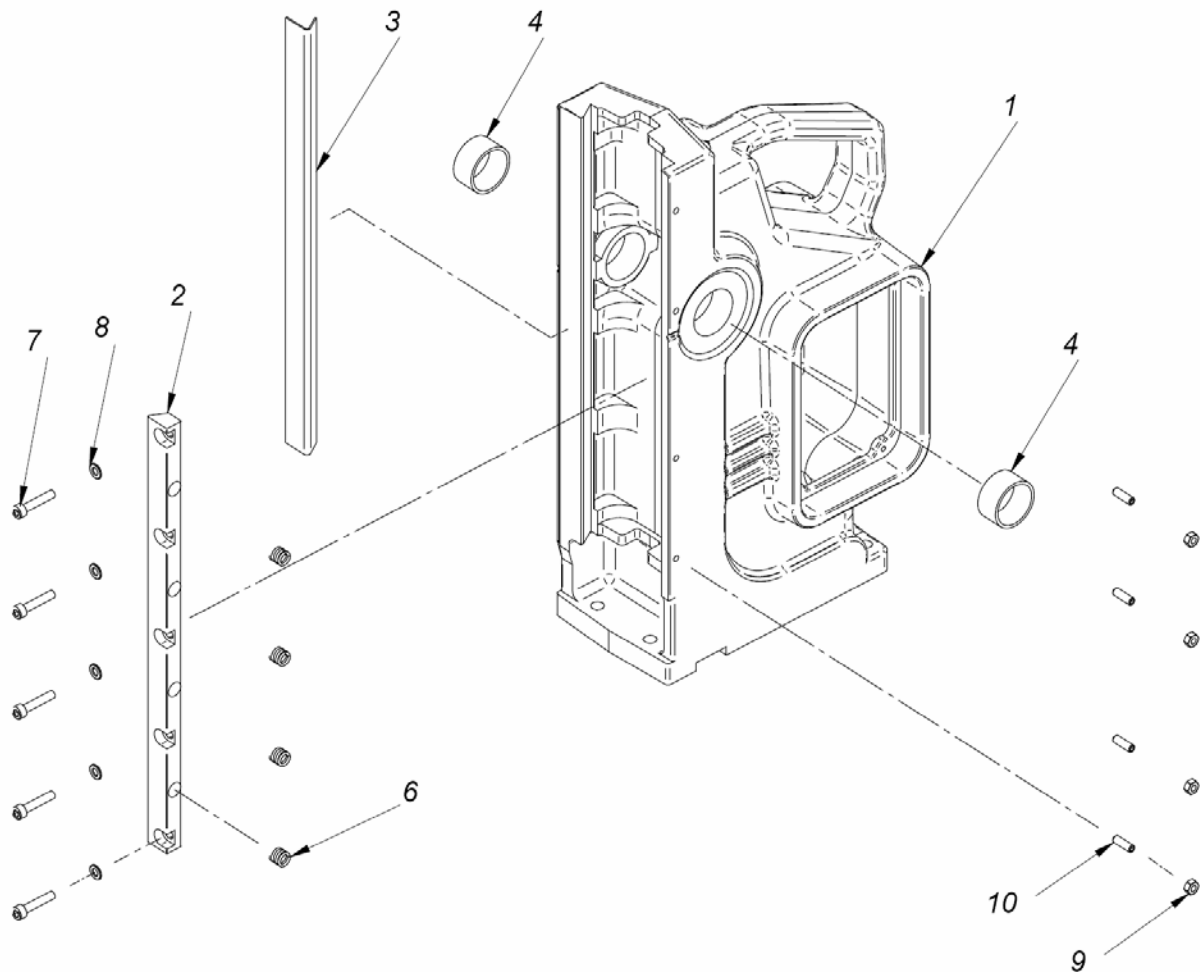

NPD-0401-02-00-00-0			MOTOR COMPLETE /120V	
NPD-0401-02-00-00-1			MOTOR COMPLETE /230V	
ITEM	PART NUMBER	VERSION	DESCRIPTION	Q-TY
2.1	SLN-0401-02-01-00-2		MOTOR /120V	1
2.1	SLN-0401-02-01-00-3		MOTOR /230V	1
2.2	KRP-0401-02-02-00-0	1644	GEARCASE ASSY	1
2.3	TLJ-0401-02-03-00-0		DISTANCE SLEEVE 25,1x31,8x4	1
2.4	KOL-0401-02-04-00-0		GEAR z46	1
2.5	WZK-0401-02-05-00-0		MOTOR WIRE ASSY	1
2.6	WLK-0401-02-06-00-0		PINION SHAFT z=20 ASSY	1
2.7	OBD-0400-02-03-00-1	1833	MOTOR HOUSING	1
2.8	LST-0400-02-06-00-0		GEAR RACK	1
2.10	WLK-0202-02-01-00-0		PINION SHAFT ASSY 14T,	1
2.11	WLK-0202-02-02-00-0		PINION SHAFT ASSY 19/25,	1
2.12	WLK-0202-02-04-00-0		PINION SHAFT ASSY z=14,	1
2.13	WDL-0211-00-28-00-1		SHIFT FORK	2
2.14	WLK-0202-00-16-00-1		SHIFT PIN SHORT	1
2.15	WLK-0202-00-17-00-1		SHIFT PIN LONG	1
2.16	PDK-0202-00-24-00-0		WASHER II	1
2.17	TBL-0202-00-30-00-1		LABEL I , SHIFT LEVER	1
2.18	TBL-0202-00-30-00-2		LABEL II , SHIFT LEVER	1
2.19	TLJ-0171-00-22-00-0		SHIFT DRIVE PIN (USA-5)	2
2.20	SPR-0171-00-23-00-0		COMPRESSION SPRING (USA 5)	2
2.21	DZW-0171-00-24-00-0		SHIFT LEVER	2
2.22	LOZ-000014		BEARING, NEEDLE RNA 4901	1
2.23	LOZ-000006		BEARING, NEEDLE RHNA 081210	3
2.24	LOZ-000007		NEEDLE BEARING RHNA 081512	1
2.25	LOZ-000004		NEEDLE BEARING HK 101410 CX	1
2.26	PRS-000017		EXTERNALE RETAINING RING 25z	1
2.27	PDK-000045		SPRING WASHER 5.1	2
2.28	PDK-000046		SPRING WASHER 6,1	2
2.29	PDK-000060		SPRING WASHER-4.3	1
2.30	KLK-000004		SPRING PIN 3x12	2
2.31	WKR-000180		SCREW M3x5 PHCRMS	4
2.32	WKR-000183		SCREW M4X10 PHCRMS	1
2.33	SRB-000091		HEX SOCKET BOLT M5x35 ,	2
2.34	SRB-000094		HEX. SOCKET BOLT M5x50	4
2.35	SRB-000115		HEX SOCKET BOLT-M6X25	2
2.36	WPS-0401-02-07-00-0		KEY SQ 6x6x22	1
2.37	PWD-0399-02-07-00-0		GROUND CONDUCTOR	1
2.38*	TBL-0401-10-10-03-0		MOTOR LABEL /120V	1
2.38*	TBL-0401-10-14-03-0		MOTOR LABEL /230V	1
2.39*	NKL-0401-10-00-06-0		LABEL "SPEED RANGE"	1

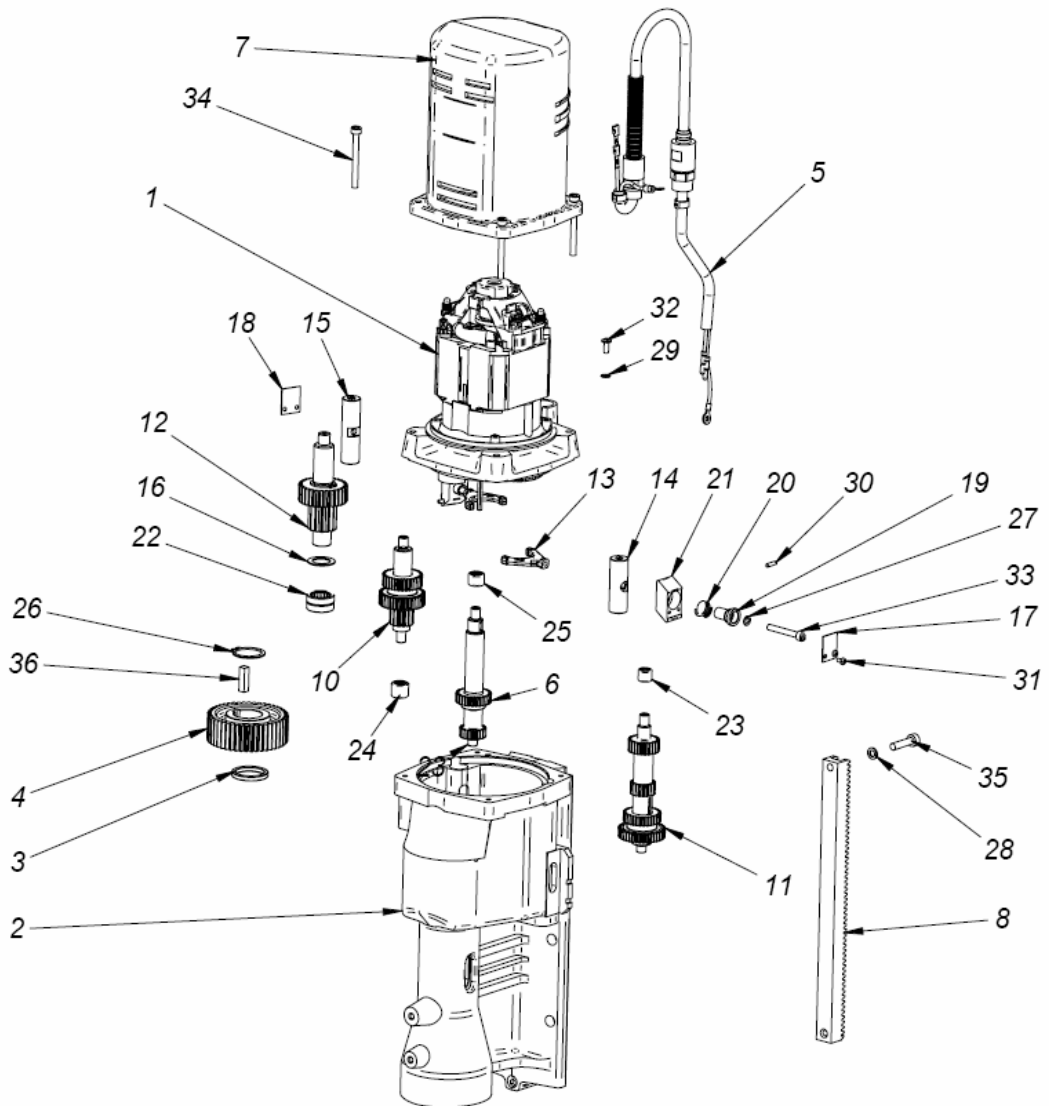

SLN-0401-02-01-00-2			MOTOR /120V	
SLN-0401-02-01-00-3			MOTOR /230V	
ITEM	PART NUMBER	VERSION	DESCRIPTION	Q-TY
2.1.1	PKR-0401-02-01-01-1		MOTOR COVER	1
2.1.2	KRW-0400-02-01-02-0		GUIDE FAN	1
2.1.3	WRN-0400-02-01-10-0		ARMATURE ASSY /120V	1
2.1.3	WRN-0400-02-01-10-1		ARMATURE ASSY /230V	1
2.1.4	KNC-0400-02-09-00-0		ARMATURE TOOTH END z8	1
2.1.5	STN-000028		FIELD /120V	1
2.1.5	STN-000029		FIELD /230V	1
2.1.6	OBD-000023		UPPER HOUSING	1
2.1.7	WKR-000407		CROSS RECESSED PAN HEAD TAPPING SCREW 4x20	4
2.1.8	PDK-000157		SPRING WASHER	1
2.1.9	SCZ-000023		BRUSH /120V	2
2.1.9	SCZ-000022		BRUSH /230V	2
2.1.10	SPR-000042		SPRING BRUSH	2
2.1.11	SRB-000295		HEXAGON BOLT M5x57	2
2.1.12	LOZ-000004		NEEDLE BEARING HK 101410 CX	1
2.1.13	LOZ-000006		BEARING, NEEDLE RHNA 081210	3

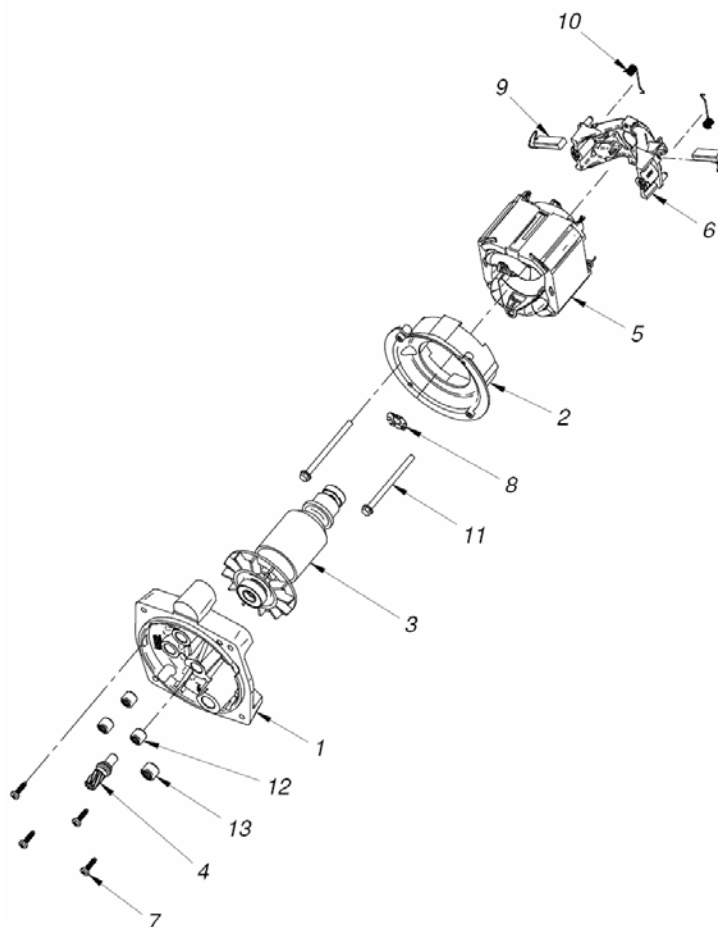

ELECTRICAL DIAGRAM

KRP-0401-02-02-00-0			GEARCASE ASSY	
ITEM	PART NUMBER	VERSION	DESCRIPTION	Q-TY
2.2.1	KRP-0401-02-02-01-1		GEARCASE	1
2.2.2	WRZ-0401-02-02-02-0		SPINDLE MT4	1
2.2.3	WST-0401-02-02-03-0		METAL INSERT	1
2.2.4	KNC-0234-00-10-00-0		COOLANT COUPLING AMT2-H-19	1
2.2.5	LOZ-000107		BEARING 6008 2Z 40x68x15	1
2.2.6	LOZ-000053		BEARING 608 2Z	2
2.2.7	LOZ-000017		BEARING, ROLL- 25x42x17	1
2.2.8	PRS-000245		SEAL 30x42x7	1
2.2.9	PRS-000246		SEAL 40x52x7	1
2.2.10	PRS-000247		SEAL 40x55x7	1
2.2.11	PRS-000139		INTERNAL RETAINING RING - 40z	1
2.2.12	PRS-000026		INTERNAL RETAINING RING - 42W	1
2.2.13	PRS-000244		INTERNAL RETAINING RING - 68W	1
2.2.14	KLK-000047		DOWEL, PIN 5 x 16 MM	1
2.2.15	SRB-000118		HEX. SOCKET BOLT M-6X30	1
2.2.16	WKR-000419		CROSS RECESSED RAISED COUNTERSUNK HEAD SCREW M5x10	2
2.2.17	KLK-000045		DOWEL, PIN 5 x 12 MM	1

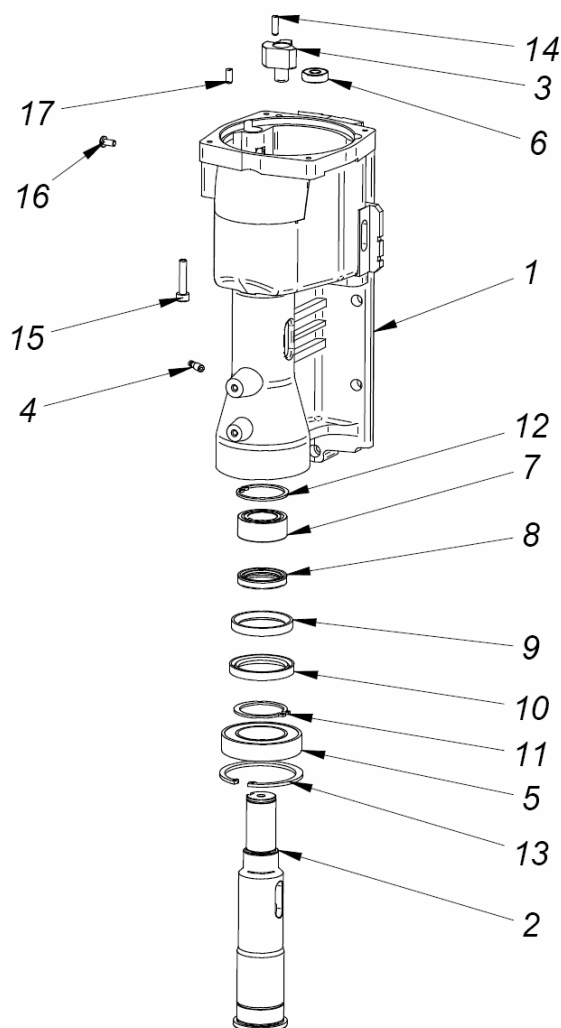

WLK-0401-02-06-00-0			PINION SHAFT z=20 ASSY	
ITEM	PART NUMBER	VERSION	DESCRIPTION	Q-TY
2.6.1	WLK-0202-00-07-00-0		GEARSHAFT, 20T	1
2.6.2	KOL-0202-00-06-00-0		GEAR, 29T	1
2.6.3	KOL-0401-02-06-01-1		HELICAL INPUT GEAR z45	1
2.6.4	WPS-0171-00-20-00-0		KEY,WOODRUFF #403	1

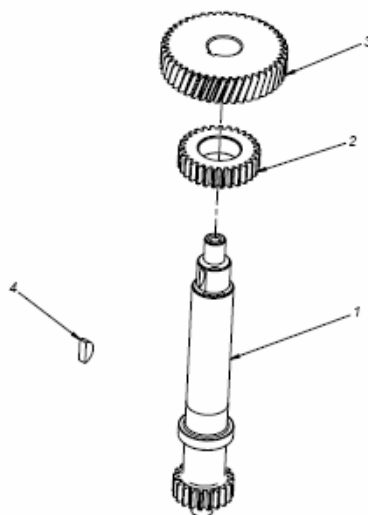

WLK-0202-02-01-00-0			PINION SHAFT ASSY 14T,	
ITEM	PART NUMBER	VERSION	DESCRIPTION	Q-TY
2.10.1	WLK-0202-00-11-00-0		SHAFT, PINION 14T	1
2.10.2	KOL-0202-00-10-00-0		GEAR, DUAL 33T / 39T	1
2.10.3	WPS-0202-00-20-00-0		KEY, SQ. 3X3X45	1

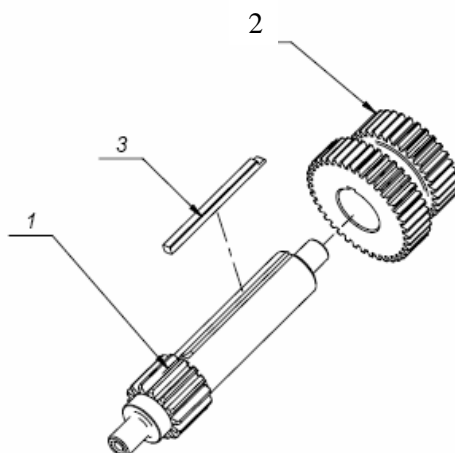

WLK-0202-02-02-00-0			PINION SHAFT ASSY 19/25,	
ITEM	PART NUMBER	VERSION	DESCRIPTION	Q-TY
2.11.1	WLK-0202-00-09-00-0		PINION SHAFT 19/25	1
2.11.2	KOL-0202-00-08-00-0		GEAR, DUAL 31T/42T	1
2.11.3	WPS-0202-00-21-00-0		SQUARE KEY 3X3X38	1

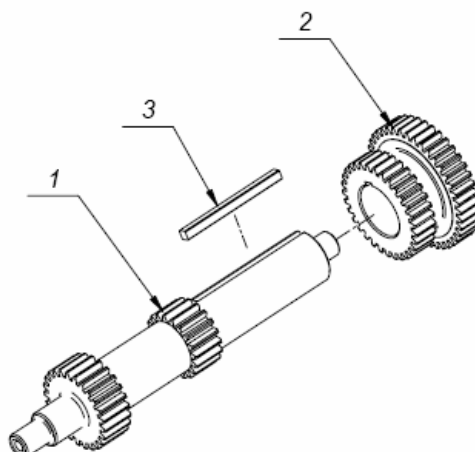

WLK-0202-02-04-00-0			PINION SHAFT ASSY z=14,	
ITEM	PART NUMBER	VERSION	DESCRIPTION	Q-TY
2.12.1	WLK-0202-00-13-00-0		GEARSHAFT 14-1.5 mm	1
2.12.2	KOL-0202-00-12-00-0		GEAR, 33T	1
2.12.3	WPS-0202-00-19-00-1		SQUARE KEY 5x5x12	1
2.12.4	PRS-000008		EXTERNAL RETAINING RING- 18Z	1

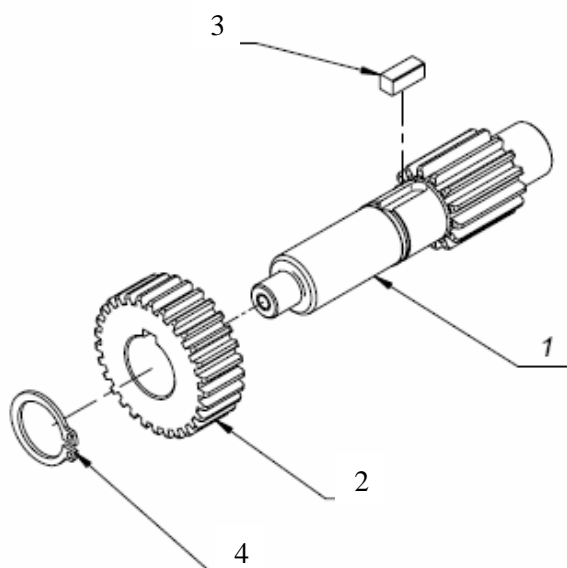

MSK-0401-03-00-00-0		1218	PANEL PLATE ASSY	
ITEM	PART NUMBER	VERSION	DESCRIPTION	Q-TY
3.1	MSK-0401-03-01-00-0		PANEL PLATE	1
3.2*	NKL-0401-10-10-01-0		LABEL PANEL PLATE	1
3.3	PRC-000007		SWITCH START-STOP,	1
3.4	WZK-0401-03-02-00-0		START-STOP WIRE	1
3.5	PNK-000013		SWITCH MAGNET	1
3.6	PEW-000002		LIGHT PIPE	1

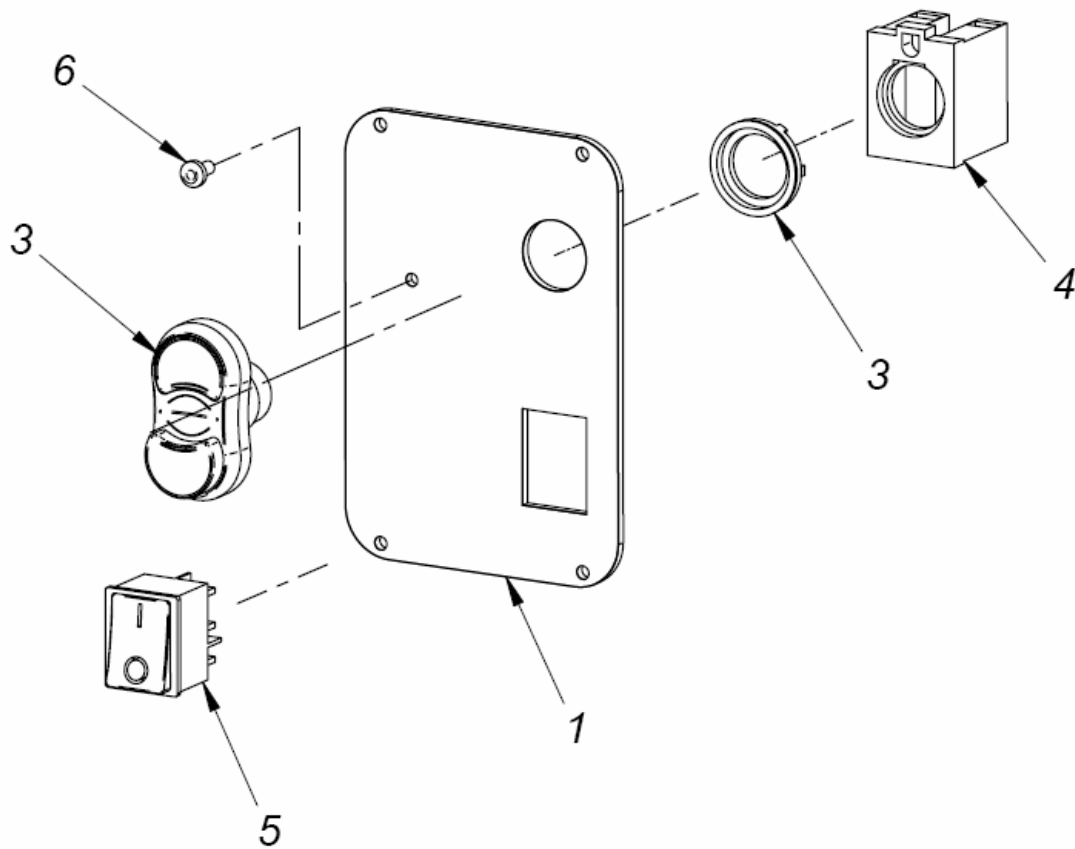

UKL-0399-11-00-00-0			COOLANT SYSTEM	
ITEM	PART NUMBER	VERSION	DESCRIPTION	Q-TY
9.1	ZWK-0399-11-01-00-0		COOLANT BRACKET	1
9.2	BTL-0252-04-00-00-0		BOTTLE,	1
9.3	PDK-0399-11-02-00-0		SEAL WASHER fi 9,5 x fi 15 x 2	1
9.4	ZWR-000010		COOLANT VALVE 1/8" ASSY WITH NUT	1
9.5	WAZ-000004		PLASTIC HOSE 4MM	0,27m

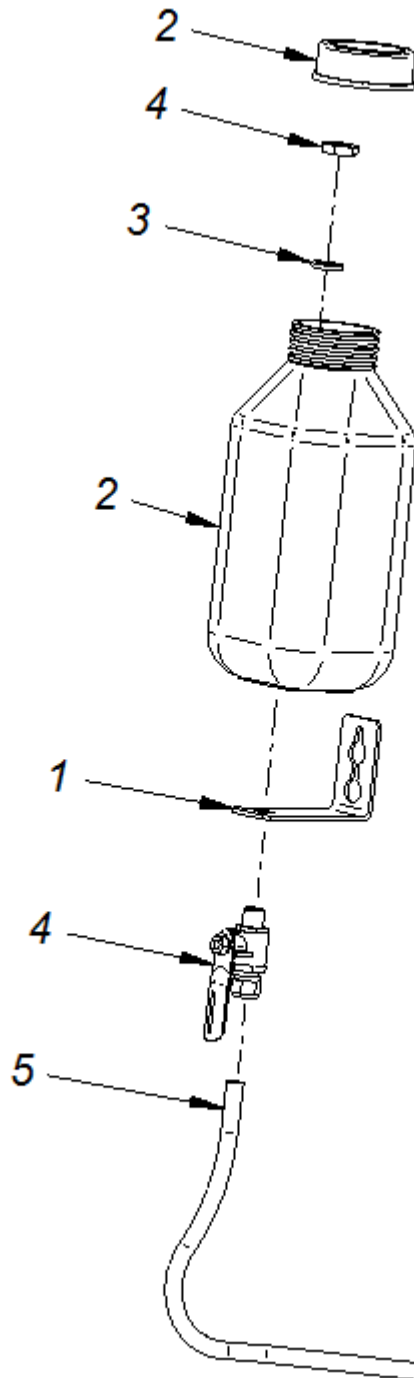

UCW-0173-01-00-00-0			ARBOR ASSY AMT4-U-19 /4-3	
ITEM	PART NUMBER	VERSION	DESCRIPTION	Q-TY
11.1	KRP-0173-01-01-00-0		ARBOR BODY AMT4-U-19 /4-3	1
11.2	WYP-0154-00-02-00-0		PLUNGER	1
11.3	PDK-0139-00-04-00-0		WASHER D=18,8x10x1	1
11.4	USZ-0140-05-04-00-0		SEAL	1
11.5	WKR-000032		HEX SET SCREW-M10X10	2
11.6	PRS-000009		INTERNAL RETAINING RING 19W	1
11.7	SPR-0154-00-03-00-0		SPRING 1,6x12,4x159	1

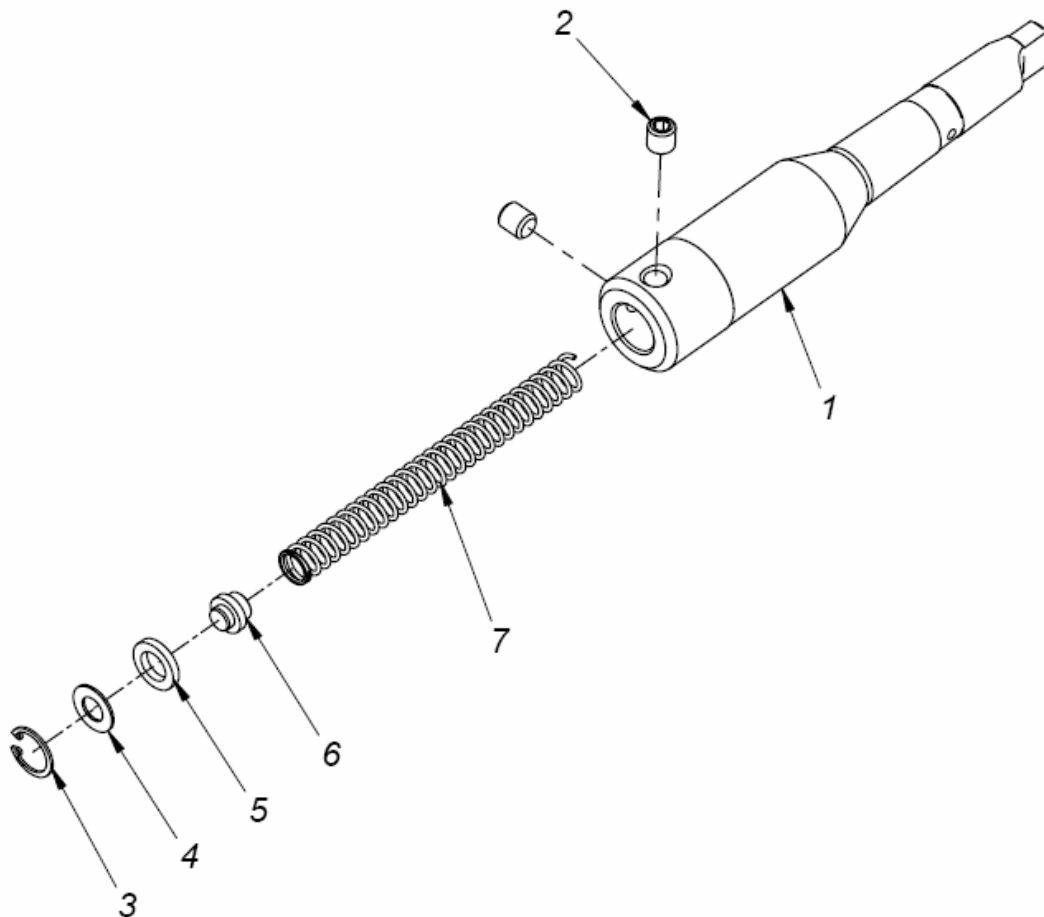

VI. Electrical diagram D4X /120V

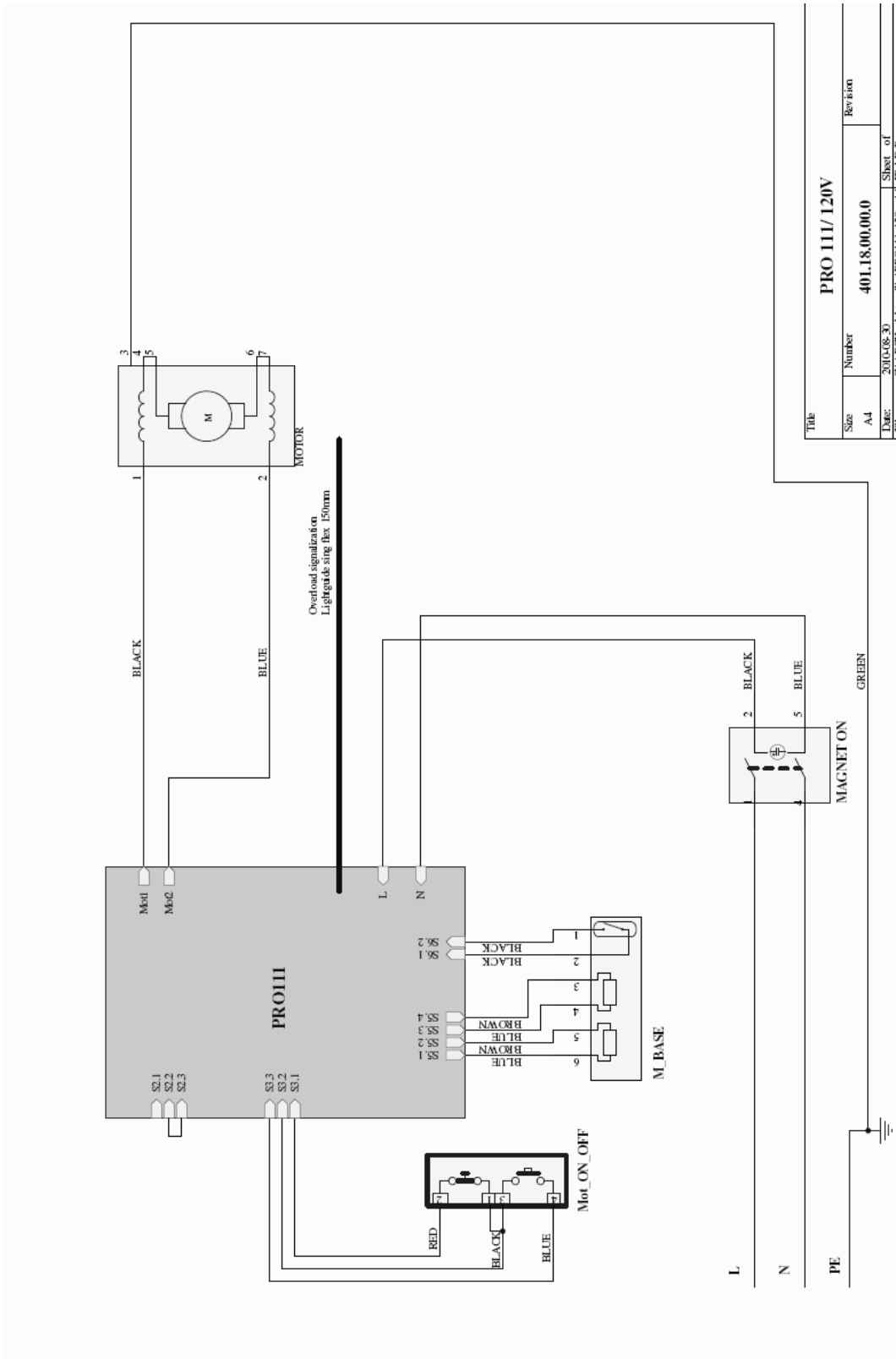

VI. Electrical diagram D4X /230V

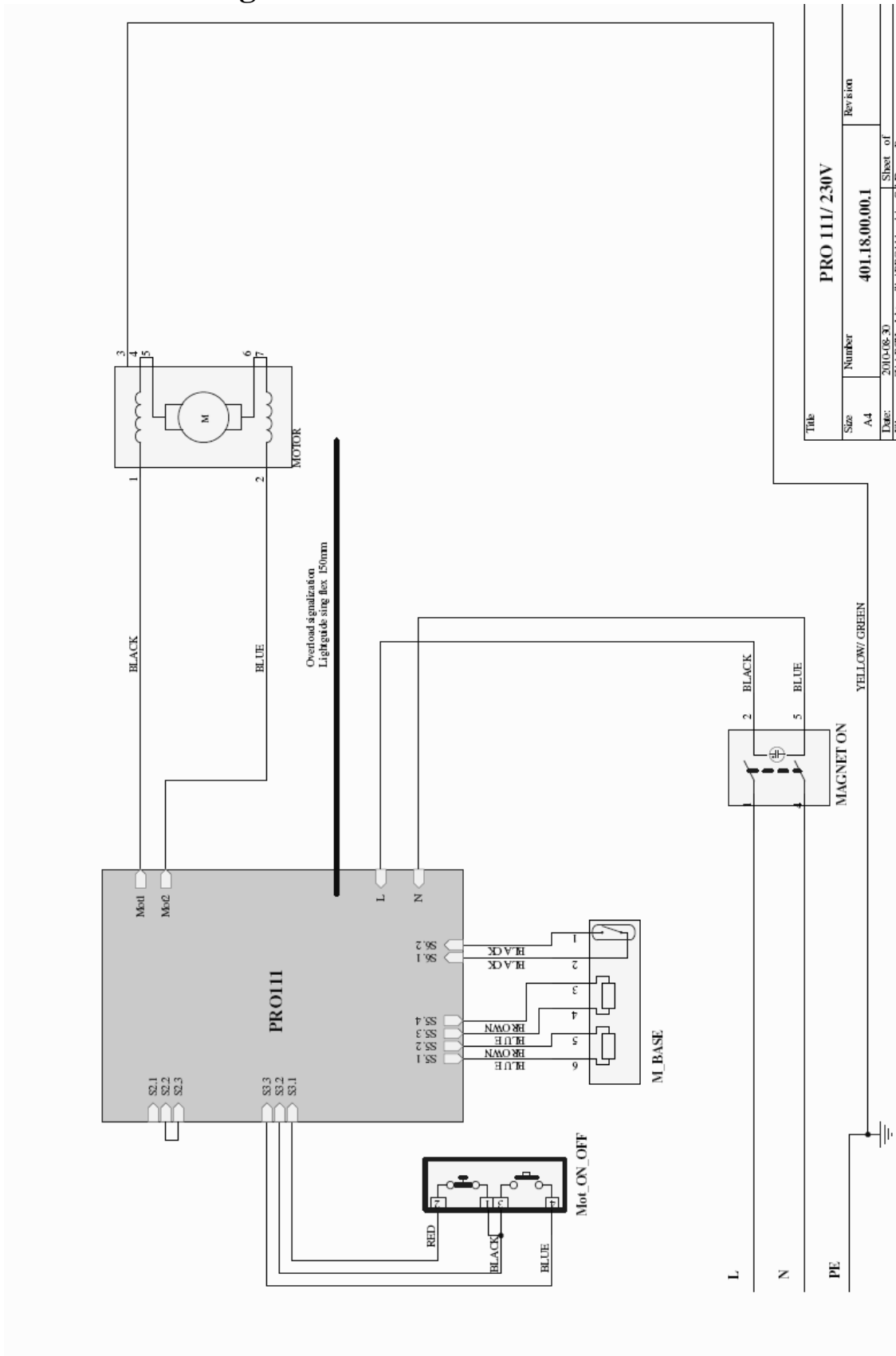

V. EC DECLARATION OF CONFORMITY

Declaration of compatibility

We

***PROMOTECH Ltd.
Elewatorska street 23/1
15-620 Bialystok, Poland***

declare with full responsibility that product:

D4X DRILLING MACHINE

which the declaration applies to is in accordance with the following standard(s) placed below:

EN 50144-1, EN 55014 and satisfies safety regulations of guidelines: 2004/108/EC,
2006/95/EC, 2006/42/EC.

Bialystok, 2009-10-15



Prezes

VI. MACHINE TEST CERTIFICATE

Machine control card

D4X /110V

D4X /230V

Serial No. _____

Date of test: _____

Electric test results:

Test	Result
Test with sinusoidal voltage of 1000 V and frequency 50 Hz	
Resistance of the protective circuit [Ω]	

The above-mentioned product meets the requirements of safe usage as prescribed in standard IEC-745

Name of tester _____

Quality Control _____

VIII. WARRANTY CARD

WARRANTY CARD No.....

..... in the name of
Manufacturer warrants the Drilling Machine to be free of defects in material and workmanship under normal use for a period of 12 months from date of sold.

This warranty does not cover cutters, damage or wear arises from misuse, accident, tempering or any other causes not related to defects in workmanship or material.

Date of Production Serial No

Quality Control:

Date of Purchase:

Signature of Seller.....

3/4" SHANK M2AL ANNULAR CUTTERS

M2AL Cutter Diameter	DECIMAL EQUIVALENT	1" D.O.C.	2" D.O.C.
		PART#	PART#
7/16"	0.4375	SM-AC-0438-1	SM-AC-0438-2
1/2"	0.5000	SM-AC-0500-1	SM-AC-0500-2
9/16"	0.5625	SM-AC-0563-1	SM-AC-0563-2
5/8"	0.6250	SM-AC-0625-1	SM-AC-0625-2
11/16"	0.6875	SM-AC-0688-1	SM-AC-0688-2
3/4"	0.7500	SM-AC-0750-1	SM-AC-0750-2
13/16"	0.8125	SM-AC-0813-1	SM-AC-0813-2
7/8"	0.8750	SM-AC-0875-1	SM-AC-0875-2
15/16"	0.9375	SM-AC-0938-1	SM-AC-0938-2
1"	1.0000	SM-AC-1000-1	SM-AC-1000-2
1-1/16"	1.0620	SM-AC-1063-1	SM-AC-1063-2
1-1/8"	1.1250	SM-AC-1125-1	SM-AC-1125-2
1-3/16"	1.1870	SM-AC-1188-1	SM-AC-1188-2
1-1/4"	1.2500	SM-AC-1250-1	SM-AC-1250-2
1-5/16"	1.3120	SM-AC-1313-1	SM-AC-1313-2
1-3/8"	1.3750	SM-AC-1375-1	SM-AC-1375-2
1-7/16"	1.4370	SM-AC-1438-1	SM-AC-1438-2
1-1/2"	1.5000	SM-AC-1500-1	SM-AC-1500-2
1-9/16"	1.5620	SM-AC-1563-1	SM-AC-1563-2
1-5/8"	1.6250	SM-AC-1625-1	SM-AC-1625-2
1-11/16"	1.6870	SM-AC-1688-1	SM-AC-1688-2
1-3/4"	1.7500	SM-AC-1750-1	SM-AC-1750-2
1-13/16"	1.8120	SM-AC-1813-1	SM-AC-1813-2
1-7/8"	1.8750	SM-AC-1875-1	SM-AC-1875-2
1-15/16"	1.9370	SM-AC-1938-1	SM-AC-1938-2
2"	2.0000	SM-AC-2000-1	SM-AC-2000-2
2-1/16"	2.0620	SM-AC-2063-1	SM-AC-2063-2
2-1/8"	2.1250	SM-AC-2125-1	SM-AC-2125-2
2-3/16"	2.1870	SM-AC-2188-1	SM-AC-2188-2
2-1/4"	2.2500	SM-AC-2250-1	SM-AC-2250-2
2-5/16"	2.3120	SM-AC-2313-1	SM-AC-2313-2
2-3/8"	2.3750	SM-AC-2375-1	SM-AC-2375-2
14mm	0.5512	SM-AC-14-M-1	SM-AC-14-M-2
15mm	0.5906	SM-AC-15-M-1	SM-AC-15-M-2
16mm	0.6299	SM-AC-16-M-1	SM-AC-16-M-2
17mm	0.6693	SM-AC-17-M-1	SM-AC-17-M-2
18mm	0.7087	SM-AC-18-M-1	SM-AC-18-M-2
19mm	0.7480	SM-AC-19-M-1	SM-AC-19-M-2
20mm	0.7874	SM-AC-20-M-1	SM-AC-20-M-2
21mm	0.8268	SM-AC-21-M-1	SM-AC-21-M-2
22mm	0.8661	SM-AC-22-M-1	SM-AC-22-M-2
23mm	0.9055	SM-AC-23-M-1	SM-AC-23-M-2
24mm	0.9449	SM-AC-24-M-1	SM-AC-24-M-2
25mm	0.9843	SM-AC-25-M-1	SM-AC-25-M-2
26mm	1.0230	SM-AC-26-M-1	SM-AC-26-M-2
28mm	1.1020	SM-AC-28-M-1	SM-AC-28-M-2
29mm	1.1410	SM-AC-29-M-1	SM-AC-29-M-2
31mm	1.2200	SM-AC-31-M-1	SM-AC-31-M-2