

Steelmax[®]

SAFETY INSTRUCTIONS AND OPERATORS MANUAL FOR BEVELLING MACHINE

SM-BM20

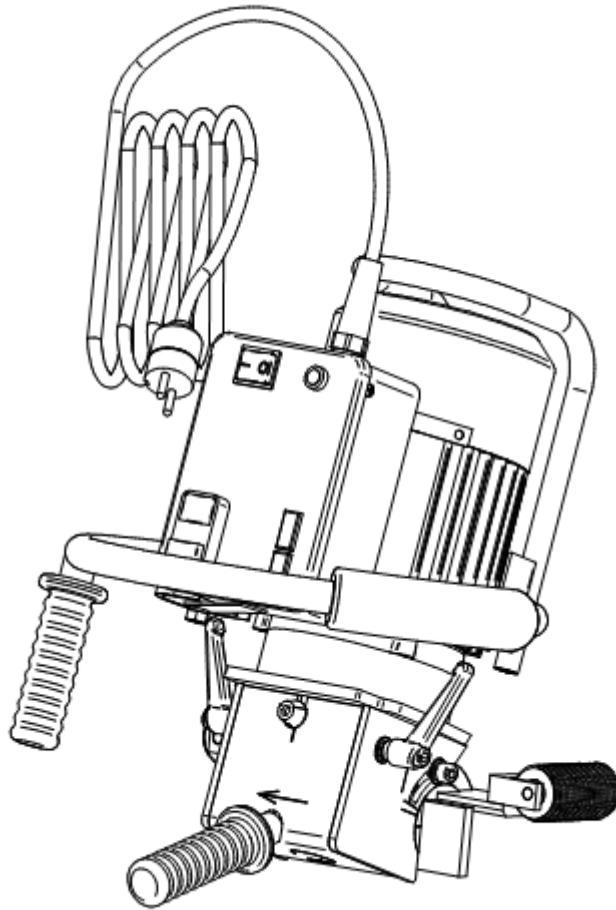

6200 S Troy Circle Suite 110 Centennial, CO 80111

1-87STEELMAX FAX 303-690-9172

www.steelmax.com

CONTENT

1. GENERAL INFORMATION	3
2. TECHNICAL DATA	4
3. STANDARD BEVELLING MACHINE EQUIPMENT	6
4. GENERAL SAFETY ADVICE	6
5. START UP AND OPERATION	9
6. BEVELLING PIPES	10
7. EDGES PLANNING WITH SET 0°	11
8. REQUIRED ANGLE AND WIDTH OF CUT SETTING	11
9. HOW TO CHANGE INSERTS	12
10. HOW TO CHANGE MILLING HEAD ASSY & MILLING HEAD ARBOR.....	14
11. HOW TO CHANGE GUIDE SET	16
12. PARTS LIST	17
13. ELECTRIC DIAGRAM	20
14. CE DECLARATION OF CONFORMITY	21
15. MACHINE'S TEST CERTIFICATE	22
16. WARRANTY CARD	23



**BEFORE YOU START WORK WITH THE MACHINE,
PLEASE READ THESE INSTRUCTIONS CAREFULLY
AND USE ALL RECOMMENDATION.**

1. GENERAL INFORMATION

The bevelling machine type BM-20 is designed for milling steel edges prior to welding. It is reliable and simple to use. The BM-20 machine can be used for bevelling straight steel sheets and pipes. It allows you to bevel steel edges between 15 and 60 degrees. Maximum face of bevel is 20 mm (3/4"). When equipped with special attachment it can also work on pipes above 150 mm (6") diameter.

Before you start work with the machine, please read these instructions carefully. Take special note of safety recommendations.

2. TECHNICAL DATA

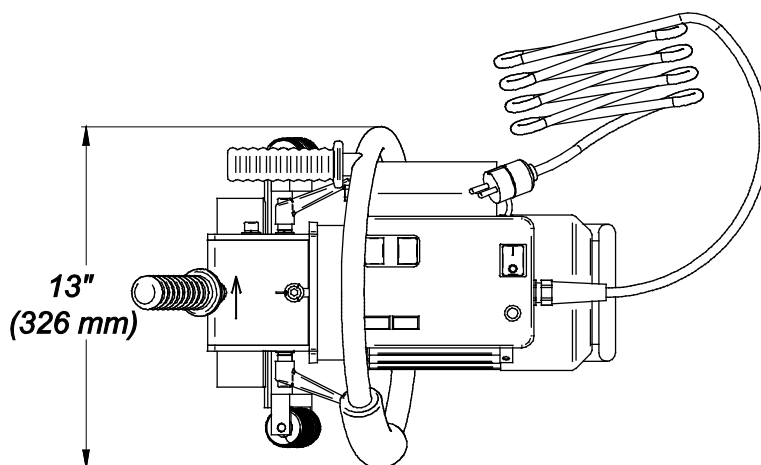
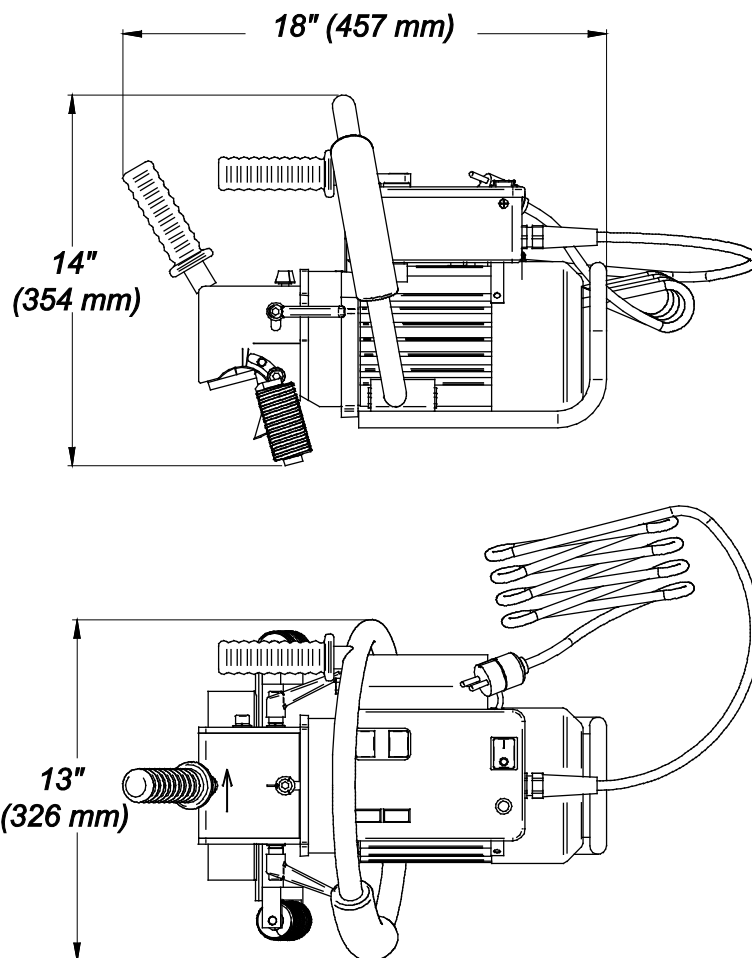

Drawing: BM20 dimensions

Power supply	<input type="checkbox"/> 110-120 V 50/60 Hz~ <input type="checkbox"/> 220-240 V 50/60 Hz~
Motor	electric, single phase, induction, with work capacitor
Power required	1.6 kW
Speed	2820 RPM
Electric safeguard	neutral earthing
Insulation Protection	IP 20
Cutting speed	approximately 1.5 m/min, 5 ft/min
Max. width of cut	$b = 20 \text{ mm (3/4")}$ – drawing. 1
Range of angles	$15^\circ < \beta < 60^\circ$ - drawing.1 - option 0°
Fuse	2 A / 250 V
Total weight	around 20.5 kg, 45 lbs.
Noise level	above 85 dB

Tool: double milling head with multi-blade inserts

Multi-blade inserts: BM-20 (CERMET thickness 3,10 mm (1/22")) - 12 pcs.

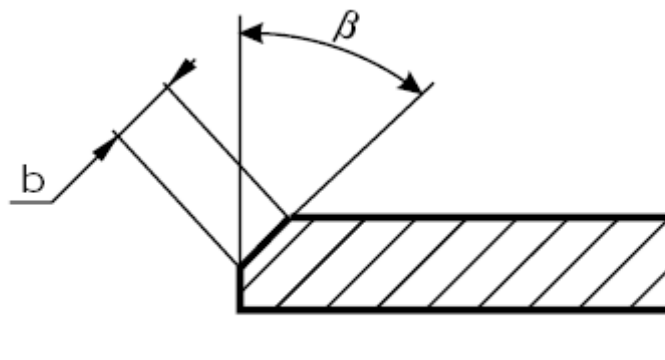

Drawing 1

3. STANDARD BEVELLING MACHINE EQUIPMENT

BM-20 comes in a set which consists of:

• Standard:		
metal box		1pc
beveling machine with a set of inserts		1pc
tool box	(part 601)	1pc
Allen wrenches hex s6	(part 602)	1pc
Allen wrenches hex s3	(part 604)	1pc
milling head fastening tool	(part 603)	1pc
milling head interlock	(part 605)	1pc
milling head puller	(part 606)	1pc
operators manual		1pc
locking screw		6pcs
• Optional:		
edges planning set 0°	(part 610)	1pc
pipe beveling attachment	(part 611)	1pc
pipe beveling attachment III-a	(part 612)	1pc

4. GENERAL SAFETY ADVICE

Beveling machine must not be used when:

1. The operator has not read the Operator's Manual.
2. The work to be done is not in agreement with the recommendations in this Manual.
3. The beveling machine is not complete or has been repaired with non-original parts.
4. The specifications of the power supply do not conform to those stated on the motor plate.
5. The operator has not checked the condition of the beveling machine, the condition of power cable, control panel and milling inserts.

6. The power supply socket is not equipped with a protection circuit.
7. Bystanders are present in the immediate vicinity of machine.

Important rules of safe use of bevelling machine

- 1) Before attempting to work with the machine, check the condition of electrics including power cord and plug.
- 2) The bevelling machine should be connected to an installation equipped with protection circuit (neutral or ground) and protected with a 16 A fuse for 220V and 32 A fuse for 120V. **When used on building sites, it must be supplied through a separation transformer made in the second class of protection**
- 3) Machine can be used outdoors, but it is not weatherproof. Do not expose to rain, snow or frost.
- 4) Do not use power cord for unintended purpose. Never carry the machine by cord or yank it to disconnect a plug from a socket.
- 5) Do not let power cord to be pulled tightly when in use. It threatens to break off power cord.
- 6) Do not use the machine in explosion hazard zones.
- 7) Always wear safety goggles and ear protection.
- 8) Do not remove metal chips with bare hands – they could be hot and sharp.

WARNING:

DO NOT CATCH ANY ROTATING MACHINE PARTS OR METAL CHIPS FORMING DURING MILLING WITH HANDS

- 9) Inserts must be fastened firmly using locking screw. Check tightness before each use.
- 10) If blade edge is worn or dull, turn blade by 90° in the milling socket or change to a new one indicated in Operator's Manual.
- 11) Use tools recommended in Operator's Manual only.
- 12) Always use proper tools recommended by manufacturer.
- 13) Damaged parts of machine should be replaced with only original ones.
- 14) After finishing operating, always clean beveling machine from metal chips.
- 15) Always unplug machine from power supply during any work on the machine, when adjusting angles or performing any other work on the machine.
- 16) Always disconnect machine from power source before performing any

maintenance or repair activities.

- 17) Maintain machine and tools with care. Cover steel elements with thin grease layer to protect machine against rust when not in use for a longer period of time.
- 18) It is necessary to clean metal chips from machine, particularly from milling head every time the work is finished, provided that power cord is disconnected from the socket.
- 19) Each time before use, inspect machine to ensure no damage incurs and to determine that machine will operate properly and for intended purpose. Check whether any part is cracked, all parts are properly fastened and proper conditions that may affect operation of machine are kept.
- 20) Use only authorized service centre, appointed by Seller, for any mechanical and electrical repairs of the beveller.
- 21) Before each use the machine should be checked for the presence of damage and the proper and consistent use. Check whether any of the parts are broken and all the parts are fasten properly. Make sure to maintain proper conditions affecting work of the machine.
- 22) In the case that the machine falls on a hard surface, from a height, is wet or is subjected to other unfortunate events that could affect its technical state - work should be terminated immediately and the machine should be sent to service for inspection as soon as possible.



Please keep all recommendations.

5. START UP AND OPERATION

BM-20 comes in a ready-to-use state. The only operation that needs to be carried out is adjusting it to workpiece width and the bevelling angle. Precise instructions how to perform this are given below in point 5.

Plug in the machine. Both the plug and the socket must be grounded. Lift the machine and place it vertically on its horizontal slide/rollers on the edge of your workpiece. Make sure that the milling head does not touch the desired beveled edge.

You can now turn the machine on by pressing main switch (500.04.06) to position "I". To switch machine off, press switch (500.04.06) to position "O". You can now start the motor pressing switch (500.04.07, button "I") what will be signaled with an amber light coming on (500.04.05). To stop the motor, press switch (500.04.07) again (button "O").

Start sliding the machine slowly to the right, until such a moment that the tool starts to cut steel; but remember - the direction of feed is marked on the spindle housing (200.01). The feed rate depends on the thickness of steel which is being bevelled and on the composition of that steel. Most common steels can be bevelled with just one pass.

It is recommended to bevel cuts above 12mm (1/2") width in 2 or 3 passes. Operator will put less strength and time while performing multipass bevelling.

If the operator attempts to mill too fast and too thick, the overload red indicator (500.04.04) will start flashing and if motor is overloaded even harder, power will be cut off. To start the machine again, move the tool away from bevelled edge, then press button "O" switch (500.04.07), and after few seconds you can start the machine again by pressing button "I" (switch 500.04.07).

Operator is permitted to use the machine at the brink of the cut-off point with overload light blinking, but the temperature of the motor should not exceed 85°C (185°F). High temperatures can permanently damage the motor. BM-20 is designed to work under full load for around 1 hour, after which it should cool down for about 15 minutes. The motor will not cool down running free, but it will get even warmer.

6. BEVELLING PIPES

Special optional pipe beveling attachment (part 611) allows beveling of pipes of smaller diameters and curves; a pipe beveling attachment III-a (612) is used for bigger diameter pipes. To prepare the machine for work on pipes, take the flat guide off the machine (placed on the motor side) and replace it with the pipe attachment. When adjusting rollers, it is necessary to make sure that both rollers touch a pipe surface and to ensure a fair clearance between the guide and the pipe.

Move the housing (200.01) to its "zero width cut" position. Place the machine on the edge of the pipe in such a way that the milling tool touches the workpiece (drawing 2 & 2A). Then after slackening off the bolts, move the rollers symmetrically towards the pipe so that they rest on it. Fasten both rollers. Adjust required beveling width and angle (see point 8 – "Required angle and width of cut setting"). After following above setting procedure now it is possible to start work with the machine.

Pipe bevelling attachment	611	612
Diameter of the workpiece	150 - 310 mm 6 - 12"	258 ÷ 600 mm 10 - 24"

It is not recommended for pipes with diameter less than shown in the table.

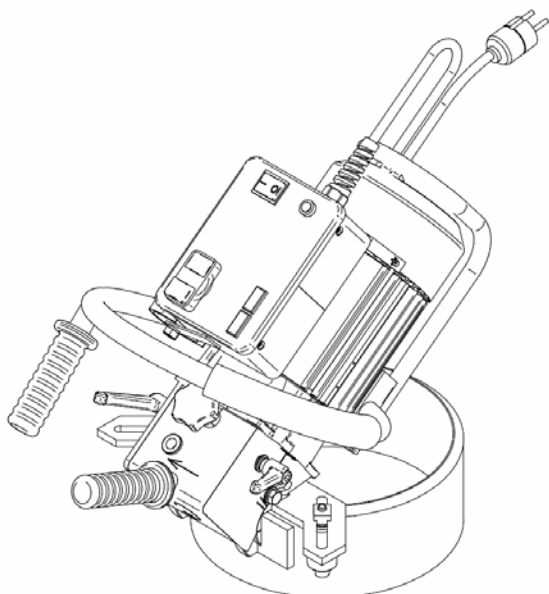

*Drawing 2
Pipe bevelling attachment (611)*

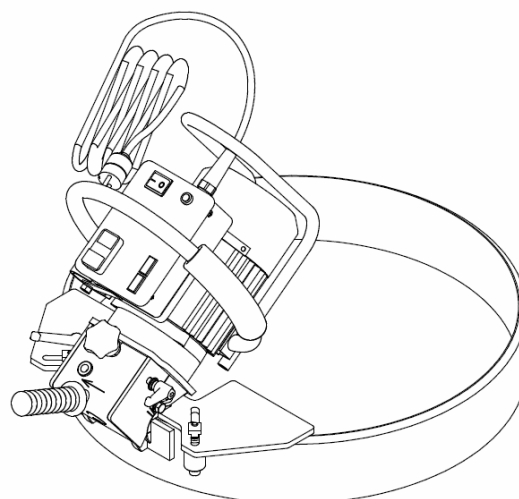

*Drawing 2A
Pipe bevelling attachment III-a (612)*

7. EDGES PLANNING WITH SET 0°

To prepare machine for planning take the 15° - 60° slide off the machine and replace it with set 0° (see drawing). After replacing, set width of cut “b” to 0 mm and continue working in the same way as in regular bevelling.

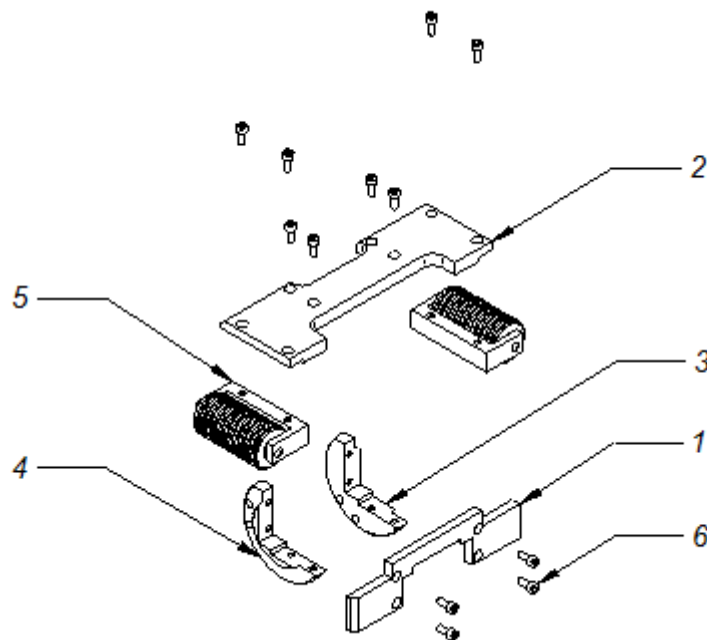

Drawing: Edges planning set 0°

	Description	Part number	Qty.
1	Guide slide I 0°	PRW-0075-32-30-00-0	1
2	Guide slide II 0°	PRW-0075-32-31-00-0	1
3	Sliders mounting I	OBS-0075-34-01-00-1	1
4	Sliders mounting II	OBS-0075-34-02-00-1	1
5	Roller set	RLK-0075-30-73-00-0	2
6	Hex. Socket bolt	SRB-000078	12

8. REQUIRED ANGLE AND WIDTH OF CUT SETTING

There are two adjustments mechanisms:

- adjusting the bevelling angle required, (β - see drawing 1),
- adjusting the machine to the thickness of steel which is being cut, (b – see drawing 1).

Before you start any adjustments make sure that the machine is unplugged from the socket.

To change bevelling angle loosen two M8 bolts (200.04) located on both sides of the milling head housing (200.01) and interlocking vertical and horizontal slides. Then change position of the two slide settings the shows the angle on the pitch marked on the side of the housing. After setting the right angle, tighten all bolts.

The width of cut can be set by turning feed bolt (105) which will change the position of the milling head. Do it by loosening two levers (203) located on the side

walls of the housing and turning the bolt (105). Then tighten levers (203). The pitch shown on the side of housing gives only approximate parameters. Precise bevelling width should be adjusted by appropriate adjustment of the housing.

9. HOW TO CHANGE INSERTS

Machine BM-20 is equipped with a double milling head, containing twelve cermetallic inserts. Recommended BM-20 inserts are only made for this machine. In case of average quality construction steel, life expectancy of those inserts is around 150 running meters (500 ft) per each side of the insert and it also depends on the operator's experience. Before you replace inserts with new ones, make sure that all four sides of each insert were used. Take the housing (200.01) off the machine. To do this, undo two levers 203. It is normally not necessary to take both milling heads (400.3) off the spindle (400.1). Using Allen wrench s3 (604) loosen screws (400.3.1) and remove inserts.

When changing inserts, make sure that all newly placed inserts in the milling head are square and that they are pushed as far back (into the holder) as possible. Before pushing new inserts into the milling head, always remove all swarfs. Drawing No 3 shows how inserts should overlap each other. Make sure that the necessary gap of about 0,2 mm is always made.

If both milling heads were removed and the replaced on the main shaft, make sure that they are installed in the right direction and that tips of each milling head are shifted relatively to each other for smoother work. If the width of cut is small, then swap all inserts according to drawing No 4, thus extending their life even longer.

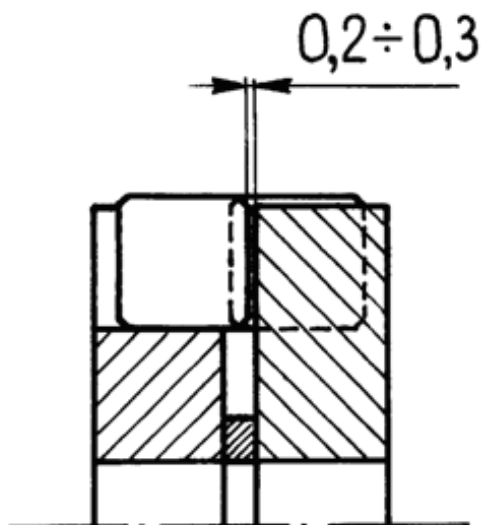

Drawing 3

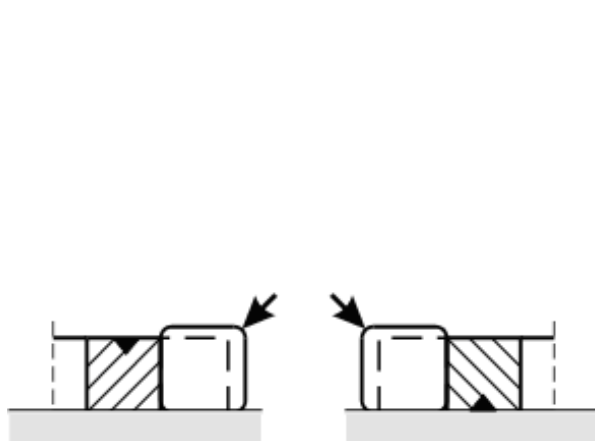

Drawing 4



Drawing 5

10. HOW TO CHANGE MILLING HEAD ASSY & MILLING HEAD ARBOR

 Replacement of milling head assembly and milling head arbor should take place only when the machine is turned off and the power cord is disconnected from the power grid!

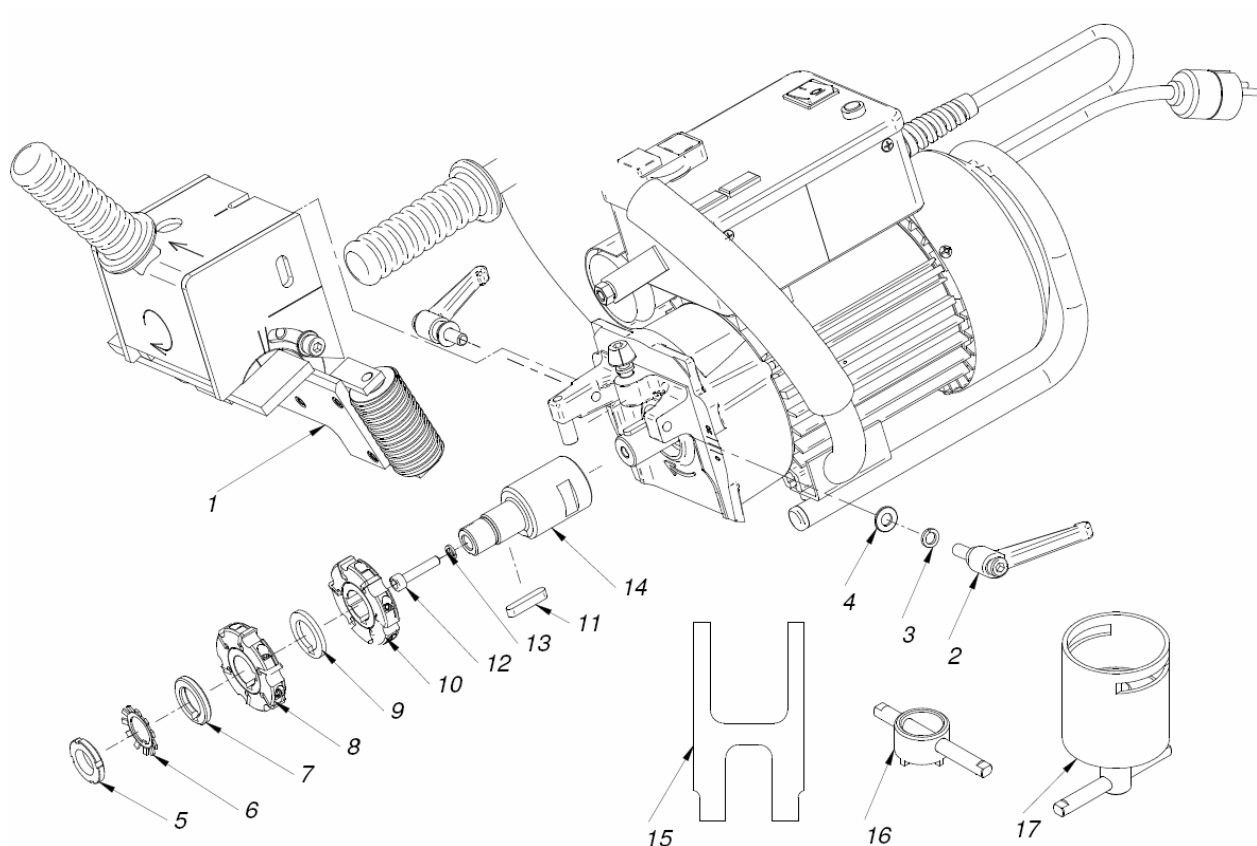

1) Milling head assembly replacement

1. Place the machine horizontally;
2. Unscrew the hand lever (2), on both sides of the machine, and dismantle guides assembly (1);
3. Lock the milling head arbor (14) with a cutter lock (15);

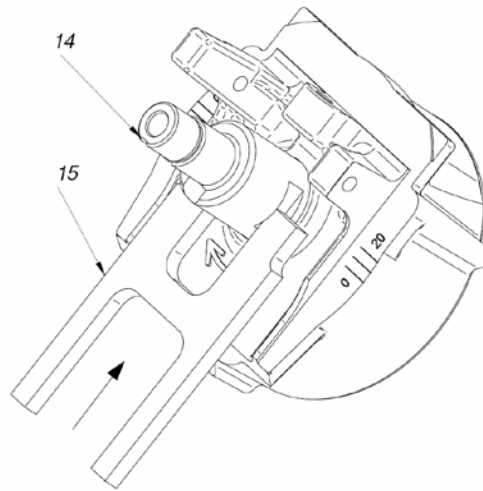

4. Bend off a tooth of a toothed lock washer (6);
5. Unscrew a nut (5), with special spanner for fastening the cutter (16);
6. Release the milling head arbor lock (15);
7. Place a cutter puller (17) on the milling head assembly in such way that cutters lock (16) can be slid into;

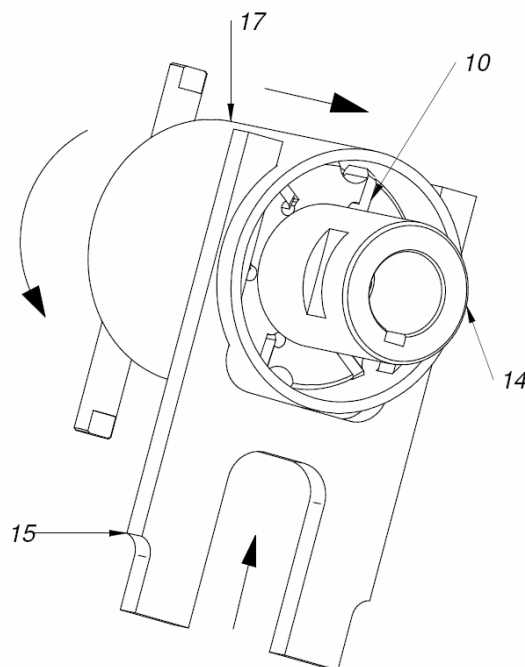

8. Take off washers (7 & 9) and the milling head body (8 & 10) by turning the bolt of the cutters puller (17) clockwise;
9. Replace milling head body (8 & 10) with new and original set;

10. **To assemble the head assembly** follow steps 3 - 8 in reverse order;
Attention: Do not invert the washers (7 & 9) – **it may damage the tool!**
11. Assemble cutting inserts by following users manual (see chapter 9 – How to change inserts);
12. Mount the guides assembly and fasten the lever (2) with washers (3 & 4).

2) Milling head arbor replacement

1. Follow steps 1 - 8 from instructions for milling head assembly replacement;
2. Lock the milling head arbor (14) with cutter lock (15);
3. Unscrew M6x10 bolt (12) and take off a spring washer of 6,1 diameter (13);
4. Replace the milling head arbor with new and original set;
5. Place milling head key (11) in the milling head arbor (14);
6. Assemble the assemblies following above steps in reverse order, analogically to the dismantling procedure.

11. HOW TO CHANGE GUIDE SET



Replacement of guide set should take place only when the machine is turned off and the power cord is disconnected from the power grid!

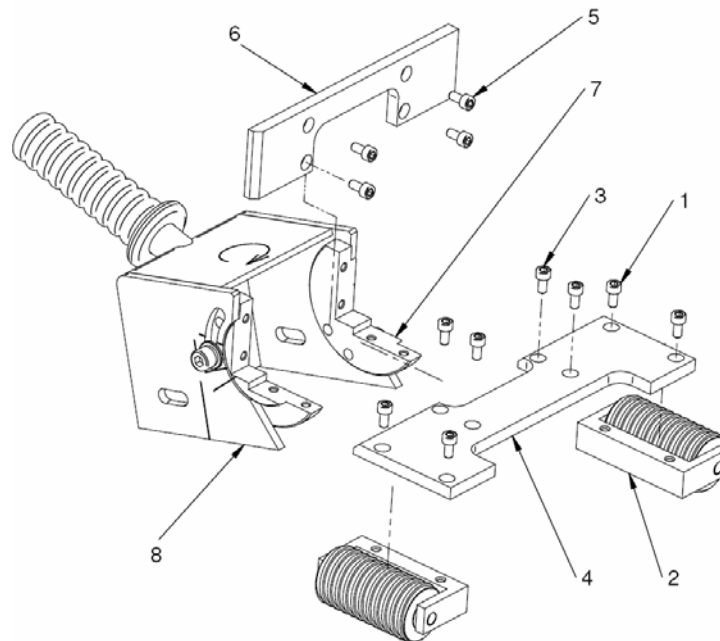

1. Place the machine horizontally,
2. Unscrew handlever placed on both sides of the assembly, dismantle the head's body (8),
3. Unscrew 4 pcs M5x10 bolts (1) and take off guiding rollers(2),
4. Unscrew 4 pcs M5x10 bolts (3) and take off the guide II (4),
5. Unscrew 4 pcs M5x10 bolts (5) and take off the guide I (6),
6. Take a brand new original set of guides and follow steps 1-5 in reverse order.

12. PARTS LIST

Item	Description	Part number	Qty.
100	Motor assembly /110V	SLN-0075-02-00-00-0	1
100	Motor assembly /240V	SLN-0075-02-00-00-1	1
100.4	Stop pin	KLK-0075-25-80-00-0	1
101	Holder (set)	UCW-0075-10-90-00-3	1
102	Cushion washer 6,1	PDK-000046	4
103	Hex. socket bolt M6x16	SRB-000106	4
104	Hex. Nut M6	NKR-000018	4
105	Feed bolt	SRB-0059-20-20-00-0	1
200	Slides set: 15°-60°	ZSP-0075-34-00-00-0	1
200.01	Spindle housing: 15°-60°	GLW-0075-26-00-00-0	1
200.02	Sliders mounting I 15°-60°	OBS-0075-34-01-00-0	1
200.03	Sliders mounting II 15°-60°	OBS-0075-34-02-00-0	1
200.04	Hex. socket bolt M8x20	SRB-000147	2
200.05	Cushion washer 8,2	PDK-000049	2
200.06	Round washer 8,4	PDK-000023	2
200.07	Guide slide I	PRW-0059-30-30-00-0	1
200.08	Hex. socket bolt M5x10	SRB-000075	8
200.09.1	Guide slide II	PRW-0075-30-70-00-1	1
200.09.5	Hex. socket bolt M5x12	SRB-000078	4
200.11	Roller set	RLK-0075-30-73-00-0	2
201	Round washer 8,4	PDK-000022	2
202	Cushion washer 8,2	PDK-000051	2
203	Handle assy M8x20	RKJ-000012	2
400.1	Milling head arbor	OBS-0059-40-10-00-0	1
400.2	Milling head key	WPS-0059-40-40-00-1	1
400.3	Milling head assy with cerment insert	ZSP-0075-43-00-00-0	1
400.3	Milling head assy w/out cerment insert	ZSP-0075-42-00-00-0	1
400.3.1	Insert screw M6x0,75x6	WKR-000027	12
400.3.2	Milling insert	PLY-000004	12
400.4	Safety washer MB-4	PDK-000070	1
400.5	Bearing nut KM-4	NKR-000049	1
400.6	Distance ring	PKD-0059-40-50-00-2	1
400.7	Cushion washer 6,1	PDK-000046	1
400.8	Hex. socket bolt M6x30	SRB-000118	1
400.9	Washer	PDK-0059-41-10-00-0	1
500.03.01	Controller cover	KRP-0075-51-90-00-2	1
500.03.02	Snap bushing LA 10	PRP-000001	1

500.03.03	Internal insulation	IZL-0075-52-30-00-0	1
500.03.04	Capacitor 80MF/110V	KND-000115	1
500.03.04	Capacitor 30NF/240V	KND-000114	1
500.03.05	Seal ring (for 110V)	PRS-000169	2
500.03.05	Seal ring (for 220V)	PRS-000226	2
500.03.06	Hex. Nut M8	NKR-000020	1
500.03.07	Spring washer 8,4	PDK-000065	1
500.03.08	Spring washer 4,3	PDK-000060	2
500.03.09	Screw M4x12	WKR-000184	2
500.03.10	Seal L=120	USZ-000004	1
500.03.11	Strain relief	DLW-000007	1
500.03.12	Strain relief nut	NKR-000040	1
500.03.13	Power cord /120V	SZN-0075-00-51-00-2	1
500.03.13	Power cord /220V	SZN-0212-10-02-00-2	1
500.03.20	Seal L=520	USZ-000004	1
500.04.01	Cover (upper)	PKR-0075-50-80-00-0	1
500.04.02	Electronic module /120V	MDL-0075-60-00-00-0	1
500.04.02	Electronic module /230V	MDL-0075-60-00-00-1	1
500.04.04	Red light indicator	LMP-000001	1
500.04.05	Amber light indicator	LMP-000002	1
500.04.06	Main switch	PNK-000013	1
500.04.07	Switch ON/OFF	PRC-000007	1
500.04.08	Cover insulation	IZL-0075-52-40-00-0	1
500.04.09	Motor ON/OFF switch nut	NKR-000050	1
500.04.10	Fuse socket	OPR-000002	1
500.04.11	Fuse 5x20	BZP-000006	1
500.05	Screw M4x10	WKR-000110	4
601	Tool box	PDL-000003	1
602	Hex. wrench. S= 6	KLC-000009	1
603	Milling head fastening tool	KLC-0059-60-40-00-0	1
604	Hex. wrench. S= 3	KLC-000012	1
605	Milling head interlock	BLD-0059-60-60-00-0	1
606	Milling head puller	SCG-0059-60-70-00-0	1

OPTIONAL EQUIPMENT			
	Description	Part number	Qty
610	Edges planning set 0°	ZSP-0075-32-00-00-1	1
611	Pipe bevelling attachment	ZSP-0075-31-00-00-0	1
612	Pipe bevelling attachment III-a	ZSP-0075-31-00-00-1	1

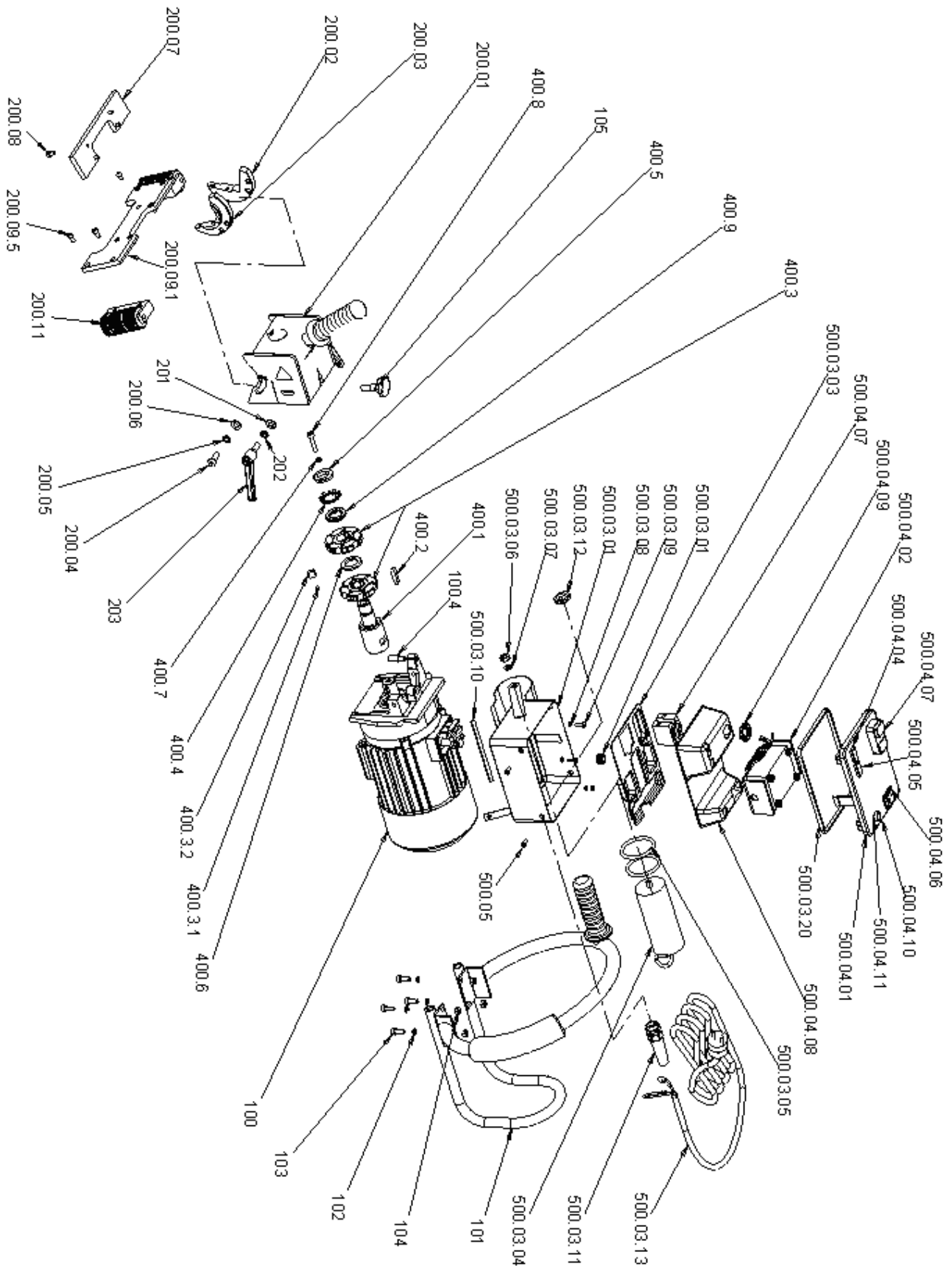

13. ELECTRIC DIAGRAM

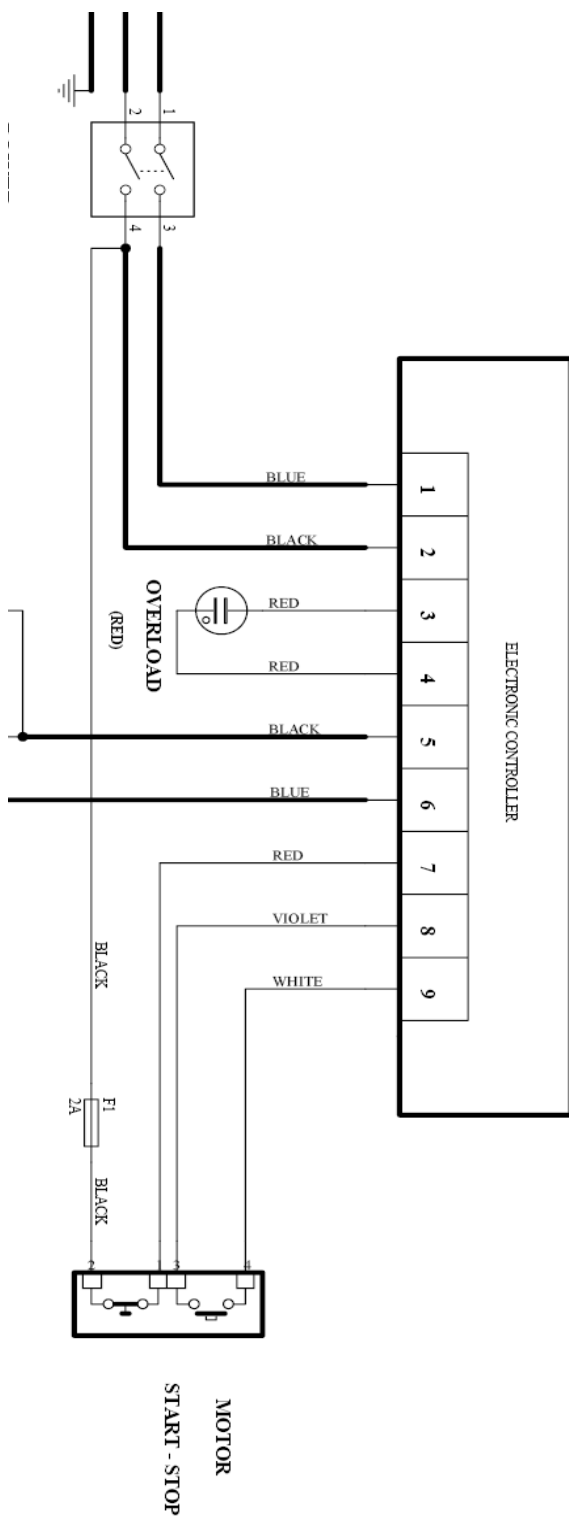

14. WARRANTY CARD

WARRANTY CARD No.....

..... in the name of
Manufacturer warrants the Bevelling Machine to be free of defects in material and
workmanship under normal use for a period of 12 months from date of sold.

This warranty does not cover cutting inserts, damage or wear arises from
misuse, accident, tempering or any other causes not related to defects in
workmanship or material.

Date of Production Serial No

Quality Control:

Date of Purchase:

Signature of Seller.....

15. CE DECLARATION OF CONFORMITY

EC Declaration of Conformity

We

***PROMOTECH Ltd.
Elewatorska street 23/1
15-620 Bialystok, Poland***

declare with full responsibility that product:

BEVELLING MACHINE BM-20

which the declaration applies to is in accordance with the following standard(s) placed below:

- **EN 50144-1**

and satisfies safety regulations of guidelines: 2006/95/EC and 2006/42/EC.

Bialystok, 2010-03-02



Chairman

6200 S Troy Circle Suite 110 Centennial, CO 80111

1-87STEELMAX FAX 303-690-9172

www.steelmax.com

16. MACHINE'S TEST CERTIFICATE

Machine control card

BM20 /120V

BM20 /220V

Serial No. _____

Date of test: _____

Electric test results:

Test	Result
Test with sinusoidal voltage of 1000 V and frequency 50 Hz	
Resistance of the protective circuit [Ω]	

The above-mentioned product meets the requirements of safe usage as prescribed in standard IEC-745

Name of tester _____

Quality Control _____