

# STEELMAX<sup>®</sup>

## Model s14

14" Dry Metal Cutting Saw

# OPERATOR'S MANUAL

E249773



LISTED  
Metal Cutting Tool  
19YZ

J1GM-DV-355

 **WARNING!**

TO REDUCE THE RISK OF INJURY, USER MUST READ AND UNDERSTAND INSTRUCTION MANUAL.



EYE PROTECTION  
REQUIRED



HEARING PROTECTION  
REQUIRED



NEVER PLACE  
FINGERS NEAR  
CUTTING AREA.  
BEWARE OF  
ROTATING  
MACHINE PARTS

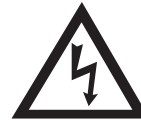

LINE VOLTAGE  
PRESENT



MODEL S14 (120V)

Serial # \_\_\_\_\_

Date of Purchase \_\_\_\_\_

# 14" Dry Metal Cutting Saw

Congratulations on your purchase of a SteelMax brand Dry Metal Cutter Saw. Please complete and mail your product registration card. Doing so will validate your machine's warranty period and ensure prompt service if needed. We sincerely thank you for selecting a product from SteelMax.

## TABLE OF CONTENTS

Limited Warranty . . . . .	2
General Safety Rules and Specific Instructions . . . . .	3-4
Specific Safety Rules and Symbols . . . . .	5-7
Functional Drawings . . . . .	8
Exploded View . . . . .	9
Parts List . . . . .	10
Assembly View . . . . .	11
Operation . . . . .	12-13
Emptying the Chip Chamber . . . . .	13
Maintenance / Changing Saw Blades . . . . .	14
Troubleshooting Checklist . . . . .	15
Specifications . . . . .	16
Accessories . . . . .	16
Warranty Card . . . . .	17-18

## LIMITED WARRANTY

Rockies Global Marketing, L.L.C. (RGM) will, within twelve (12) months from the original date of purchase, repair or replace any goods found to be defective in materials or workmanship, provided the product warranty registration card has been returned to RGM within thirty (30) days of purchase date (proof of purchase required). This warranty is void if tool is used on materials thicker than those specified under normal use, has been damaged by accident, neglect, improper service, or other causes not arising out of defects in materials or workmanship. This warranty does not apply to machines and/or components which have been altered, changed, or modified in any way, or subjected to use beyond recommended capacities and specifications. Electrical components are subject to respective manufacturers' warranties. All goods returned defective shall be returned prepaid freight to RGM, which shall be the buyer's sole and exclusive remedy for defective goods. In no event shall RGM be liable for loss or damage resulting directly or indirectly from the use of merchandise or from any other cause. RGM is not liable for any costs incurred on such goods or consequential damages. No officer, employee or agent of RGM is authorized to make oral representations of fitness or to waive any of the foregoing terms of sale and none shall be binding on RGM.

RGM RESERVES THE RIGHT TO MAKE  
IMPROVEMENTS AND MODIFICATIONS TO DESIGN WITHOUT PRIOR NOTICE.  
ROCKIES GLOBAL MARKETING, LLC.  
6200 S. TROY CIRCLE, SUITE 110, CENTENNIAL, CO 80111

# GENERAL SAFETY RULES

## **WARNING!** Read and Understand all Instructions.

Failure to follow all instructions listed below, may result in electric shock, fire and/or serious personal injury.

### **SAVE THESE INSTRUCTIONS**

#### **Work Area**

- *Keep Your Work Area Clean and Well Lit.*
- **Cluttered benches and dark areas invite accidents.**
  
- *Do not operate power tools in explosive atmospheres, such as in the presence of flammable liquids, gases, or dust. Power tools create sparks which may ignite the dust or fumes.*
  
- *Keep bystanders, children, and visitors away while operating a power tool. Distractions can cause you to lose control.*

#### **Electrical Safety**

- *Grounded tools must be plugged into an outlet properly installed and grounded in accordance with all codes and ordinances. Never remove the grounding prong or modify the plug in any way. Do not use any adapter plugs. Check with a qualified electrician if you are in doubt as to whether the outlet is properly grounded. If the tools should electrically malfunction or break down, grounding provides a low resistance path to carry electricity away from the user.*
  
- *Avoid body contact with grounded surfaces such as pipes, radiators, ranges and refrigerators. There is an increased risk of electric shock if your body is grounded.*
  
- *Don't expose power tools to rain or wet conditions. Water entering a power tool will increase the risk of electric shock.*

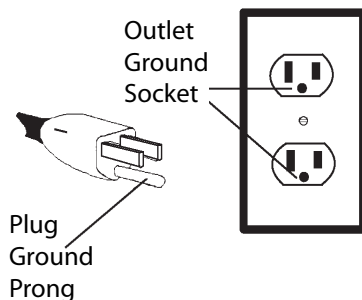

- *Do not abuse the cord. Never use the cord to carry the tools or pull the plug from an outlet. Keep cord away from heat, oil, sharp edges or moving parts. Replace damaged cords immediately. Damaged cords increase the risk of electric shock.*
  
- *When operating a power tool outside, use an outdoor extension cord marked "W-A" or "W." These cords are rated for outdoor use and reduce the risk of electric shock.*

(Note) When using an extension cord, be sure to use one heavy enough to carry the current your product will draw. An undersized cord will cause a drop in line voltage resulting in loss of power and overheating. **The recommended minimum is a 12 gauge extension cord not exceeding 50 feet.**

# GENERAL SAFETY RULES (continued)

## **Personal Safety**

- *Stay alert, watch what you are doing and use common sense when operating a power tool. Do not use tool while tired or under the influence of drugs, alcohol, or medication. A moment of inattention while operating power tools may result in serious personal injury.*
- *Dress properly. Do not wear loose clothing or jewelry. Contain long hair. Keep your hair, clothing, and gloves away from moving parts. Loose clothes, jewelry, or long hair can be caught in moving parts.*
- *Avoid accidental starting. Be sure switch is off before plugging in. Carrying tools with your finger on the switch or plugging in tools that have the switch on invites accidents.*
- *Remove adjusting keys or switches before turning the tool on. A wrench or a key that is left attached to a rotating part of the tool may result in personal injury.*
- *Do not overreach. Keep proper footing and balance at all times. Proper footing and balance enables better control of the tool in unexpected situations.*
- *Use safety equipment. Always wear eye protection. Always wear hearing protection. Dust mask, non-skid safety shoes, hard hat, or hearing protection must be used for appropriate conditions.*

## **Tool Use and Care**

- *Use machine vise to secure and support the workpiece. Drop piece or long material profiles must be supported. Holding the work by hand is unstable and may lead to loss of control. Always use machine vise.*
- *Do not force tool. Use the correct tool for your application. The correct tool will do the job better and safer at the rate for which it is designed.*
- *Do not use tool if switch does not turn it on or off. Any tool that cannot be controlled with the switch is dangerous and must be repaired.*
- *Disconnect the plug from the power source before making any adjustments, changing accessories, or storing the tool. Such preventive safety measures reduce the risk of starting the tool accidentally.*
- *Store idle tools out of reach of children and other untrained persons. Tools are dangerous in the hands of untrained users.*
- *Maintain tools with care. Keep cutting tools sharp and clean. Properly maintained tools, with sharp cutting edges are less likely to bind and are easier to control.*
- *Check for misalignment or binding of moving parts, breakage of parts, and any other condition that may affect the tool's operation. If damaged, have the tool serviced before using. Many accidents are caused by poorly maintained tools.*
- *Use only accessories that are recommended by the manufacturer for your model. Accessories that may be suitable for one tool, may become hazardous when used on another tool.*

## **SERVICE**

- *Tool service must be performed only by qualified repair personnel. Service or maintenance performed by unqualified personnel could result in a risk of injury.*
- *When servicing a tool, use only identical replacement parts. Follow instructions in the Maintenance section of this manual. Use of unauthorized parts or failure to follow Maintenance Instructions may create a risk of electric shock or injury.*

# SPECIFIC SAFETY RULES AND SYMBOLS

## WARNING!

DO NOT OPERATE MACHINE IF WARNING AND/OR INSTRUCTION LABELS ARE MISSING OR DAMAGED.  
CONTACT ROCKIES GLOBAL MARKETING FOR REPLACEMENT LABELS.

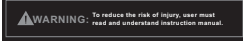
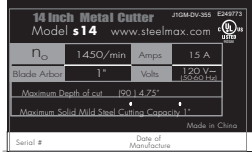

Pink lines are die cut lines and do not print.



KEEP HANDS AND BODY AWAY FROM AND TO THE SIDE OF BLADE. CONTACT WITH BLADE WILL RESULT IN SERIOUS INJURY! Use only authorized replacement blades!



To reduce the risk of injury, check lower guard. It must close instantly! Support and clamp work. Wear eye and hearing protection.



Drop piece may pose an ejection hazard! Use extra caution when cutting thin slices.



ALWAYS WEAR EYE AND HEARING PROTECTION



EYE PROTECTION REQUIRED



HEARING PROTECTION REQUIRED



NEVER PLACE FINGERS NEAR CUTTING AREA



LINE VOLTAGE PRESENT

Symbol	Description
V .....	volts
A .....	amperes
Hz .....	hertz
min .....	minutes
~ .....	alternating current
n <sub>0</sub> .....	no load speed

1. Only use SteelMax brand approved saw blades. Unauthorized blades may be dangerous!
2. Keep saw blades securely fastened. Check blade flanges for debris before installing any new blade.
3. Do not use dull or broken blades. Check blades often for condition and wear.
4. Check blade cover for proper fit to minimize the risk of flying debris.
5. Beware of ejecting chips. They become HOT both during and after cutting.
6. Always make provisions for safe handling of excess material.
7. Keep saw base free from dirt and other debris.
8. Beware of ejecting drop piece. Thinner slices pose a significant ejection hazard.

To obtain an additional copy of your manual (PN LIT401RGM), please contact RGM at:

Ph. 303.690.9146

Fx. 303.690.9172

Web [www.steelmax.com](http://www.steelmax.com)

## SPECIFIC SAFETY RULES (continued)

- DANGER! — Keep hands and body away from and to the side of the blade. Contact with blade will result in serious injury.
- WARNING! — To reduce the risk of injury, check lower guard. It must close instantly! Keep free hand away from blade at all times during operation. Support and clamp work. Wear eye and hearing protection.

### **Additional Specific Safety Rules:**

DANGER! Keep hands away from cutting area and blade. Keep your second hand on auxiliary handle, or motor housing. If both hands are holding the saw, they cannot be cut by the blade.

- Keep your body positioned to either side of the saw blade, but not in line with the saw blade. KICKBACK could cause the material to jump backwards. (See "Causes and Operator Prevention of Kickback.")
- Do not reach underneath the work. The guard can not protect you from the blade below the work.
- Check lower guard for proper closing before each use. Do not operate saw if lower guard does not move freely and close instantly. Never clamp or tie the lower guard into the open position. If saw is accidentally dropped, lower guard may be bent. Raise the lower guard and make sure it moves freely and does not touch the blade or any other part, at all angles and depths of cut.
- Check the operation and condition of the lower guard spring. If the guard and the spring are not operating properly, they must be serviced before use. Lower guard may operate sluggishly due to damaged parts, gummy deposits, or a buildup of debris.
- An unprotected, coasting blade will cause the saw to cut whatever is in its path. Be aware of the time it takes for the blade to stop after switch is released.
- NEVER hold piece being cut in your hands. It is important to support the work properly to minimize body exposure, blade binding, or loss of control.
- Contact with a "live" wire will also make exposed metal parts of the tool "live" and shock the operator.
- Always use blades with correct size and shape arbor holes. Blades that do not match the mounting hardware of the saw will run eccentrically, causing loss of control.
- Never use damaged or incorrect blade washer or bolts. The blade washer and bolt were specially designed for your saw, for optimum performance and safety of operation.
- Always clamp workpiece in vise and check security of vise bolts and position often. Vise can loosen due to vibration.

## SPECIFIC SAFETY RULES (continued)

### **CAUSES AND OPERATOR PREVENTION OF KICKBACK**

Kickback is a sudden reaction to a pinched, bound or misaligned saw blade, causing an uncontrolled workpiece to lift up and out of the saw toward the operator. When the blade is pinched or bound tightly by the kerf (saw cut) closing down, the blade stalls and the motor reaction drives the workpiece rapidly backward. If the blade becomes twisted or misaligned in the cut, the teeth at the back edge of the blade can dig into the top surface of the material causing the material to climb out of the blade and jump back toward operator. Kickback is the result of tool misuse and/or incorrect operating procedures or conditions and can be avoided by taking proper precautions as given below:

Maintain a firm grip with both hands on the saw. KICKBACK forces can be controlled by the operator, if proper precautions are taken.

When blade is binding, or when interrupting a cut for any reason, release the trigger and hold the saw motionless in the material until the blade comes to a complete stop. Never attempt to remove the workpiece from the saw or pull the material backward while the blade is in motion or KICKBACK may occur. Investigate and take corrective actions to eliminate the cause of blade binding.

When restarting a saw in the workpiece, center the saw blade in the kerf and check that saw teeth are not engaged into the material. If saw blade is binding, it may walk up or KICKBACK from the workpiece as the saw is restarted.

Support large panels to minimize the risk of blade pinching and KICKBACK. Large panels tend to sag under their own weight. Supports must be placed under the panel on both sides, near the line of cut and near the edge of the panel.

Do not use dull or damaged blade. Dull or improperly set blades produce narrow kerf causing excessive friction, blade binding and KICKBACK.

Blade depth and miter adjusting locking levers must be tight and secure before making a cut. If blade adjustment shifts while cutting, it may cause binding and KICKBACK.

# FUNCTIONAL DRAWINGS

 **Caution! Always unplug saw before changing blades, servicing or adjusting saw.**

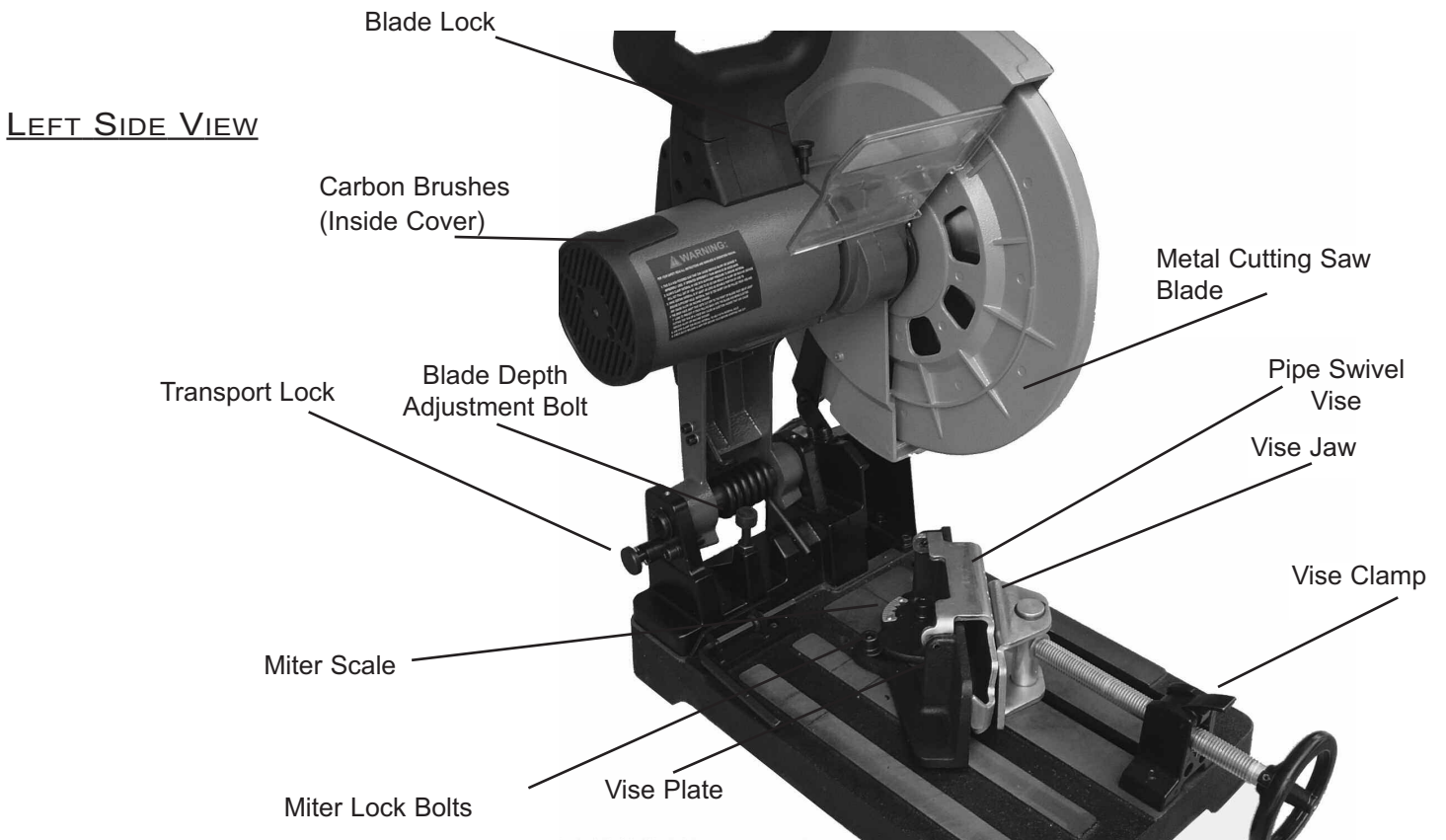
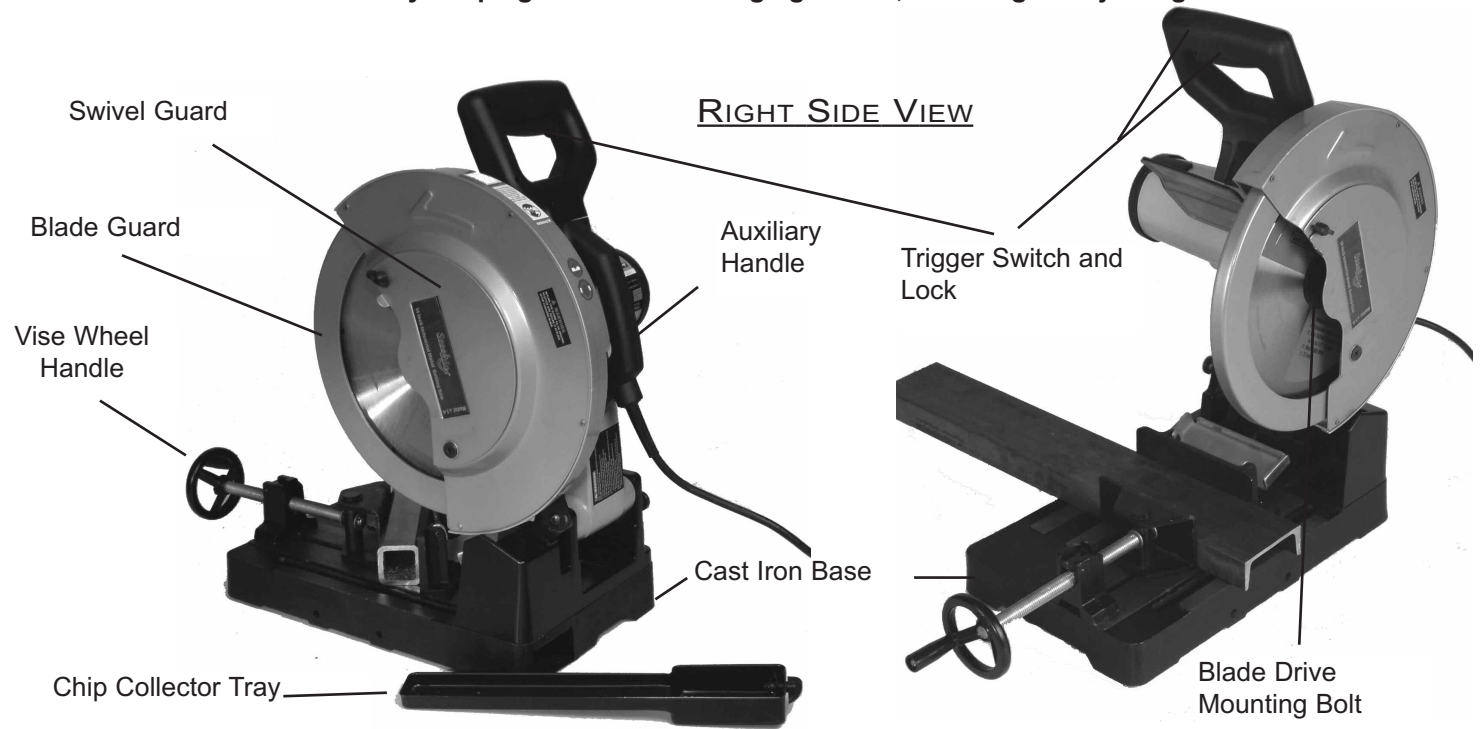

# EXPLODED VIEW

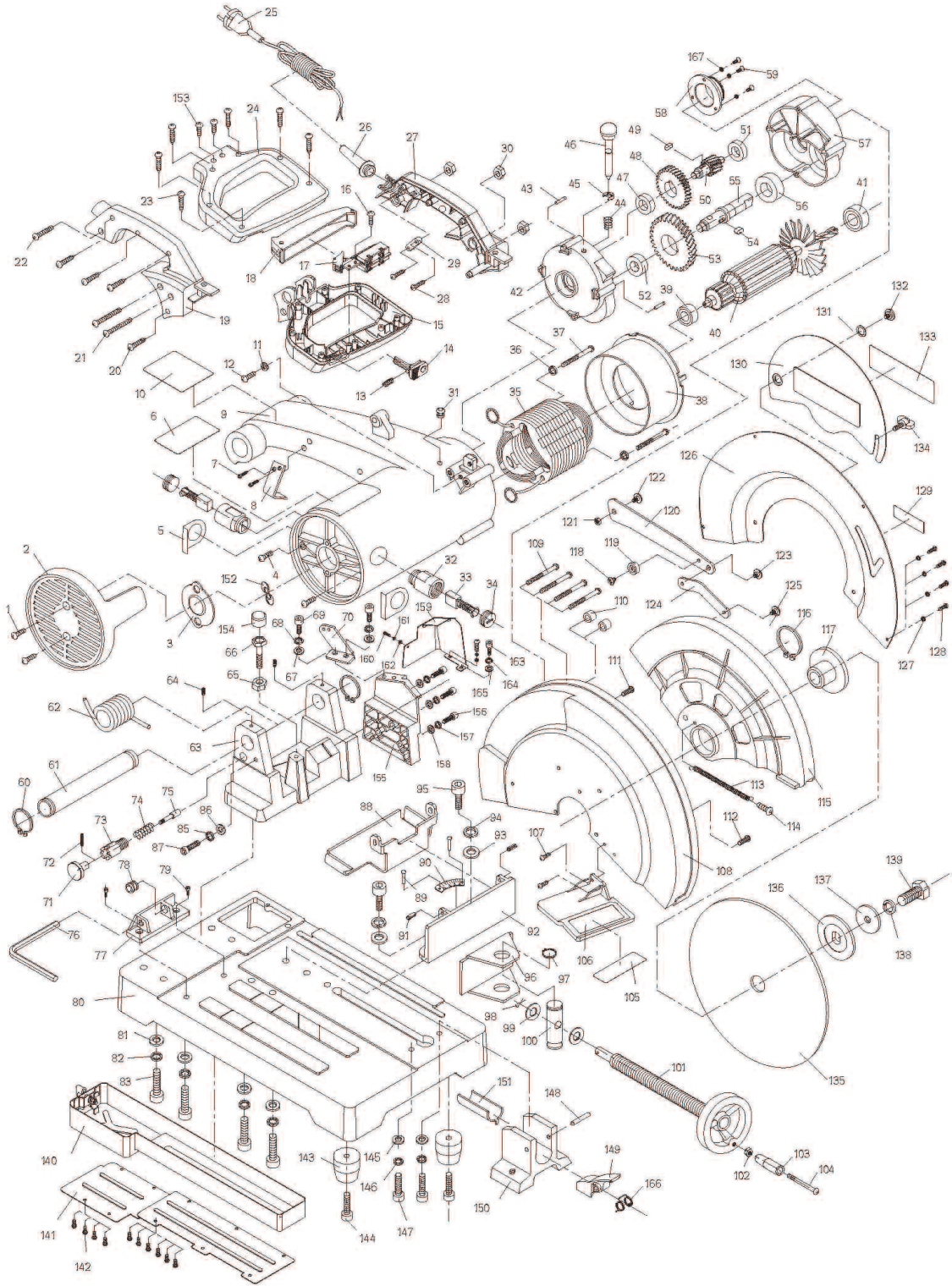

# PARTS LIST

Item	Description	Part#	Qty.	Item	Description	Part#	Qty.
1	SCREW M5X15	SMS14-1	2	84			0
2	END COVER	SMS14-2	1	85	SPRING WASHER 8	SMS14-85	1
3	BEARING CAP	SMS14-3	1	86	WASHER 8	SMS14-86	1
4	SCREW M5X10	SMS14-4	2	87	HEX BOLT M8X35	SMS14-87	1
5	PAPER PAD	SMS14-5	2	88	SWIVEL VISE	SMS14-88	1
6	NAME PLATE	SMS14-6	1	89	RIVET 3X8	SMS14-89	2
7	HEX SCREW M5X15	SMS14-7	2	90	MITER SCALE	SMS14-90	1
8	DEPTH LIMIT	SMS14-8	1	91	PIN 6X14	SMS14-91	2
9	MOTOR HOUSING	SMS14-9	1	92	VISE PLATE	SMS14-92	1
10	WARNING LABEL	SMS14-10	1	93	WASHER 10	SMS14-93	2
11	SPRING WASHER	SMS14-11	1	94	SPRING WASHER 10	SMS14-94	2
12	SCREW M5X10	SMS14-12	1	95	HEX BOLT M10X25	SMS14-95	2
13	SPRING	SMS14-13	1	96	VISE JAW	SMS14-96	1
14	THUMB SWITCH	SMS14-14	1	97	RETAINING RING 22	SMS14-97	1
15	HANDLE-BOTTOM HALF	SMS14-15	1	98	PIN 3X26	SMS14-98	1
16	SCREW ST4.2X12	SMS14-16	1	99	WASHER 12	SMS14-99	2
17	MAIN SWITCH	SMS14-17	1	100	VISE JAW AXIS	SMS14-100	1
18	SWITCH PADDLE	SMS14-18	1	101	THREAD HANDLE	SMS14-101	1
19	CARRY HANDLE-LEFT HALF	SMS14-19	1	102	NUT M6	SMS14-102	1
20	SCREW ST4.2X25	SMS14-20	1	103	WHEEL HANDLE	SMS14-103	1
21	SCREW M5X60	SMS14-21	2	104	SCREW M6X54	SMS14-104	1
22	SCREW M5X30	SMS14-22	1	105	WARNING LABEL	SMS14-105	1
23	SCREW ST4.2X19	SMS14-23	9	106	EYE PROTECTION	SMS14-106	1
24	HANDLE-TOP HALF	SMS14-24	1	107	SCREW M4X12	SMS14-107	2
25	POWER CORD	SMS14-25	1	108	SAFETY COVER	SMS14-108	1
26	CORD BOOT	SMS14-26	1	109	SCREW M5X90	SMS14-109	4
27	CARRY HANDLE-RIGHT HALF	SMS14-27	1	110	RUBBER STOPPER	SMS14-110	2
28	SCREW ST4.2X15	SMS14-28	2	111	SCREW M5X12	SMS14-111	1
29	CORD CLAMP	SMS14-29	1	112	SCREW M4X10	SMS14-112	1
30	NUT M5	SMS14-30	3	113	LOAD SPRING	SMS14-113	1
31	RUBBER SLEEVE	SMS14-31	1	114	SCREW M4X10	SMS14-114	1
32	BRUSH HOLDER	SMS14-32	2	115	LOWER RETRACTING GUARD	SMS14-115	1
33	CARBON BRUSH	SMS14-33	2	116	RETAINING RING 42	SMS14-116	1
34	BRUSH CAP	SMS14-34	2	117	INNER FLANGE	SMS14-117	1
35	STATOR	SMS14-35	1	118	SCREW 2	SMS14-118	1
36	SPRING WASHER 5	SMS14-36	2	119	GUARD RETRACTING ROLLER	SMS14-119	1
37	SCREW M5X80	SMS14-37	2	120	LEVER 1	SMS14-120	1
38	WIND BAFFLE	SMS14-38	1	121	NUT M5	SMS14-121	1
39	BEARING	SMS14-39	1	122	SCREW 4	SMS14-122	1
40	ARMATURE	SMS14-40	1	123	SCREW	SMS14-123	1
41	BEARING	SMS14-41	1	124	LEVER 2	SMS14-124	1
42	GEAR HOUSING-LEFT	SMS14-42	1	125	SCREW 3	SMS14-125	1
43	PIN A4X18	SMS14-43	2	126	STEEL COVER	SMS14-126	1
44	SPRING	SMS14-44	1	127	SPRING WASHER 4	SMS14-127	4
45	RETAINING RING 8	SMS14-45	1	128	SCREW M4X10	SMS14-128	4
46	SPINDLE LOCK	SMS14-46	1	129	WARNING LABEL	SMS14-129	1
47	BEARING (6000)	SMS14-47	1	130	SWIVEL GUARD	SMS14-130	1
48	SMALLER GEAR	SMS14-48	1	131	WASHER	SMS14-131	1
49	KEY 5X12	SMS14-49	1	132	SCREW	SMS14-132	1
50	GEAR SHAFT	SMS14-50	1	133	LOGO LABEL	SMS14-133	1
51	BEARING (6200)	SMS14-51	1	134	WING NUT	SMS14-134	1
52	BEARING (6001)	SMS14-52	1	135	SAW BLADE	RGMBL014	1
53	BIGGER GEAR	SMS14-53	1	136	OUTER FLANGE	SMS14-136	1
54	KEY 6X12	SMS14-54	1	137	WASHER	SMS14-137	1
55	OUTPUT SHAFT	SMS14-55	1	138	SPRING WASHER 10	SMS14-138	1
56	BEARING (6204)	SMS14-56	1	139	HEX BOLT M10X25	SMS14-139	1
57	GEAR HOUSING-RIGHT	SMS14-57	1	140	CHIP BOX	SMS14-140	1
58	BEARING CAP	SMS14-58	1	141	CHIP BOX SEAT	SMS14-141	1
59	SCREW M4X12	SMS14-59	3	142	SCREW M4X10	SMS14-142	10
60	RETAINING RING 14	SMS14-60	2	143	RUBBER FOOT	SMS14-143	2
61	ARM AXIS	SMS14-61	1	144	HEX BOLT M8X35	SMS14-144	2
62	LOAD SPRING	SMS14-62	1	145	WASHER 8	SMS14-145	2
63	PIVOTING ARM BASE	SMS14-63	1	146	SPRING WASHER 8	SMS14-146	2
64	SCREW M5X13	SMS14-64	2	147	HEX BOLT M8X30	SMS14-147	2
65	NUT M8	SMS14-65	1	148	PIN	SMS14-148	1
66	BOLT M8X50	SMS14-66	1	149	CLAMP	SMS14-149	1
67	WASHER 6	SMS14-67	2	150	SUPPORT	SMS14-150	1
68	SPRING WASHER 6	SMS14-68	2	151	PAD	SMS14-151	1
69	HEX SCREW M6X20	SMS14-69	2	152	BEARING SPRING CLIP 14	SMS14-152	1
70	RETRACTING LEVEL SEAT	SMS14-70	1	153	SCREW ST4.2X15	SMS14-153	2
71	TRANSPORT LOCK	SMS14-71	1	154	BOLT CAP	SMS14-154	1
72	PIN 3X18	SMS14-72	1	155	SMALL BASE	SMS14-155	1
73	LOCK SEAT	SMS14-73	1	156	HEX BOLT M6X30	SMS14-156	3
74	SPRING	SMS14-74	1	157	WASHER 6	SMS14-157	3
75	PIN	SMS14-75	1	158	SPRING WASHER 6	SMS14-158	3
76	HEX WRENCH 8MM	SMS14-76	1	159	STEEL COVER	SMS14-159	1
77	WRENCH SEAT	SMS14-77	1	160	SCREW M5X15	SMS14-160	1
78	RETAINING RUBBER	SMS14-78	1	161	WASHER 5	SMS14-161	1
79	SCREW M5X15	SMS14-79	2	162	SPRING WASHER 5	SMS14-162	1
80	SAW BASE	SMS14-80	1	163	HEX BOLT M6X18	SMS14-163	2
81	WASHER 10	SMS14-81	4	164	SPRING WASHER 6	SMS14-164	2
82	SPRING WASHER 10	SMS14-81	4	165	WASHER 6	SMS14-165	2
83	HEX BOLT M10X30	SMS14-83	4	166	LOAD SPRING CLAMP	SMS14-166	1
				167	SPRING WASHER	SMS14-167	3

# ASSEMBLY

Your SteelMax® brand saw is shipped complete and protected inside its shipping box.. Remove all contents from the box and inspect to ensure no damage was incurred during shipping. Your S14 Metal Cutter package should also include the following:

DESCRIPTION	PART #	QTY
OPERATOR'S MANUAL	LIT401RGM	1
EARPLUGS (2)	RGM80289	1
SAFETY GOGGLES	RGM80290	1
8MM WRENCH	SMS14-76	1
14" STEEL BLADE (OPTIONAL)	RGMBL014	1

## GETTING STARTED



**CAUTION!**

ALWAYS DISCONNECT THE SAW FROM POWER SOURCE BEFORE MAKING ADJUSTMENTS.

Refer to the "Functional Description" on page 8 and "Exploded View" drawing on page 10. If required, install an authorized metal cutting saw blade by first loosening wingnut (item 134) and rotating the swivel guard (item 130) up and out of the way. Then loosening the 8mm blade hex bolt and remove the outer blade flange and washer. Verify the correct seat of blade onto the inner blade flange lip. Always check blade installation for proper direction of rotation. From the front of saw, blade travels downward. Improper mounting will cause blade wobble and a possible hazardous condition. Reinstall blade bolt and flanges. Position Swivel guard and secure with thumb screw (item# 134).

## ADJUSTING THE VISE

The vise has two positions for optimal cutting and a quick release swivel vise (item 88) for use with pipe, tubing and round profiles. Always use the vise in the most forward position that will completely cut through the material. Smaller profiles can lift out of the vise more easily when the vise is in the rear most position. Larger material requires the vise be moved to the rear position. To move the vise, proceed as follows:

Loosen the vise hex bolts and using the supplied 8mm hex wrench. Move the vise to the desired position and reinstall.

The thread vise wheel handle and movable vise jaw should be positioned to tightly grip material to be cut.

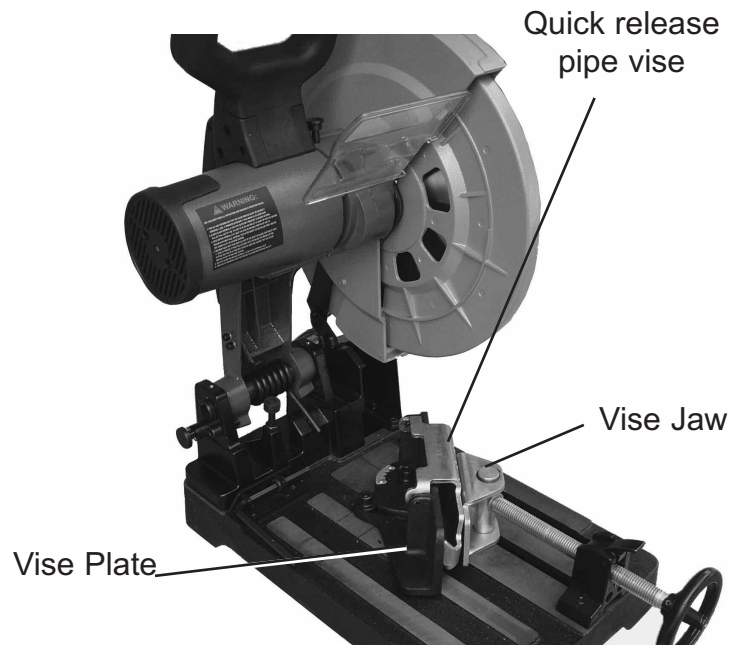

# OPERATION

## WHAT YOU SHOULD KNOW BEFORE SAWING

### **WARNING!**

NEVER START THE SAW WITH CUTTING EDGE OF SAW BLADE CONTACTING WORK SURFACE. DO NOT RETRACT BLADE GUARD (ITEM# 115) MANUALLY. GUARD RETRACTS AUTOMATICALLY.

ALWAYS CHECK BLADE DOWN-STOP BOLT, LOCK NUT AND BOLT CAP (ITEM # 65,66, 154) FOR CORRECT POSITIONING AND WEAR BEFORE FIRST USE AND AFTER EACH BLADE CHANGE. FAILURE TO DO SO COULD RESULT IN PERSONAL INJURY DUE TO BLADE CONTACT WITH SAW BASE OR CHIP BOX.

1. After installation of saw blade or before first use, adjust down-stop bolt so that blade does not contact chip tray bottom when blade is in the full down position.

## WHAT YOU SHOULD KNOW WHILE SAWING

1. Select the correct saw blade appropriate to the material being cut. (mild steel, stainless steel or aluminum)
2. The material surface should be clean and level, free from rust, dirt, scale, and other debris.
3. Material may become heat treated if flame cut. Always avoid cutting near these areas whenever possible.
4. Adjust the vise plate to the desired miter angle by loosening the left and right Miter Lock bolts (item# 95). Refer to "Exploded View".
5. When cutting smaller profiles, vise plate may be moved forward to aid in cutting quality and to minimize pull-out from the vise. Miter can be set by observing index marks printed on vise bracket.
6. Connect machine to power source.
7. Firmly grasp guide handle and trigger handle switch (item# 14, 15 and 24).
8. Position material in the saw vise and align cutting line with blade. Adjust the front and rear vise plates as necessary to firmly hold material in the desired position.
9. When ready, start saw motor by activating trigger switch (item# 17).
10. Slowly approach material edge and gently apply pressure until saw blade has established a cutting groove in the material.
11. Apply smooth, constant pressure without over-loading saw motor.

### **WARNING!**

IF SAW MOTOR SHOULD STALL OR STOP BEFORE A COMPLETE CUT IS MADE ALWAYS REMOVE BLADE FROM MATERIAL BEFORE ATTEMPTING TO RESTART MOTOR. FAILURE TO DO SO COULD RESULT IN PERSONAL INJURY.

## AFTER COMPLETING THE CUT

1. After the cut, release trigger switch to the "OFF" position.
2. When saw motor completely stops, clear both drop piece and material from vise.

## OPERATION (continued)

FOR BEST PERFORMANCE, EMPTY THE CHIP COLLECTOR BOX OFTEN.

### EMPTYING THE CHIP COLLECTOR BOX

#### WARNING!

ALWAYS DISCONNECT THE SAW FROM POWER SOURCE BEFORE CHANGING BLADES, CLEARING CHIPS OR MAKING ADJUSTMENTS.

1. Turn the Chip Collector Box retaining thumbscrew (see below).
2. Remove chip collector box from the back of saw.
3. Empty chip collector completely. Clean all debris from saw body.
4. Install chip collector box in saw and fasten securely by tightening thumbscrews.

#### WARNING!

FAILURE TO INSTALL COLLECTOR BOX TOTALLY AND SECURE MAY RESULT IN UNCONTROLLED DISCHARGE OF CHIPS AND OPERATOR INJURY. ALWAYS VERIFY PROPER INSTALLATION OF CHIP BOX AND CHECK FREQUENTLY.

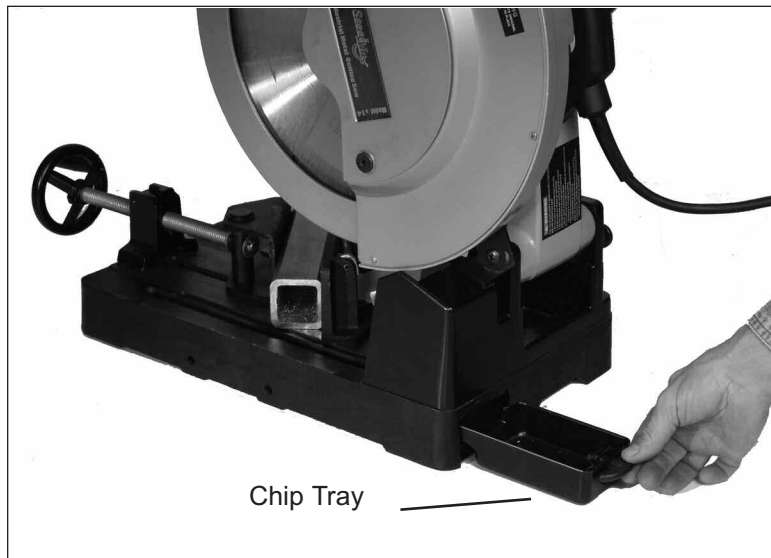

#### WARNING!

MOTOR DOWN-STOP BOLT AFFECTS HOW FAR BLADE TRAVELS INTO THE CHIP COLLECTOR BOX. AN IMPROPERLY ADJUSTED DOWN-STOP CAN HIT THE BOTTOM OF BOX, CAUSING AN EJECTION HAZARD. ALWAYS CHECK DOWN-STOP ADJUSTMENT AFTER REPLACING SAW BLADES OR SERVICING MACHINE.

## MAINTENANCE



**WARNING!**

ALWAYS DISCONNECT THE SAW FROM POWER SOURCE BEFORE CHANGING BLADES, CLEARING CHIPS OR MAKING ADJUSTMENTS.

### CHANGING SAW BLADES

Refer to the diagram to the right.

1. Place saw on a level, secure surface.
2. Move the swivel guard (item #130) by loosening the thumb screw (item #134) and rotating it to expose the blade retaining bolt.
3. Engage spindle lock (item# 46).
4. Using supplied hex wrench, loosen and remove the blade drive mounting bolt, washer and outer blade drive flange (items# 136-139).
5. Move the blade guard up and out of the way (item # 115).
6. Remove saw blade. (item 135)
7. Thoroughly clean inner and outer blade drive flanges and blade mounting surface before installing new blade.
8. Verify that blade rotation is correct.
9. Reverse process to install new blade.

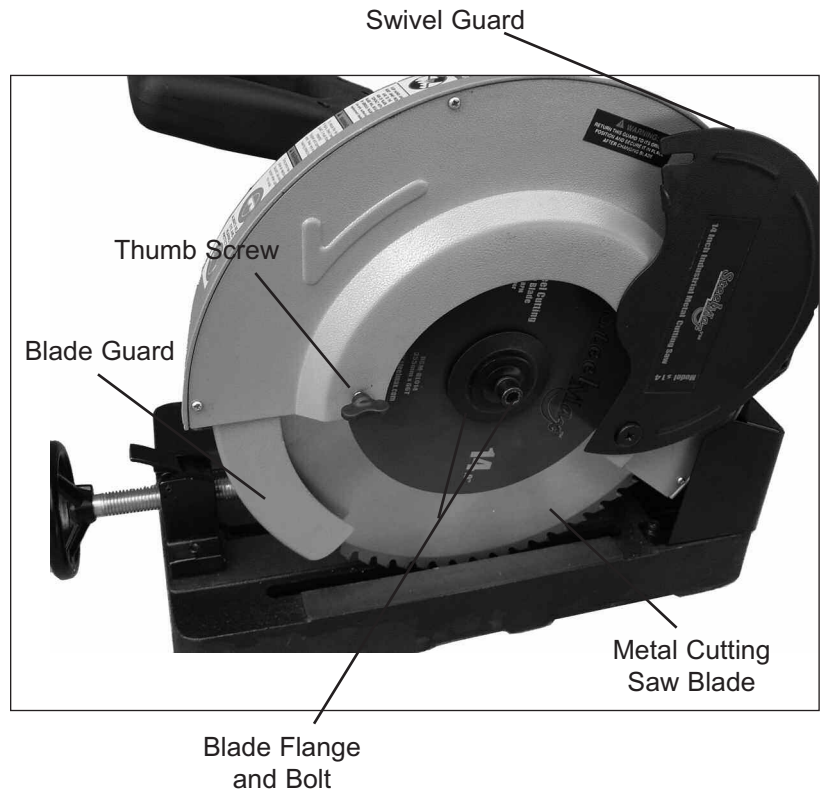

### REPLACING MOTOR BRUSHES

Refer to the diagram to the right.

1. Place saw on level, secure surface.
2. Tip saw on its right side (blade side down).
3. Remove two (2) motor end cover screws and remove the cover and motor bearing spring washer.
4. Remove the two brush caps and slide brushes out. Caution! Do not rotate brushes if re-installing. Note exact position when re-installing brushes.
3. If the carbon rod is less than 6mm or if there are signs of burning or other wear, replace the brushes.
4. Reverse the process to re-assemble saw.

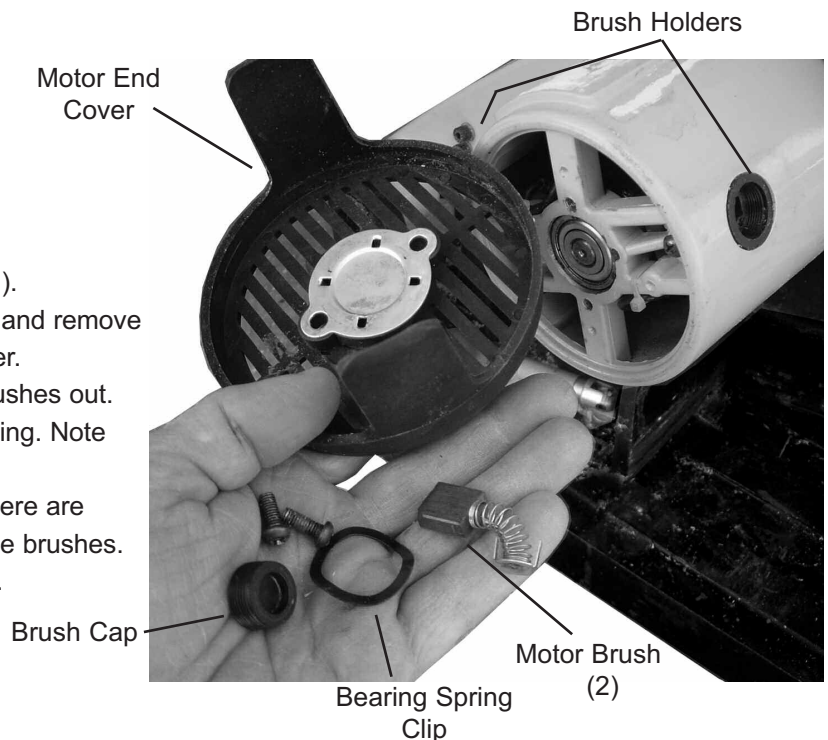

# TROUBLESHOOTING CHECKLIST

## s14 14" METAL CUTTER



ALWAYS DISCONNECT THE SAW FROM POWER SOURCE BEFORE TROUBLESHOOTING.

1. Machine will not turn on
  - Inspect power cord for damage. Check continuity. Replace if needed. (PN SMS14-25)
  - Inspect brushes for excessive wear. Replace if needed. (PN SMS14-33) (2)
  - Do not exceed 30 minutes run time without cool down of saw.
  - Check trigger switch for continuity. Replace if needed. (PN SMS14-17)
2. Losing Power
  - Inspect brushes and replace if needed. (PN SMS14-33) (2)
  - Extension cord too long. Limit cord length to 50' or less.
  - Extension cord too thin. Use 12 AWG or larger.
3. Blade Guard Sticks
  - Remove guard and remove any foreign material.  
Guard must move freely. Use light grease on mating contact surfaces to aid in movement.
  - Check guard return spring for sufficient tension. Replace if spring is weak. (PN SMS14-113)
  - Check guard for distortion. Replace if distorted or damaged. (PN SMS14-115)
4. Blade Spins on Spindle
  - Check for proper tightness and installation. Inspect inner blade flange (PN SMS14-117) and outer blade flange (PN SMS14-136) for wear or damage. Replace if wear is excessive.
  - Check flange mating surfaces for flatness. Replace if excessive distortion exists.
  - Check to ensure flat washer is present between bolt head and outer blade drive flange.
5. Low Blade Life/Teeth Chipping
  - Wrong blade for the type of material.
    - RGMBL014 for mild steel up to 1" solid.
    - RGMBL014-ALM for aluminum up to 1" solid.
    - RGMBL014-SS for stainless steel up to 1/2" solid.
    - RGMBL014-TS for thin steel up to 1/4" solid.
  - Aggressive contact with blade into material. The blade must be allowed to do the work.
  - Too much vibration due to insufficient clamping, worn or bent blade, or worn parts (see "Saw Vibrates" below).
6. Saw Vibrates
  - Check blade for tightness.
  - Inspect inner blade flange (PN SMS14-117) and outer blade drive flange (PN SMS14-136) for wear or damage. Replace if needed.
  - Check to ensure work is properly clamped. Both primary and cut-off piece can cause vibration.
  - Check miter lock for tightness. (PN SMS14-95)
  - Check blade teeth for missing carbide, bends or cracks.

# SPECIFICATIONS

## Model s14

### DIMENSIONS AND SPECIFICATIONS

Height	431mm (17")
Width	340mm (13.4")
Length	533mm (21")
Weight	68lbs.
Motor	120V - 1750W 50~60 Hz / 1450 RPM
Blade Arbor	25.4mm (1.0")
Blade Diameter	355mm (14.0")
Depth of Cut/Pipe or Angle (maximum)	120mm (4.75")
Depth of Cut/Plate or Bar Solid (maximum)	25.4mm Mild Steel (1") 25.4mm Aluminum (1") 13mm Stainless Steel (1/2")

# ACCESSORIES

### Saw Blades

Application	Part #
For cutting mild steel to 1"	RGMBL014
For cutting thin steel to 1/4"	RGMBL014 TS
For cutting aluminum to 1"	RGMBL014 ALM
For cutting stainless steel to 1/2"	RGMBL014 SS

YOUR STEELMAX DISTRIBUTOR

6200 S. Troy Circle, Suite 110  
Centennial, CO 80111

Phone 303.690.9146 or Fax · 303.690.9172

email · sales@steelmax.com / web · steelmax.com

LIT-401RGM  
©7/06

# PRODUCT REGISTRATION AND WARRANTY CARD

Thank you for purchasing a SteelMax® product!  
Please fill out this form and return promptly so that we may register your purchase.

Model# \_\_\_\_\_ Serial # \_\_\_\_\_ Date of Purchase \_\_\_\_\_

ROCKIES GLOBAL MARKETING, L.L.C.  
6200 S. TROY CIRCLE  
STE 110  
CENTENNIAL, CO 80111  
PHONE 303.690.9146  
FAX 303.690.9172  
STEELMAX.COM

*Please detach and retain this top portion for your records.*

Mr.  Mrs.  Ms.  Miss

First Name _____		Last Name _____	
Company Name _____			
Street Address _____			
City _____		State _____	Zip _____
Phone Number _____		Fax Number _____	E-mail Address _____
May we contact you by: Mail <input type="checkbox"/> Fax <input type="checkbox"/> E-mail Address <input type="checkbox"/>			
Model _____		Serial# _____	Date of Purchase _____

Where did you purchased your SteelMax product from \_\_\_\_\_

What are the top two reasons that influenced your purchase of this SteelMax brand product?

- |   |   |                                       |
|---|---|---------------------------------------|
| Reputation <input type="checkbox"/>       | Value for price <input type="checkbox"/>        | Web site <input type="checkbox"/>     |
| Safety features <input type="checkbox"/>  | Magazine ad <input type="checkbox"/>            | Availability <input type="checkbox"/> |
| Recommendation <input type="checkbox"/>   | Reputation of retailer <input type="checkbox"/> | Other <input type="checkbox"/>        |
| Style/Appearance <input type="checkbox"/> | Quality/Durability <input type="checkbox"/>     |                                       |

In your opinion, what is the BEST industry publication you regularly read? \_\_\_\_\_

Is this: A first time purchase?  An additional unit?  A replacement unit?  For which brand? \_\_\_\_\_

Additional comments: \_\_\_\_\_

Thank You! We value your answers and input.  
 **Yes, put me on the SteelMax email list for special offers.**

*Please tape here before mailing*

---

---

---

First Class  
Postage  
Required

ROCKIES GLOBAL MARKETING, L.L.C.  
6200 S. TROY CIRCLE  
SUITE 110  
CENTENNIAL, CO 80111

ATTENTION: WARRANTY DEPARTMENT